



METAL[®]
TIME

OFFICIAL EDITION

UKRAINIAN DREAM

Tribute to Mriya AN-225
3D Metal Mechanical Model Building Kit

Assembly instructions

Інструкція зі складання

Instrukcja montażu

Istruzioni di montaggio

Montageanleitung

Instructions de montage

Instrucciones de montaje

Instruções de montagem

Інструкція по сборке

装配说明书

조립 설명서

組立説明書

تعليمات التجميع

הוראות הרבה

Windup mechanism / Turbines blades rotation
Nose cargo door opening / Removable pedestal

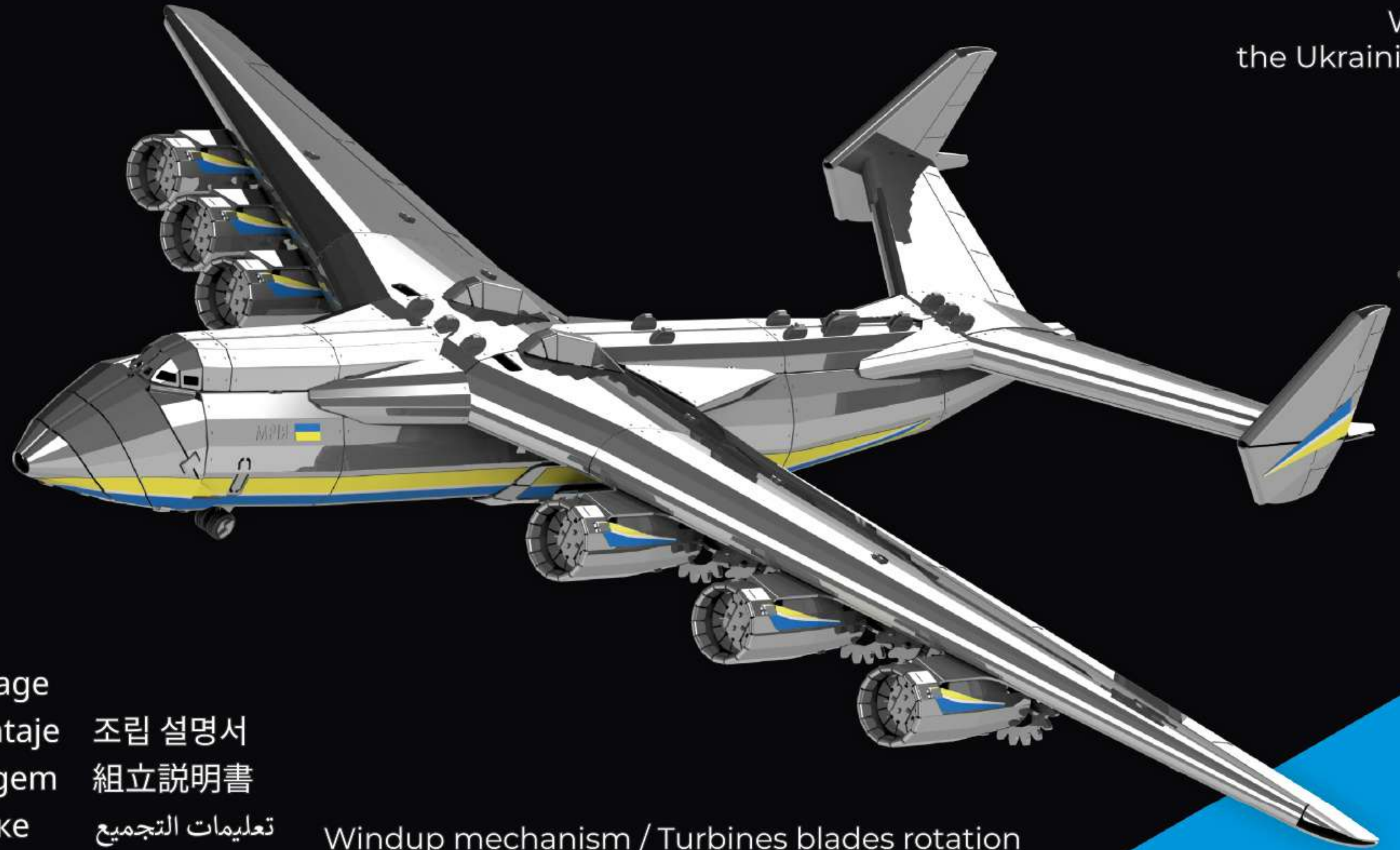

We believe
the Ukrainian Dream
is eternal!



© ANTONOV Company, 1986

AGES
14+

Collect the Best

270 PIECES

20 hours

STANDARD FIXING OF FASTENERS AND SYMBOLS

When assembling the model, don't rush, avoid pointing details at yours or anyone else's face. If one of the parts has a sharp edge, please file it down. Use pliers and additional tools to assemble the model. Each kit contains a cloth for wiping and polishing the model once it's assembled.

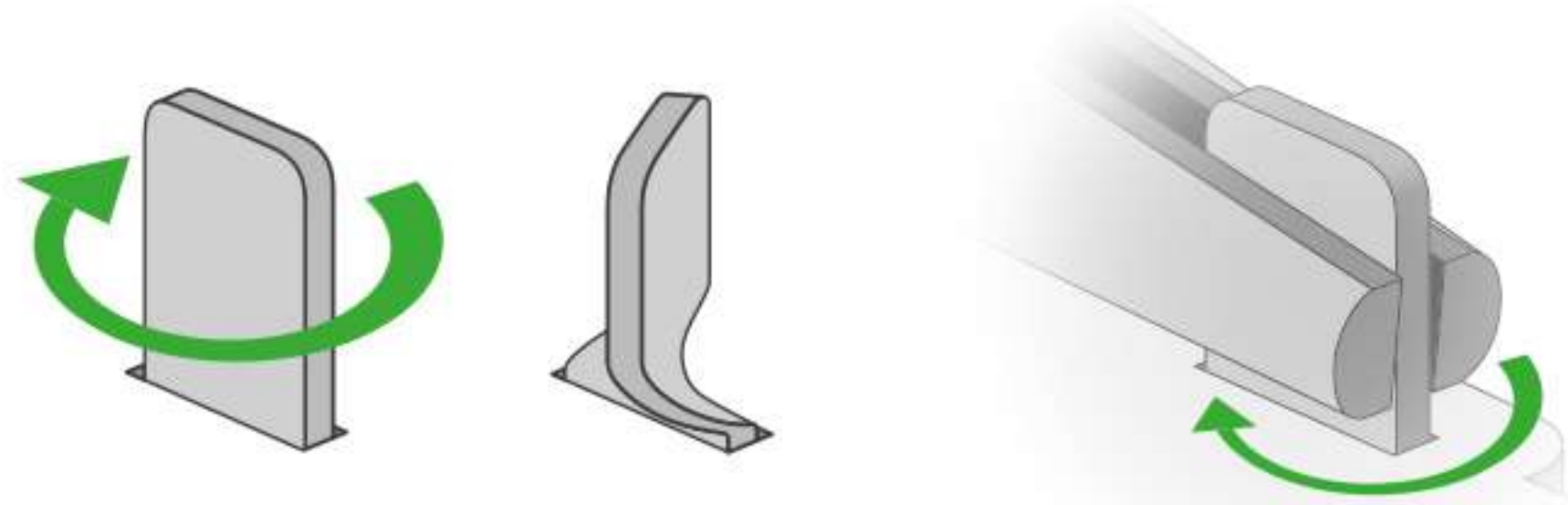

If there are no additional designations, use the standard fixing method

Use pliers to bend the fasteners



Bend the eyelet 90°

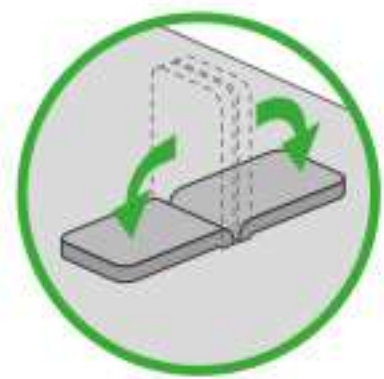

Bend the ears 90°



Twist the eyelet 45°

MODEL PARTS AND ASSEMBLY TOOLS

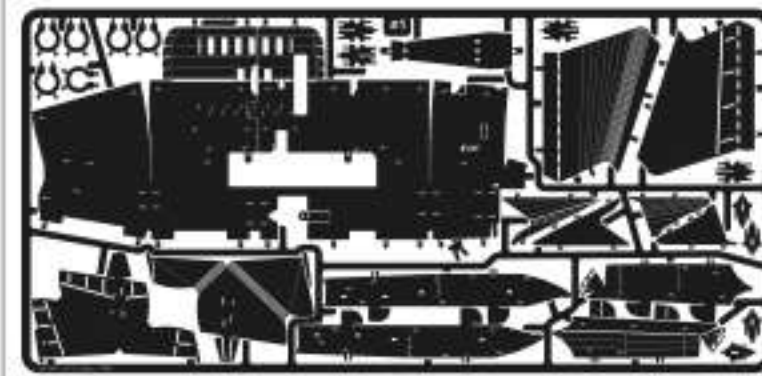

#1

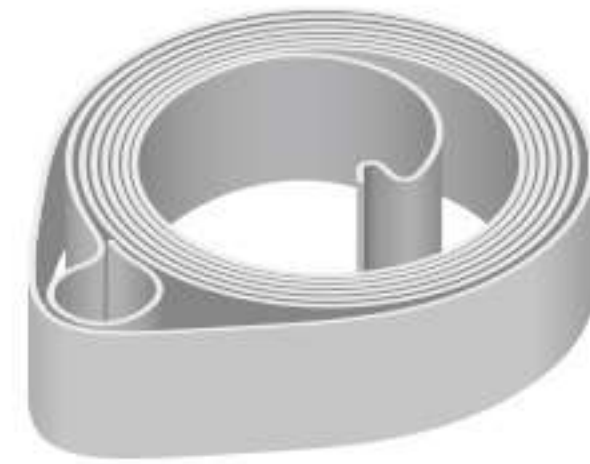

Spring

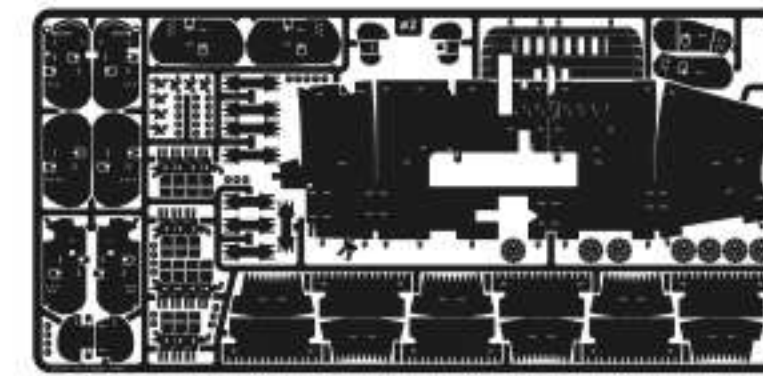

#2



G2



G3



G4

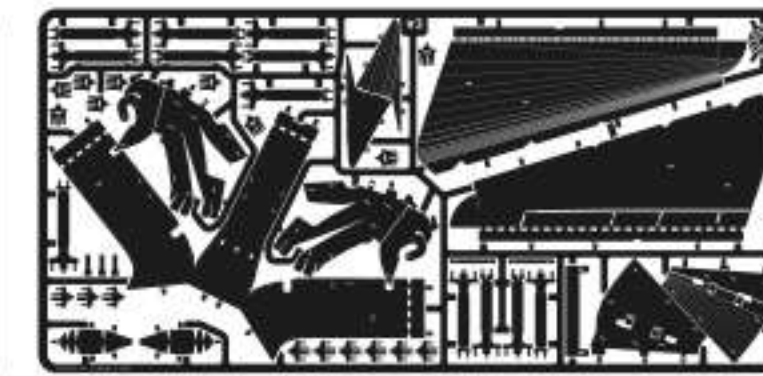

#3



G5



G6



G7

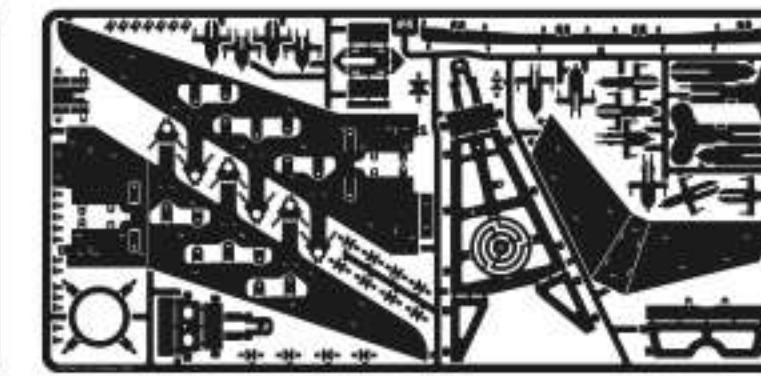

#4



G8



G9



Wheels



D1



#5

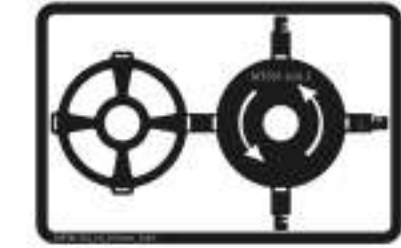

#6

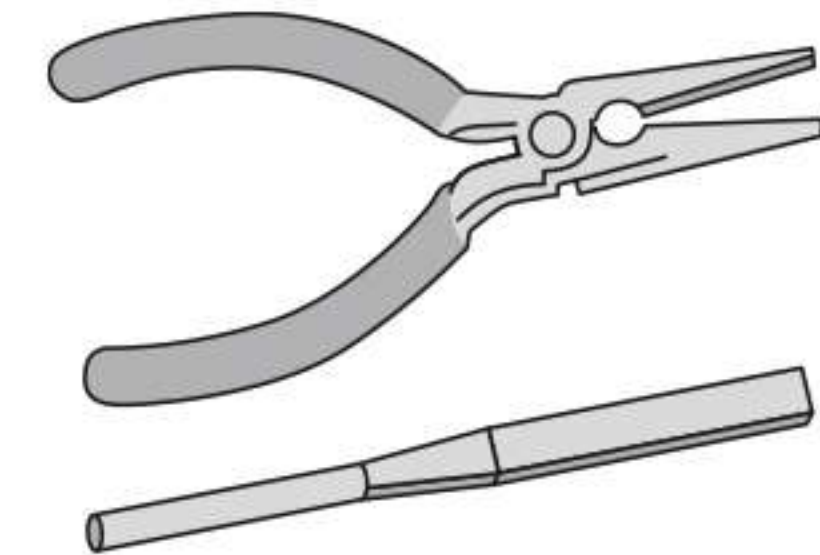

Tools

WARNING! Product contains small parts and sharp parts. Not suitable for children under 3 years of age. Please read these instructions carefully before assembly and use.

WARNING! Cut/remove the band that keeps the spring in place ONLY WITHIN the spring chamber/container. DO NOT cut the restraining band outside the assembled spring chamber, as the spring will unwind with force

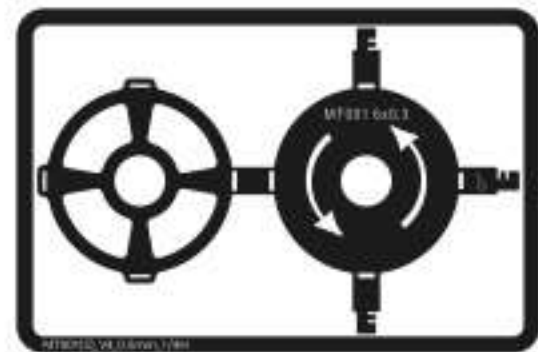

#6



Spring

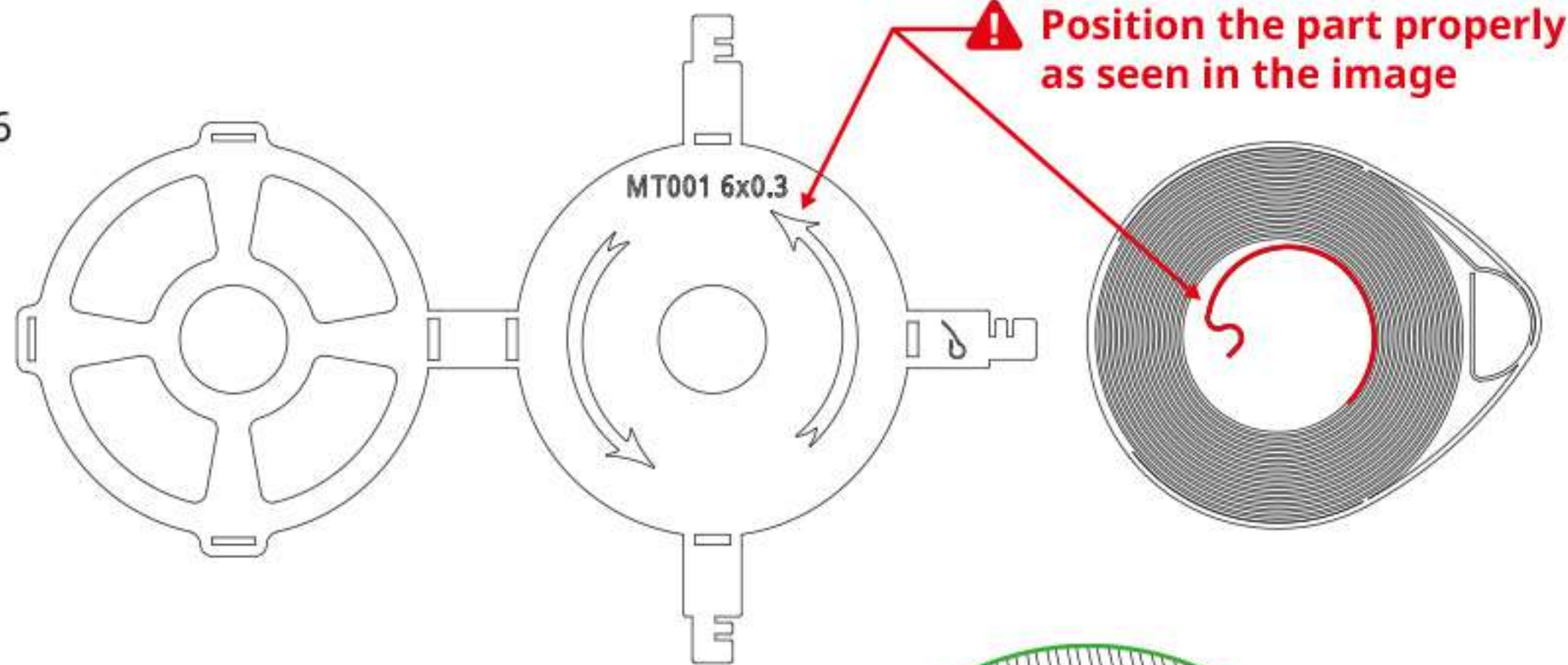
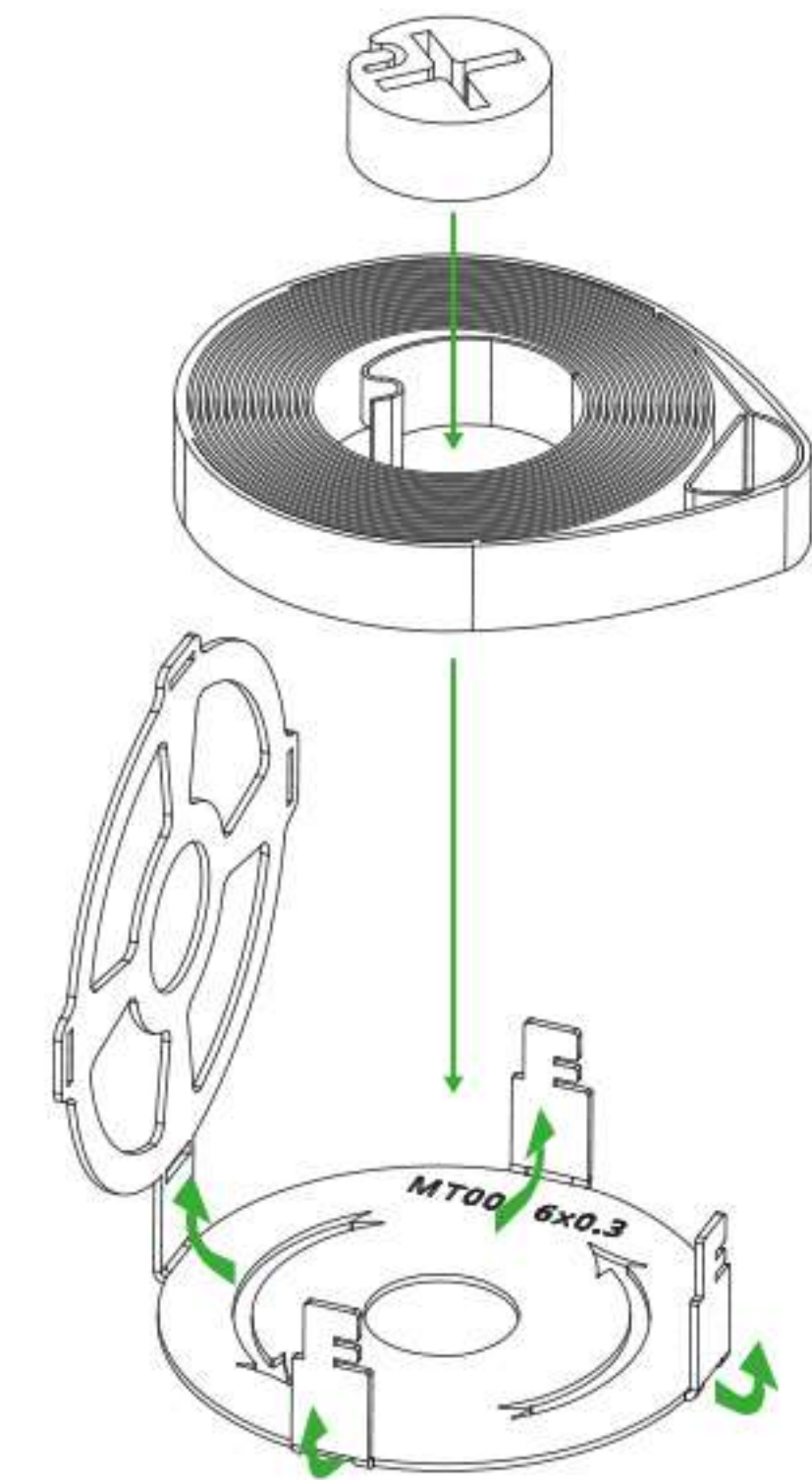

Position the part properly as seen in the image

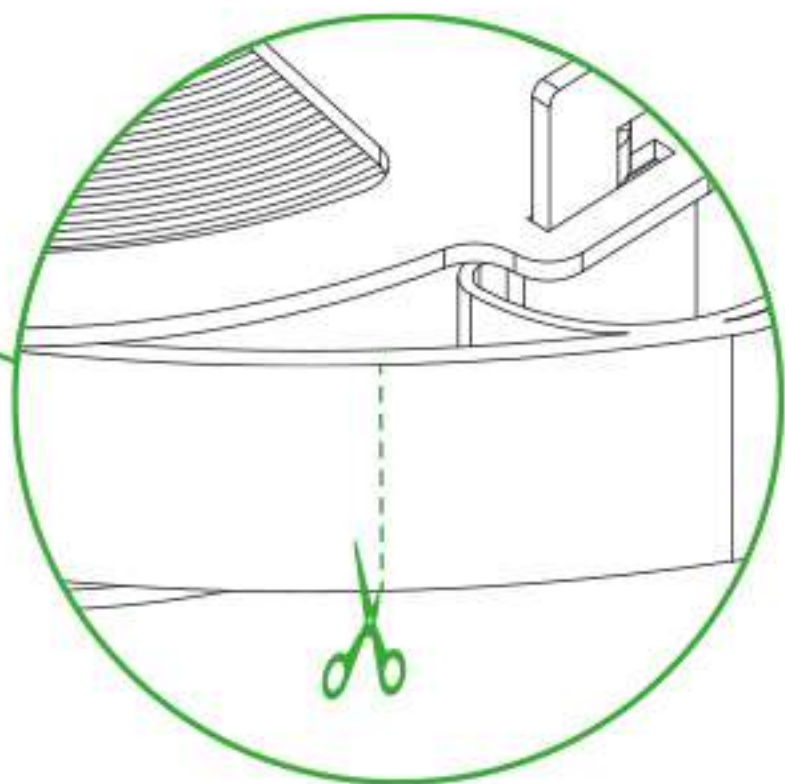
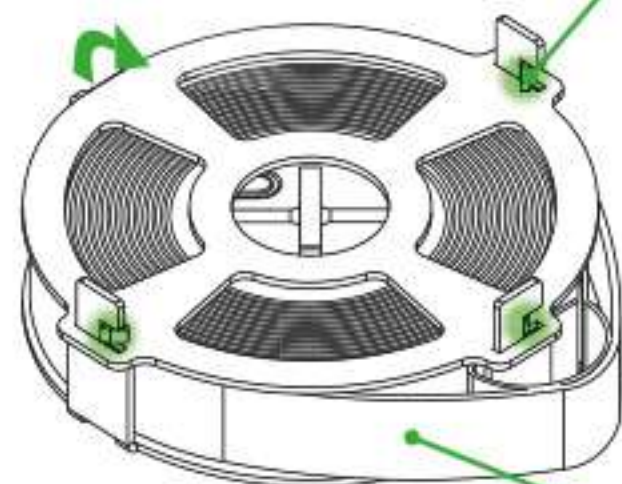
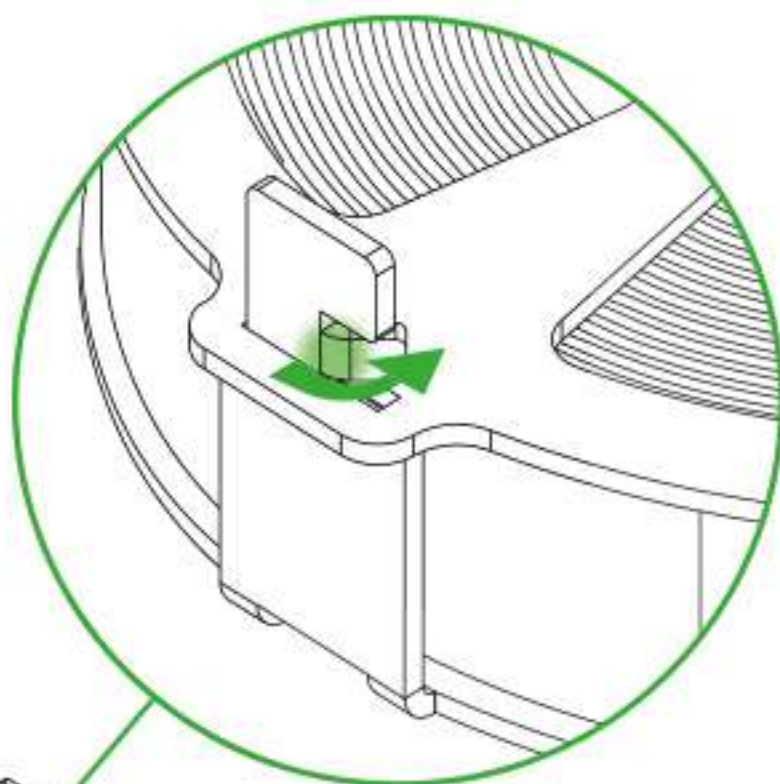

1

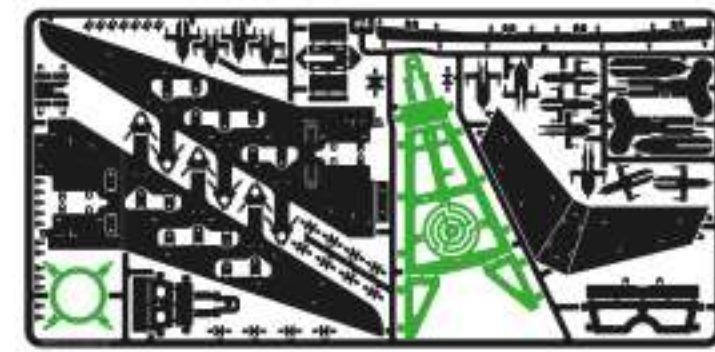

#4

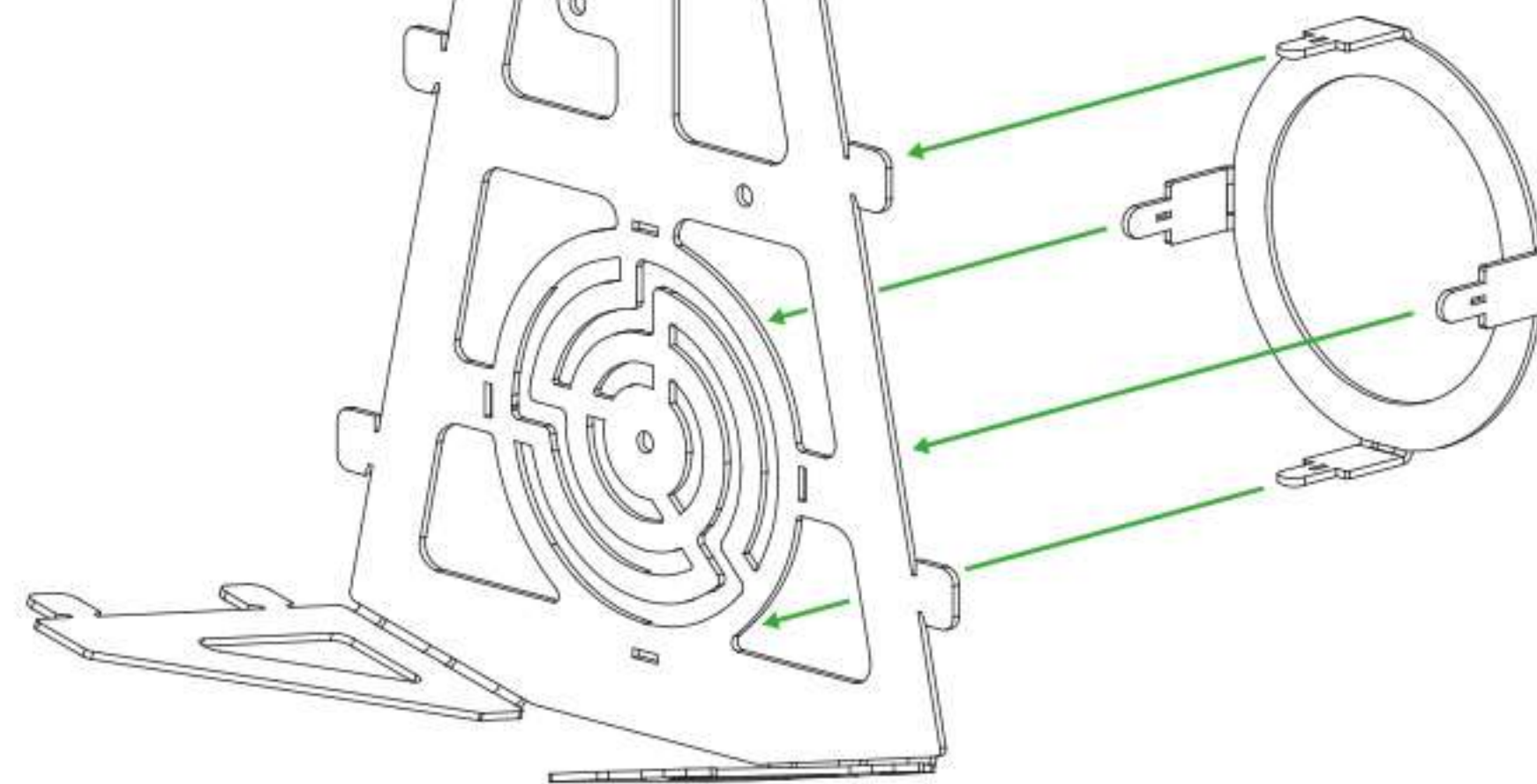
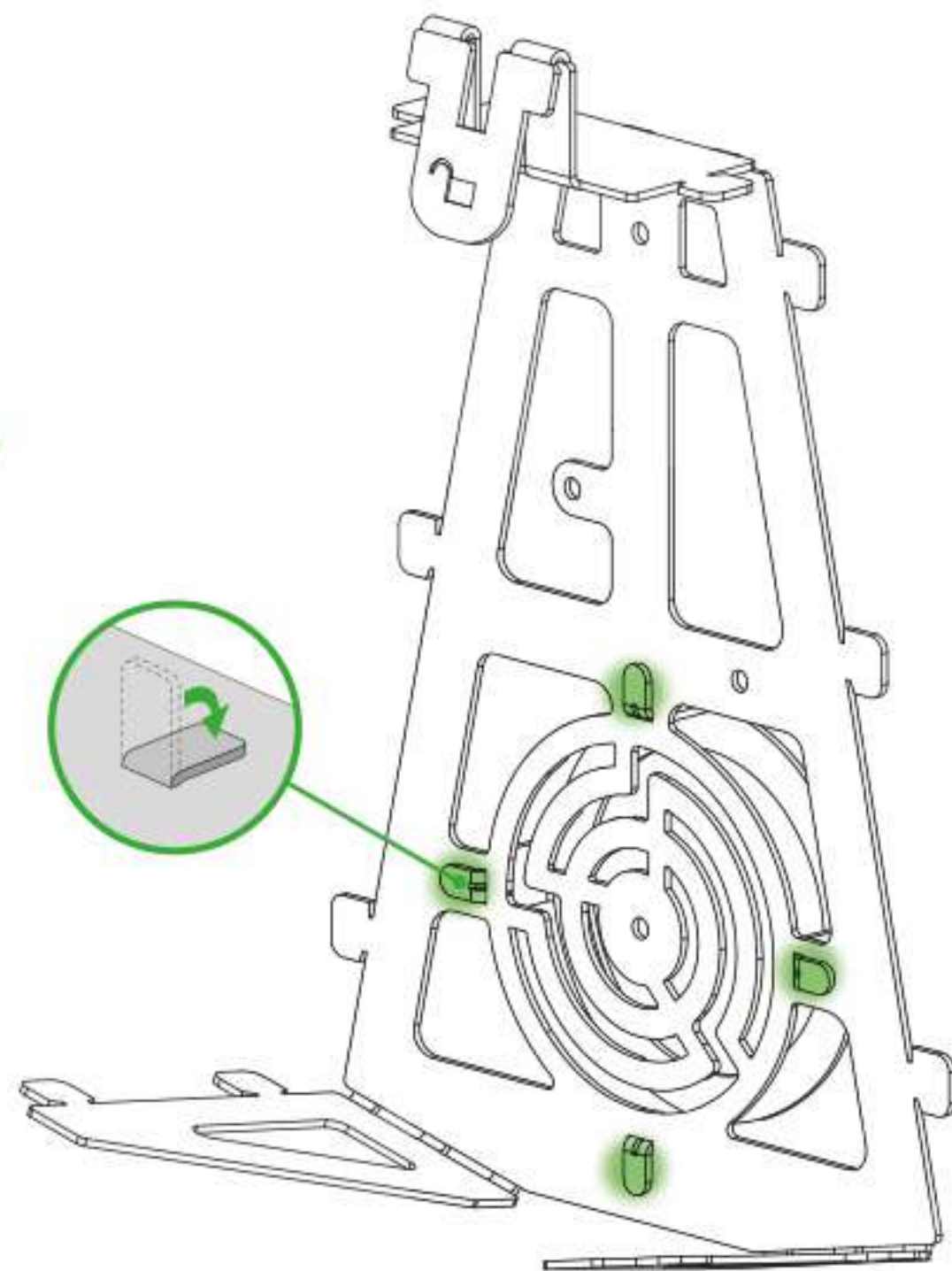
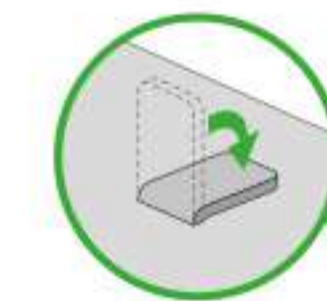
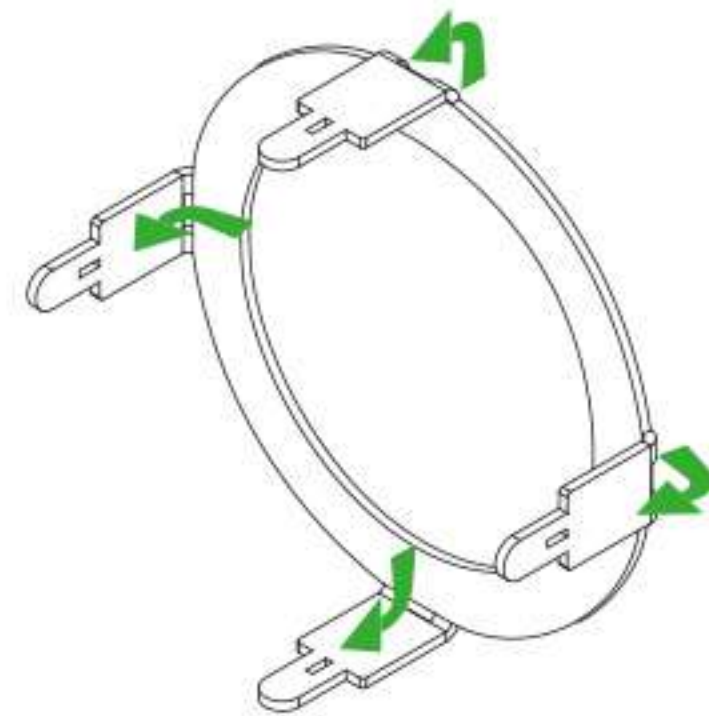
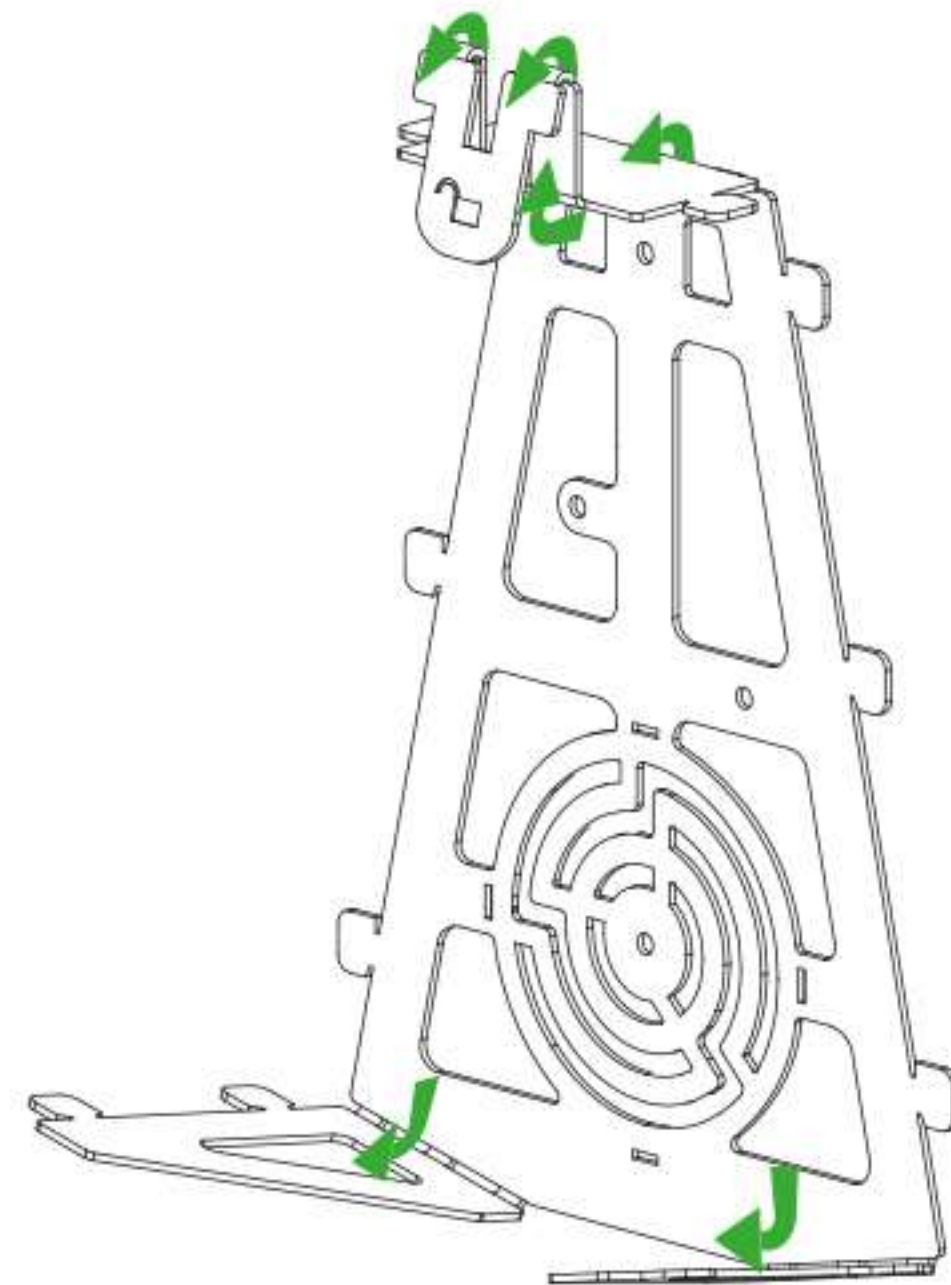

2

3

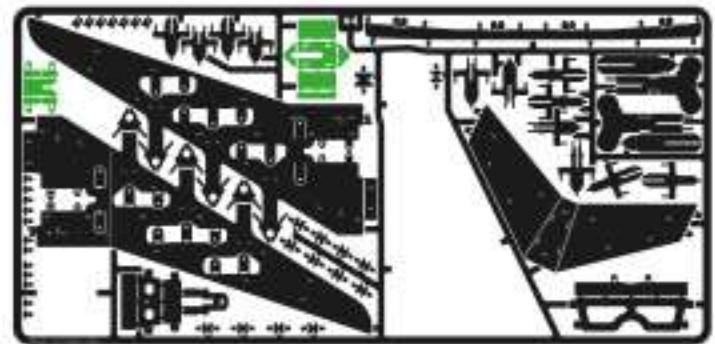

#4



#5

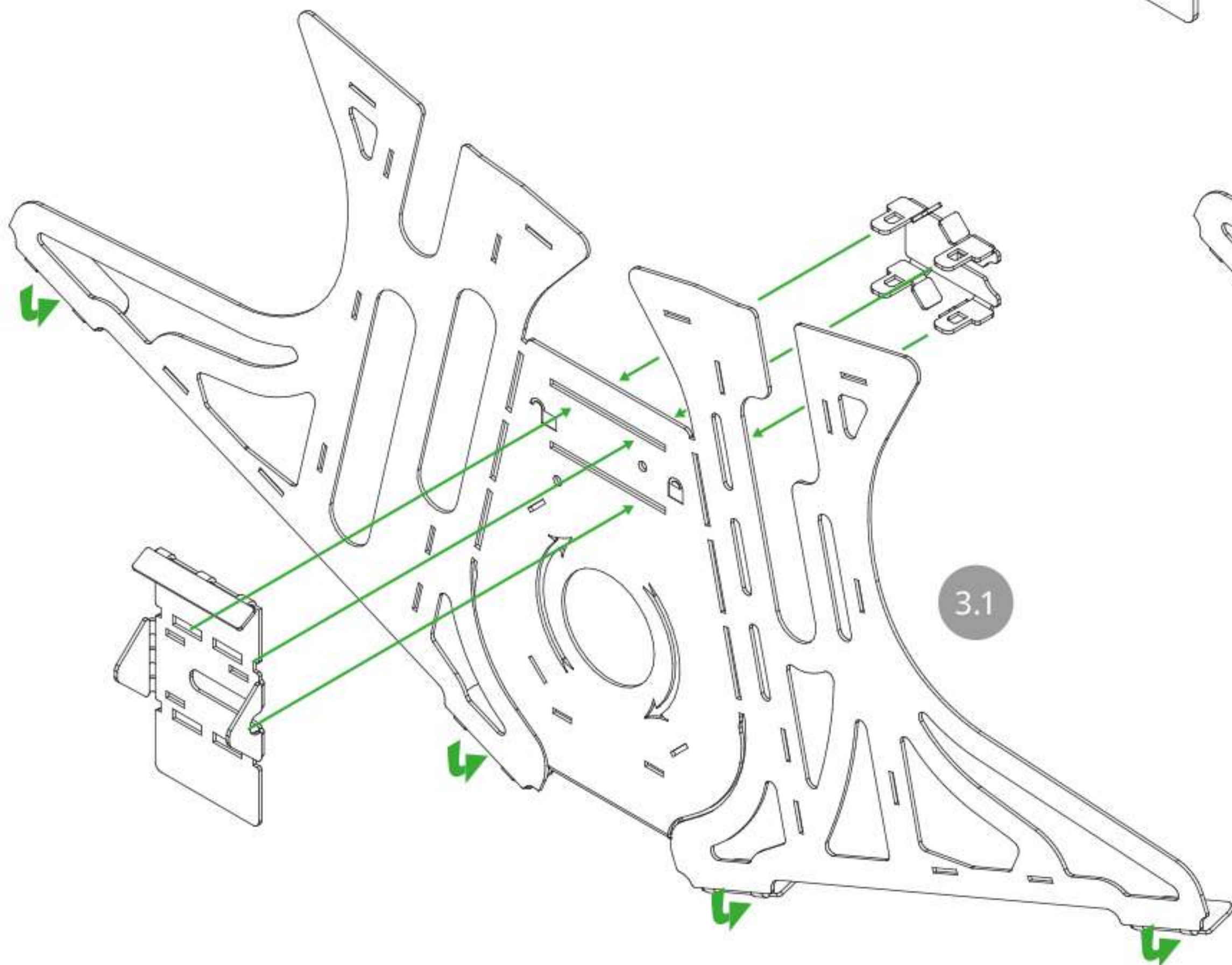
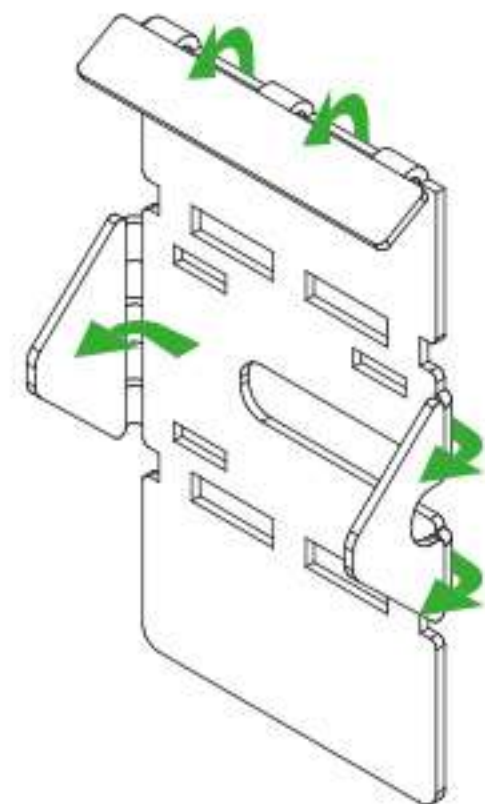
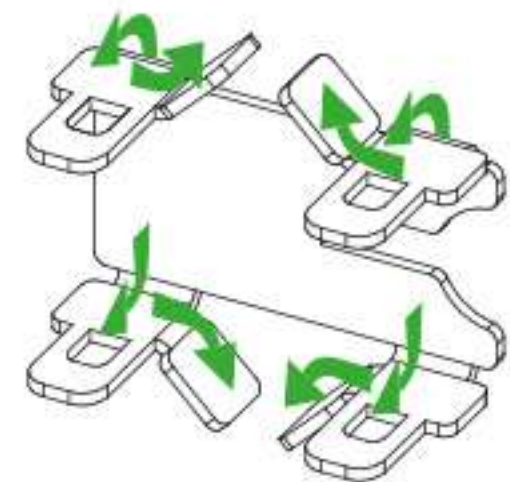

3.1

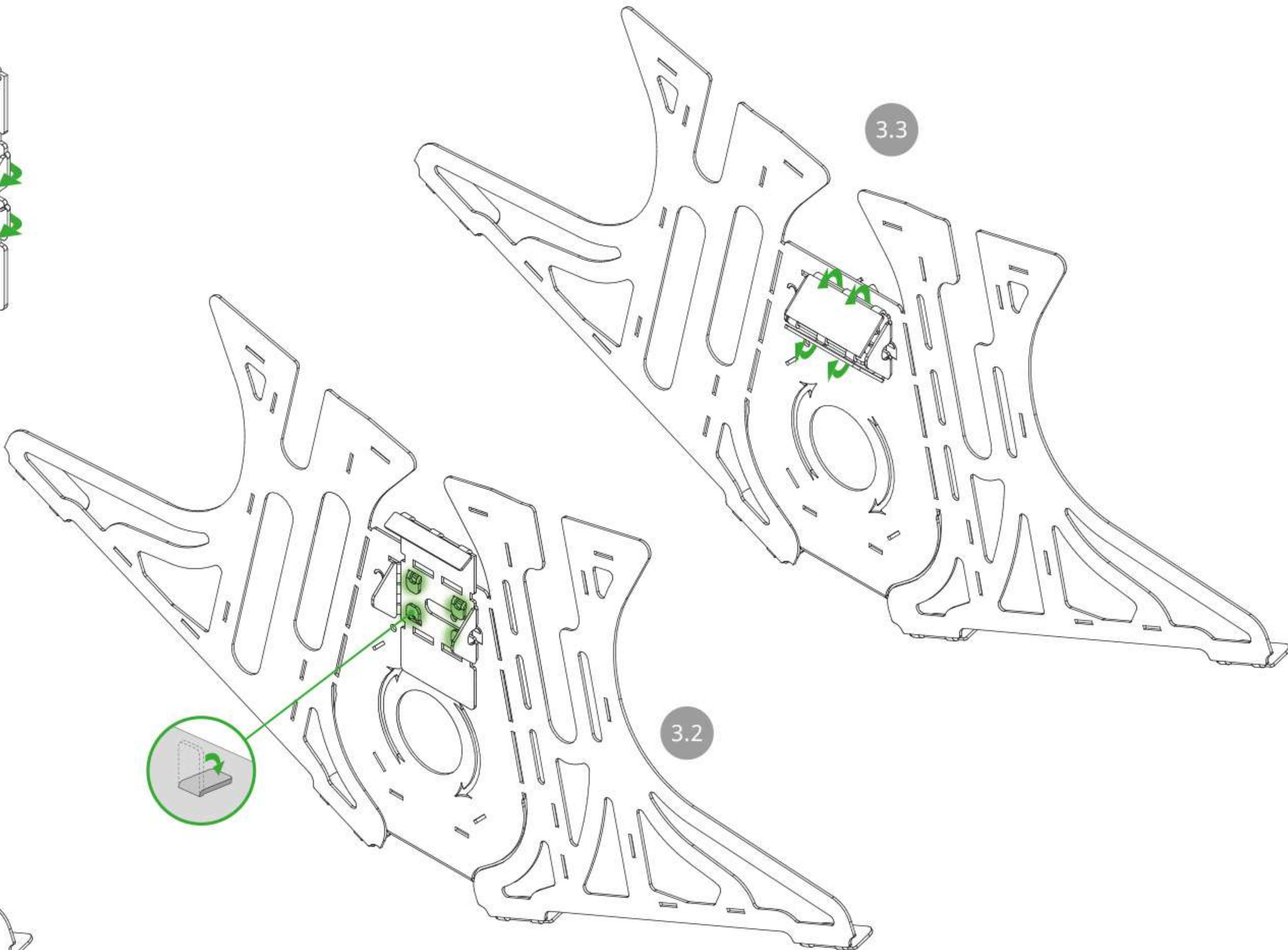

3.3

3.2

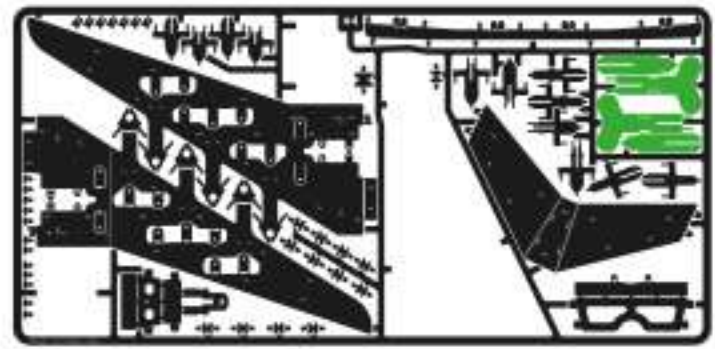

#4

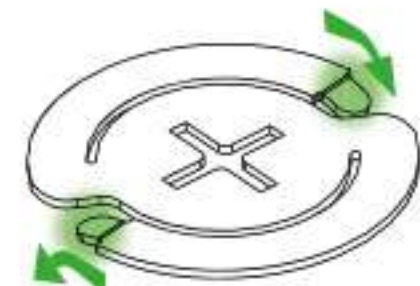
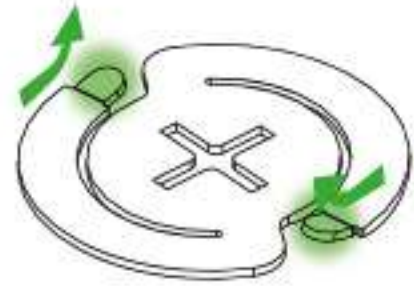

#5



G1

Assembly step 1

4.1

4.2

4.3

4.4

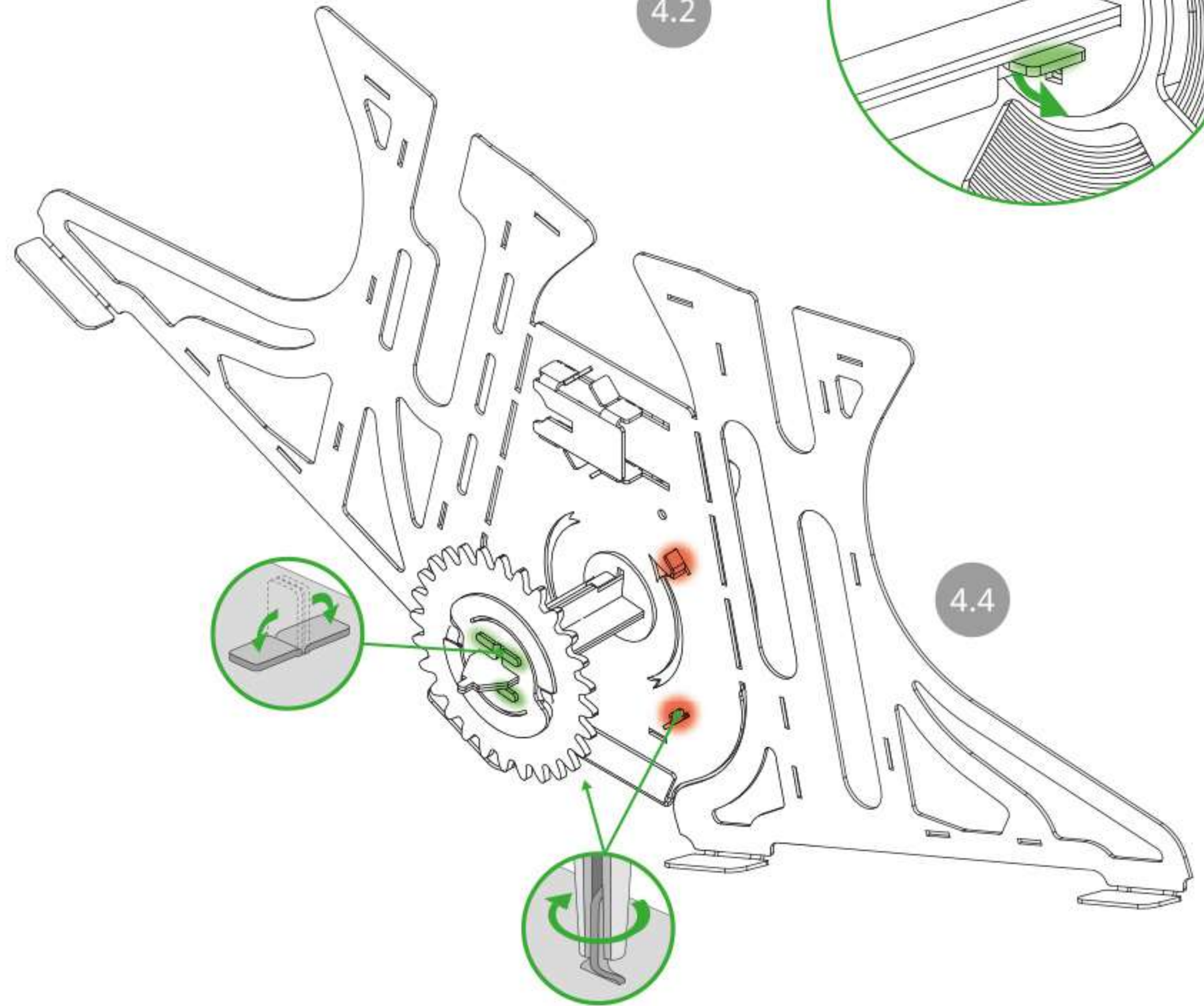
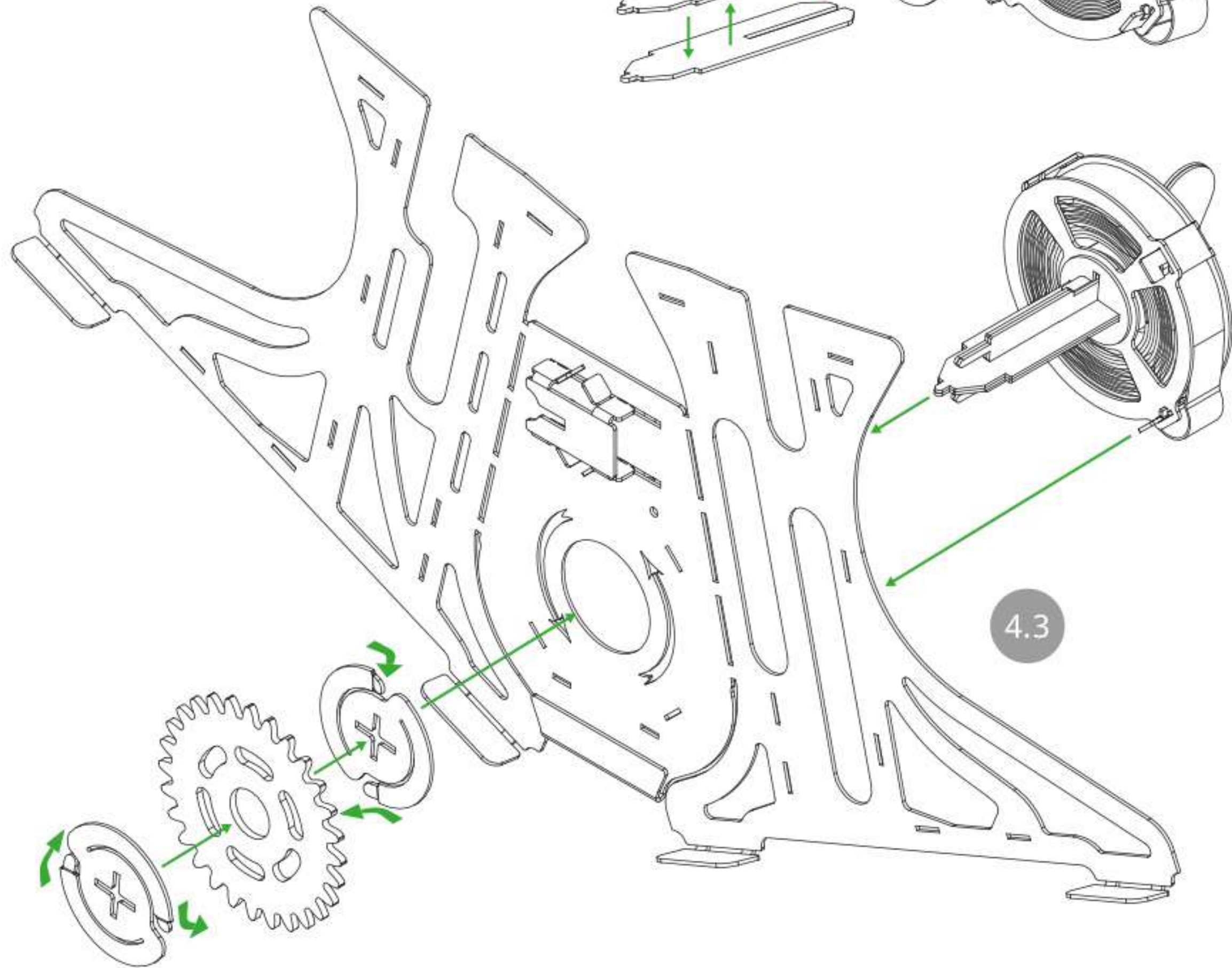

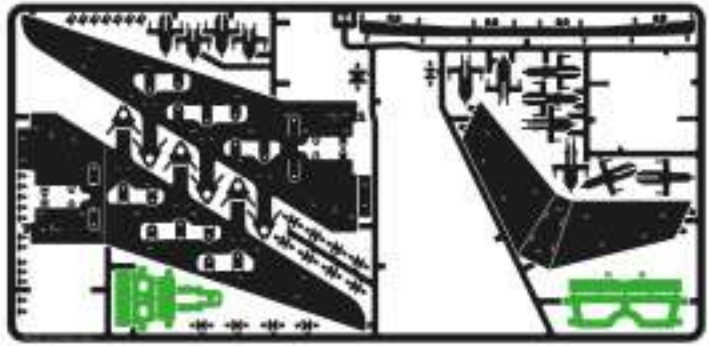

#4

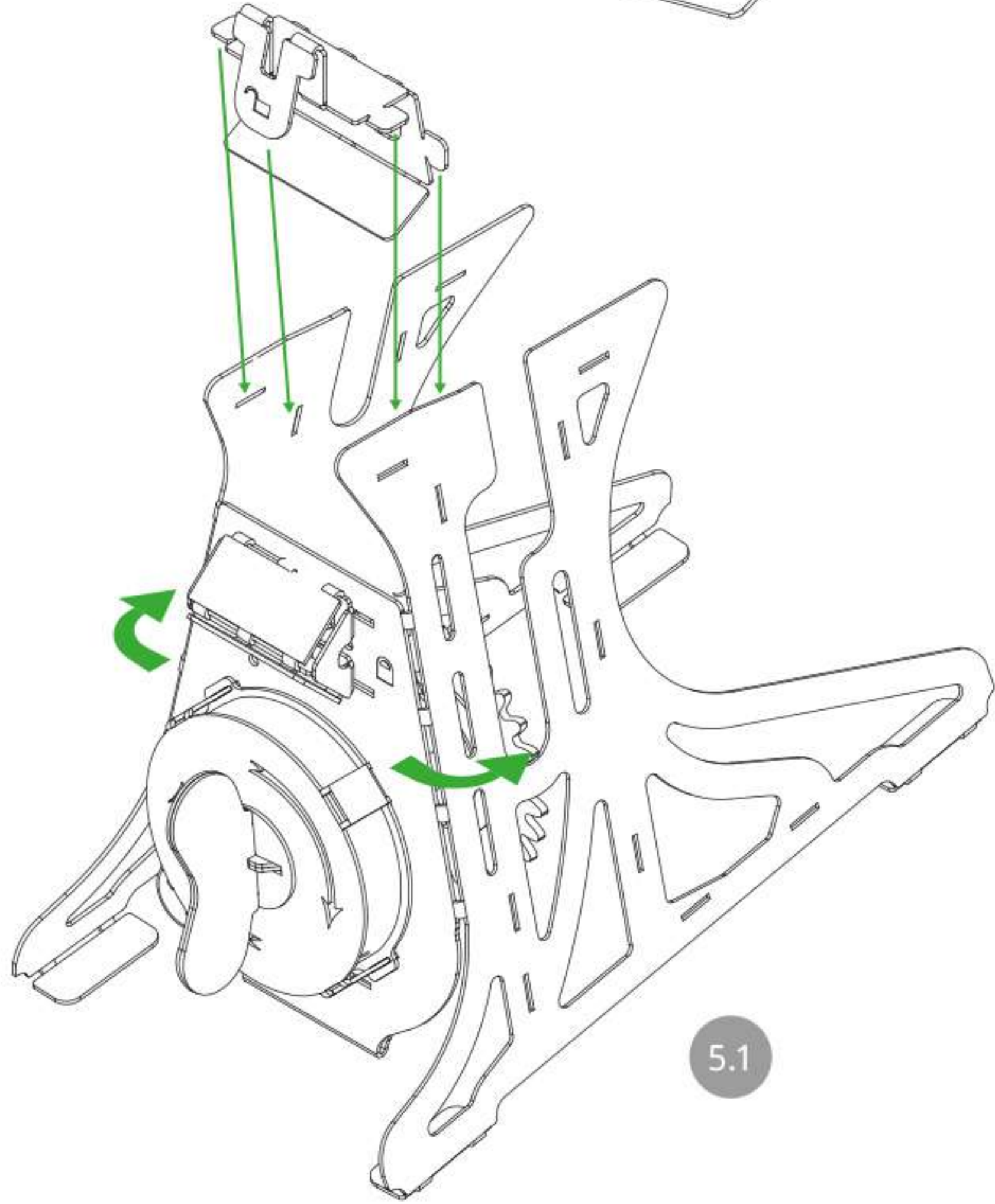
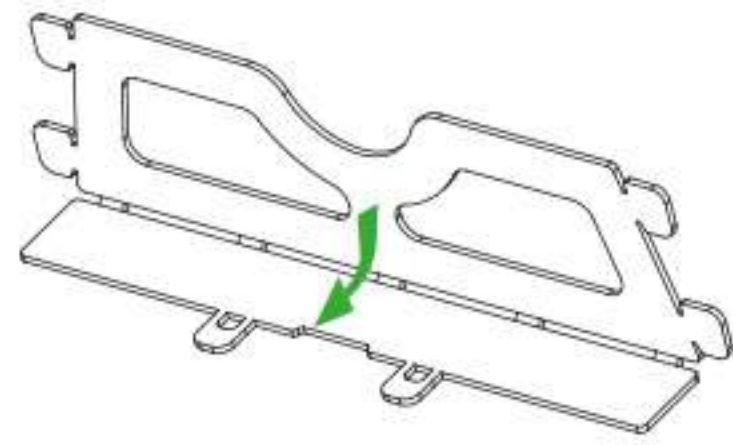
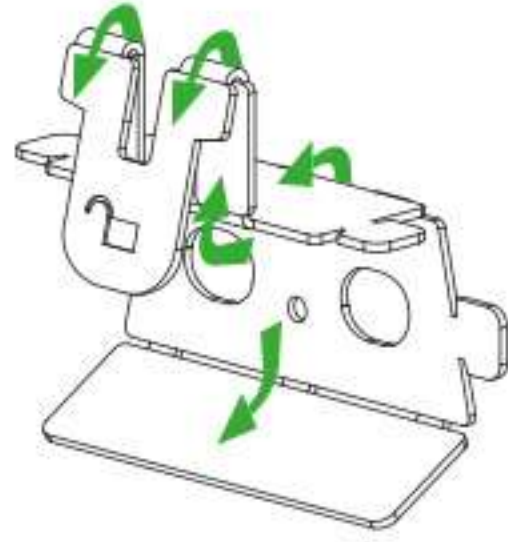

5.1

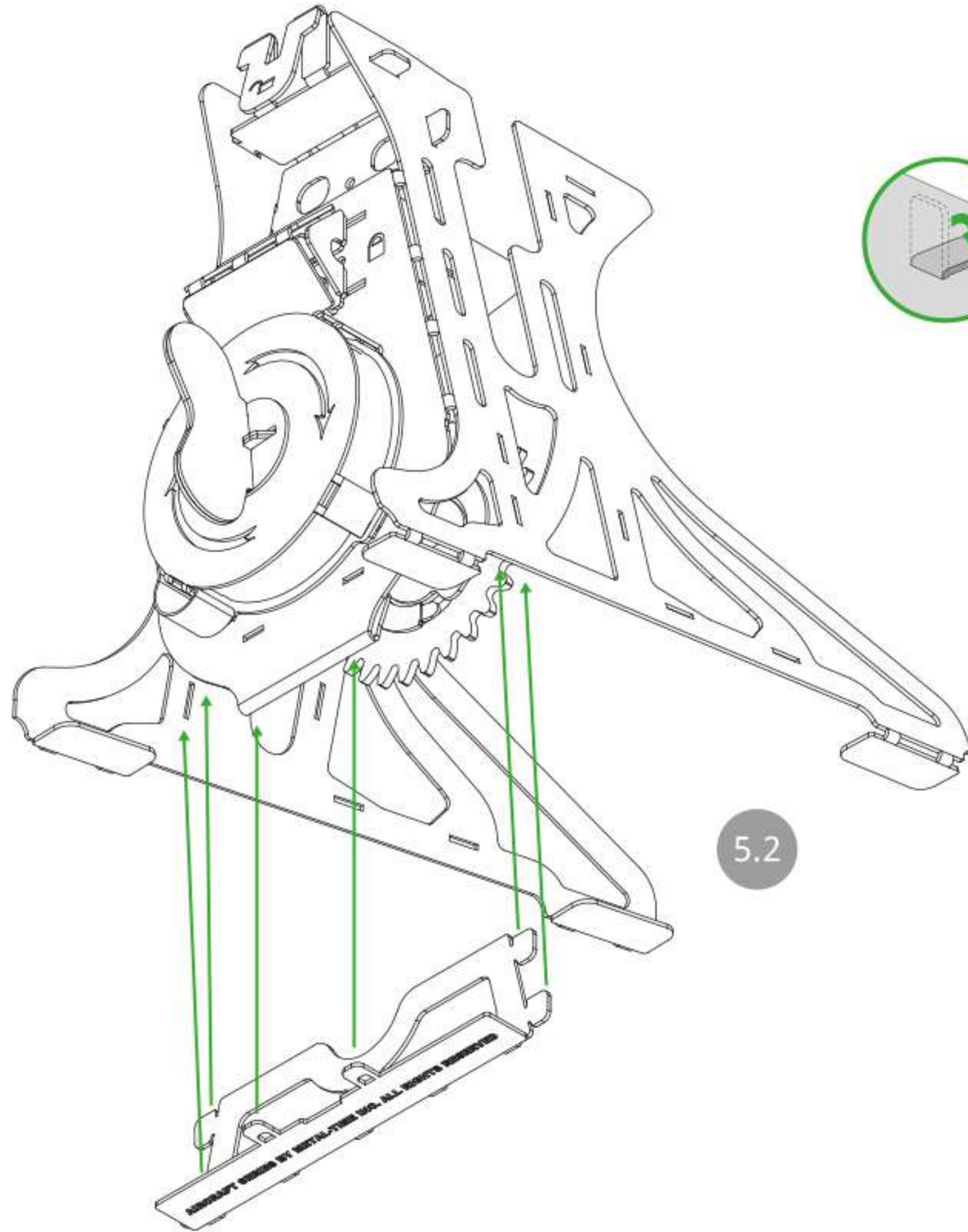

5.2

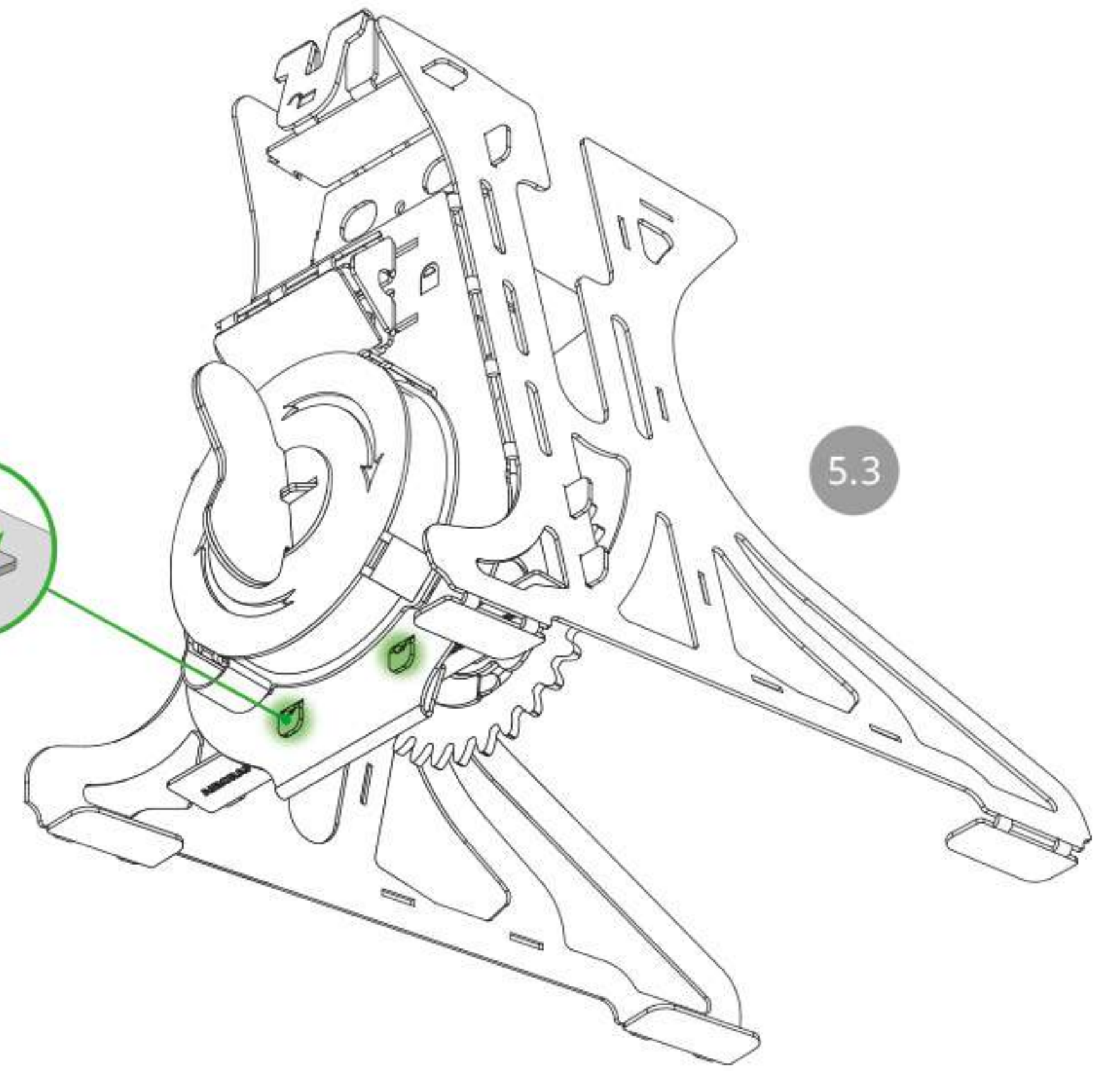
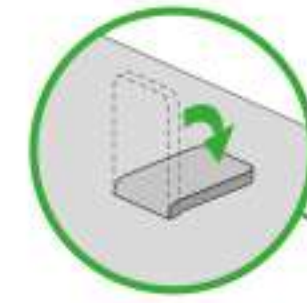

5.3

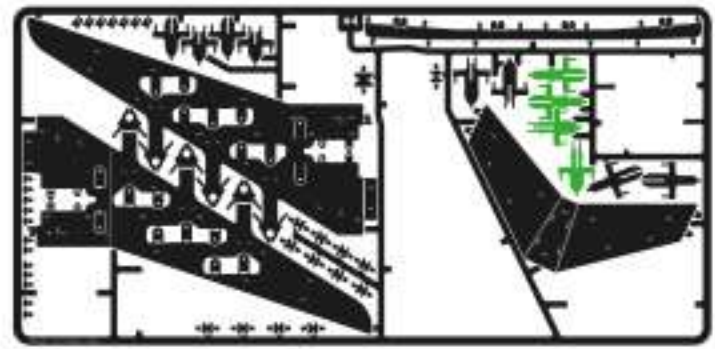

#4

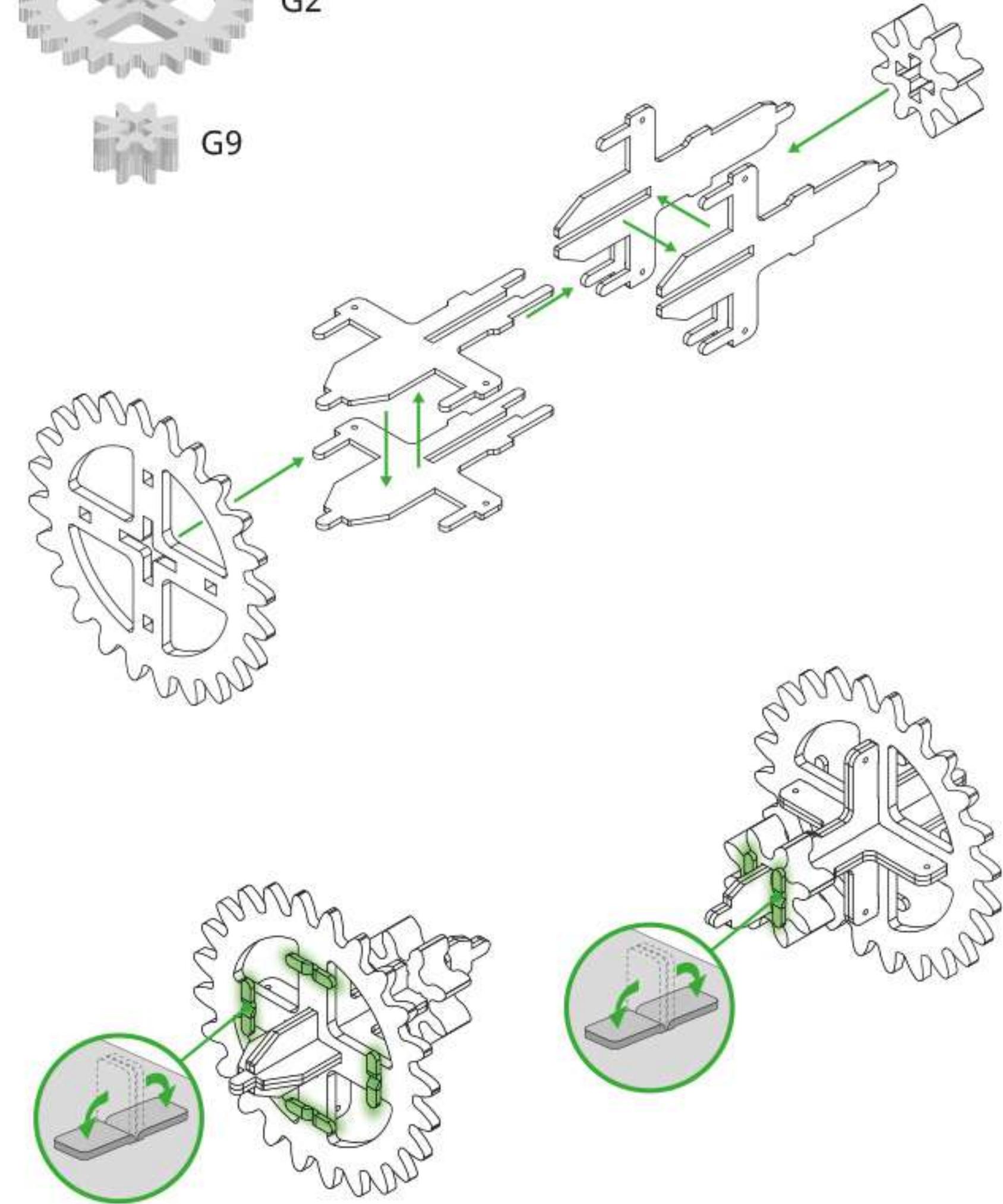
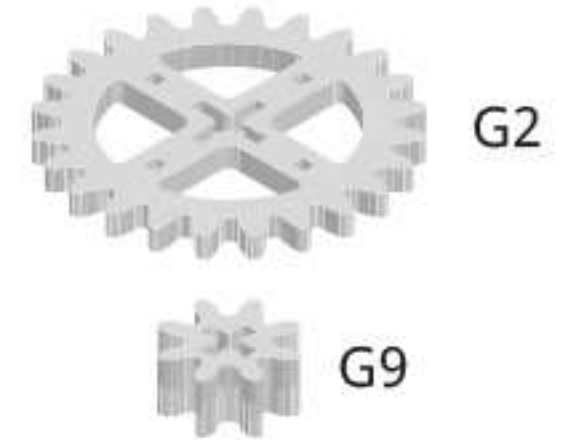

6

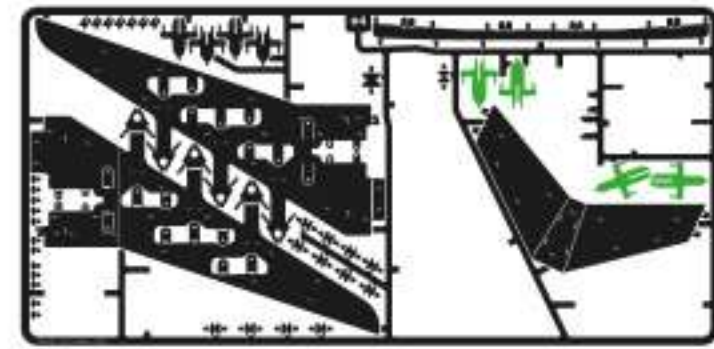

#4

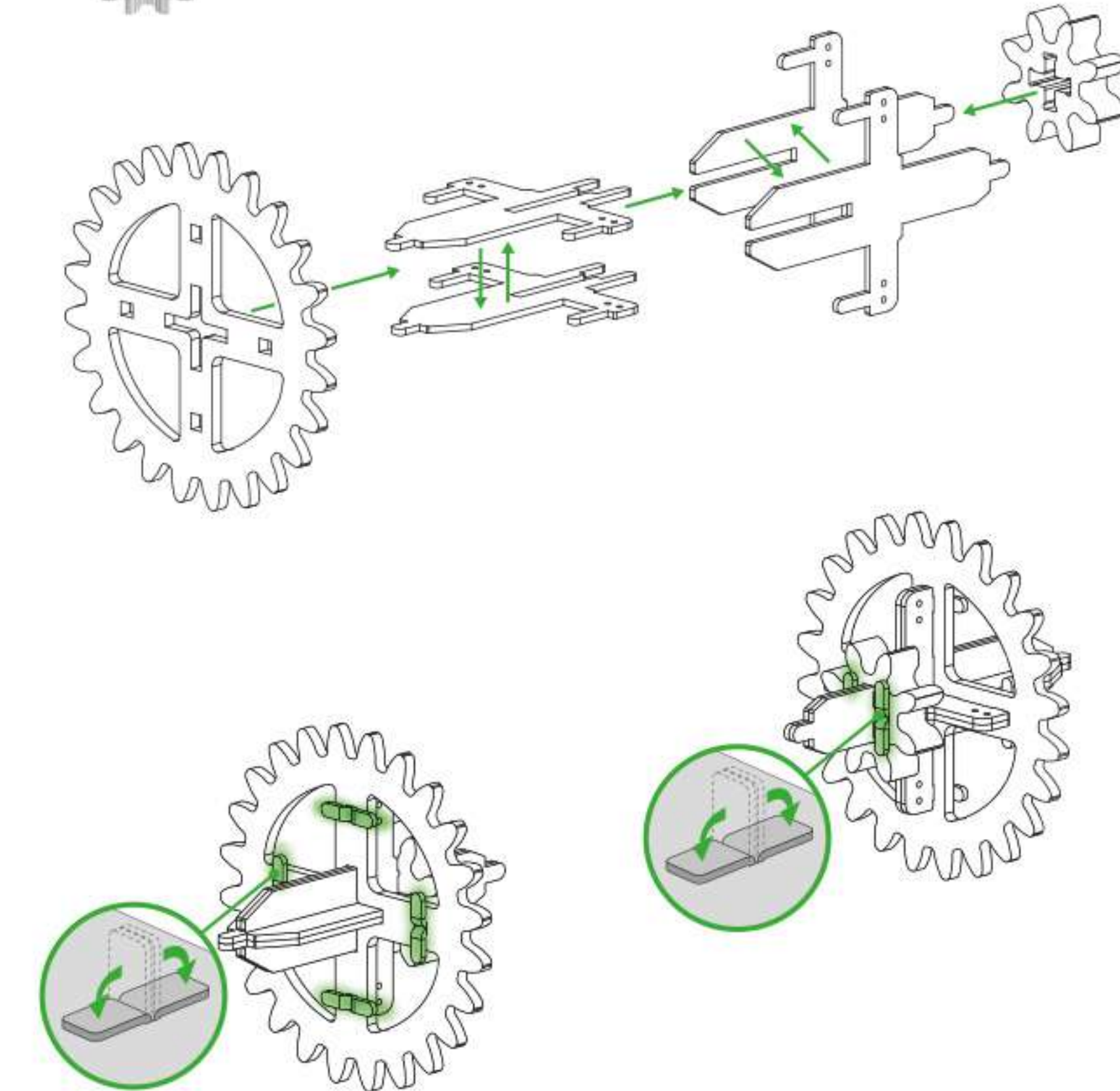
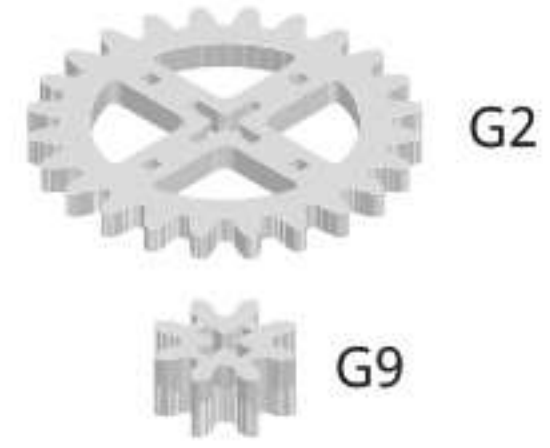

7

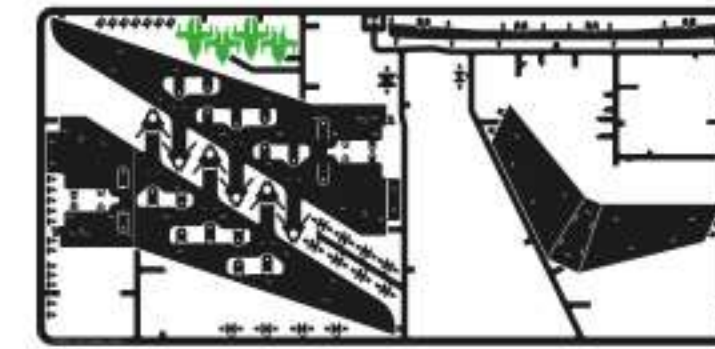

#4

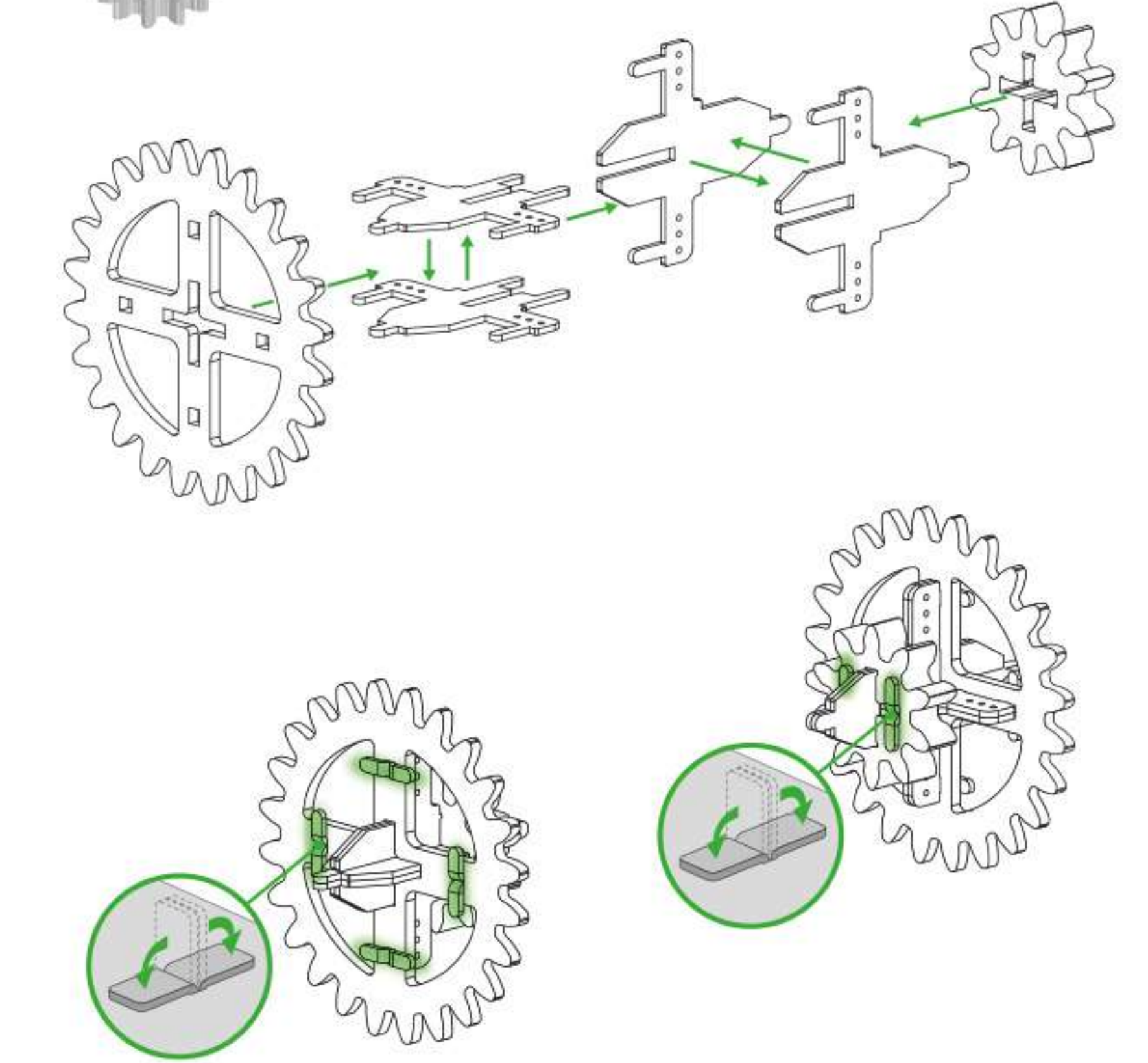
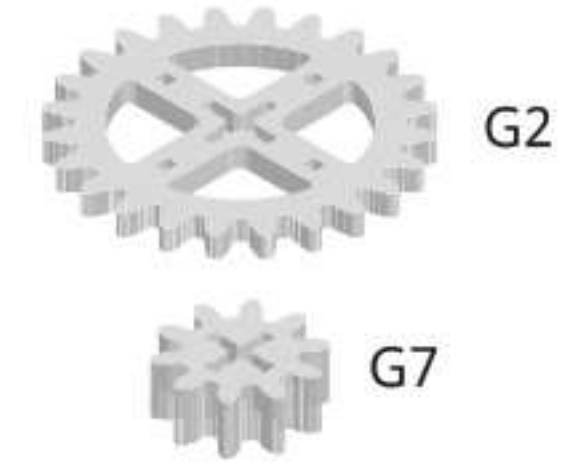

8

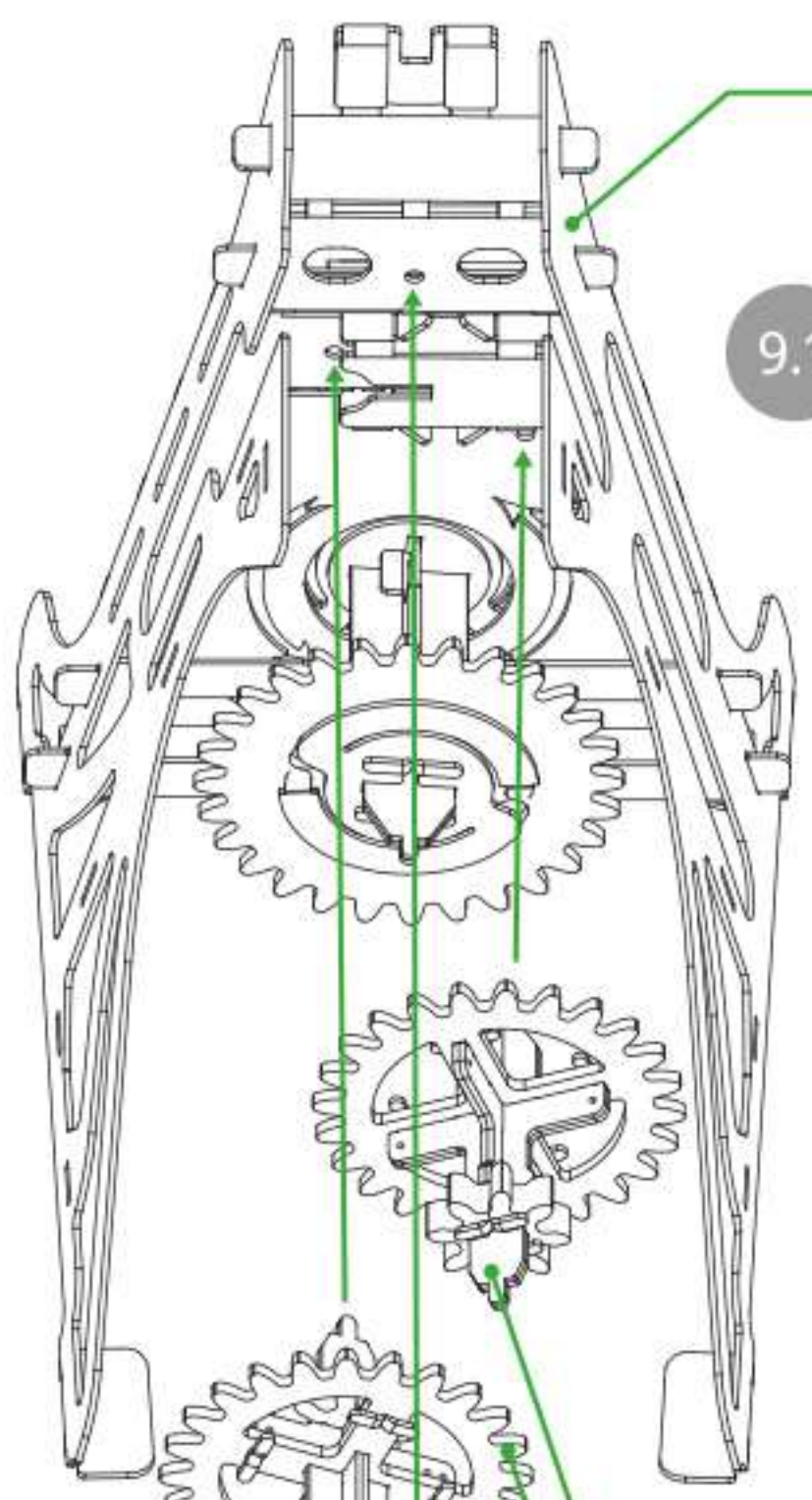

Assembly step 5

9.1

Assembly step 6

Assembly step 7

Assembly step 8

Assembly step 2

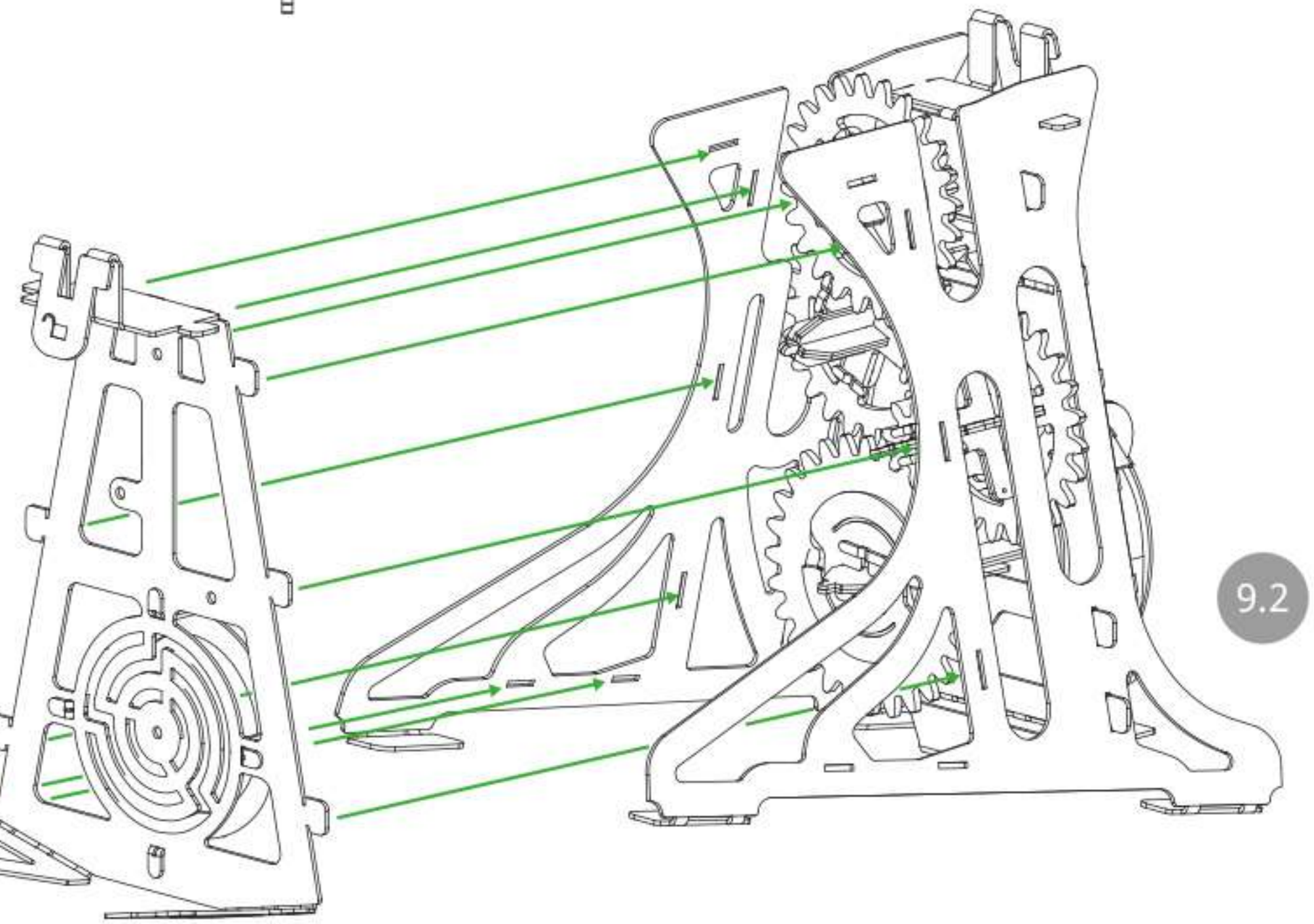
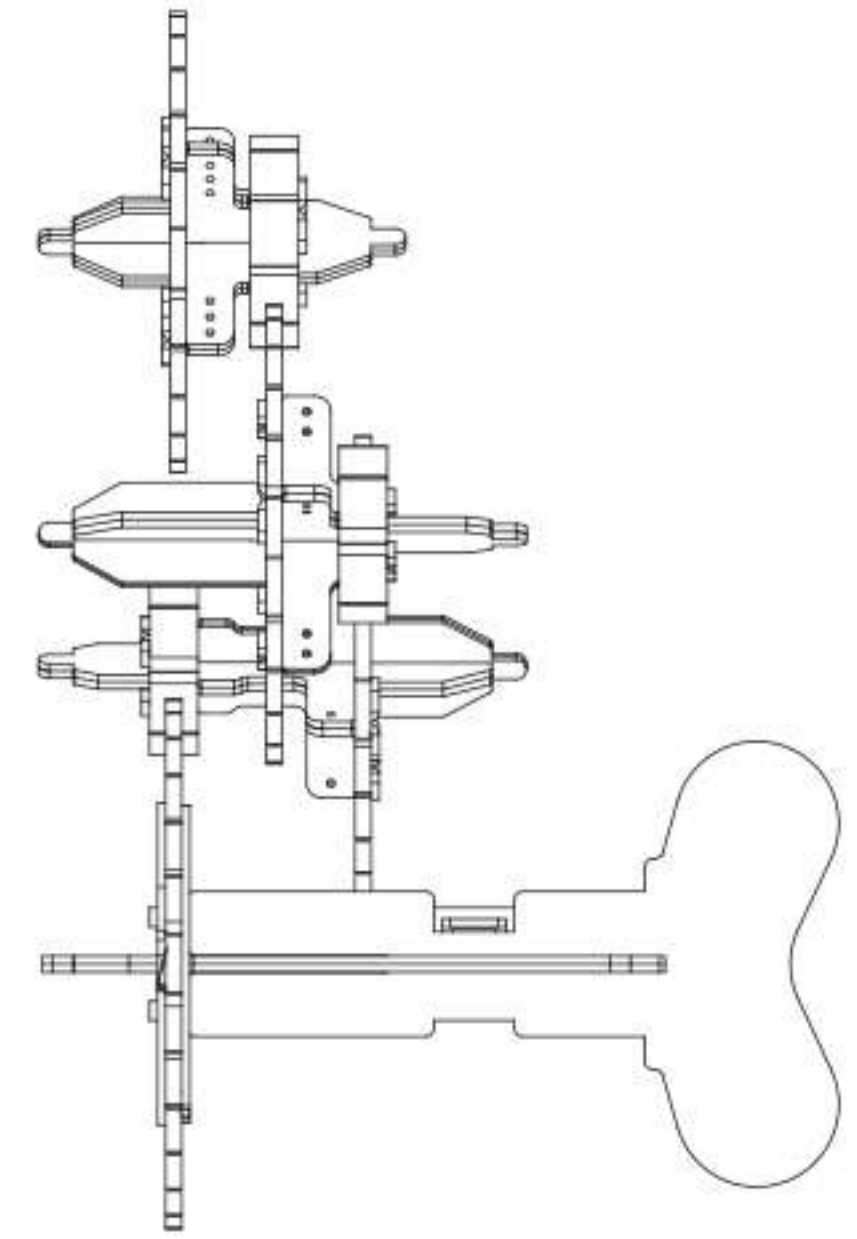

9.2

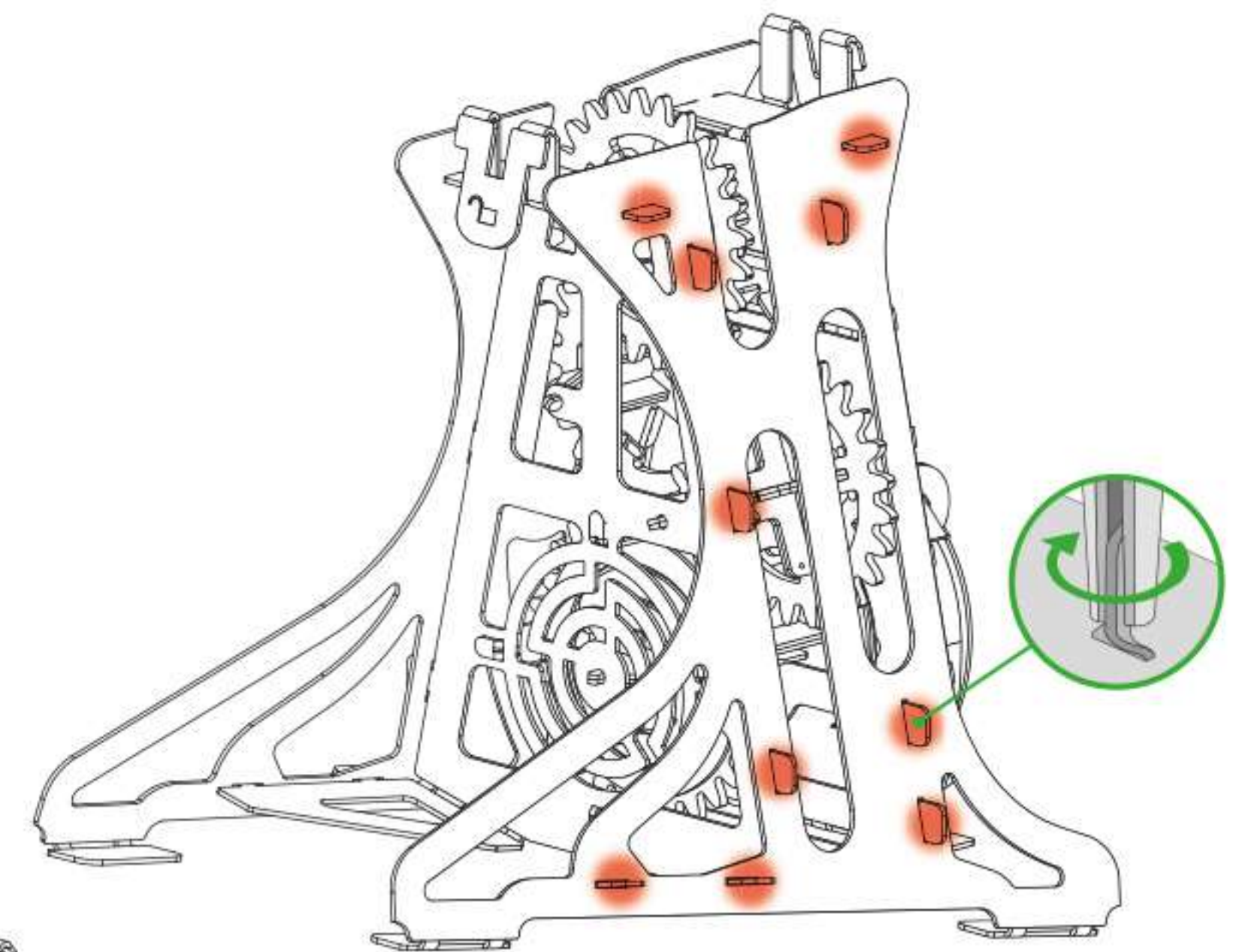

9.3

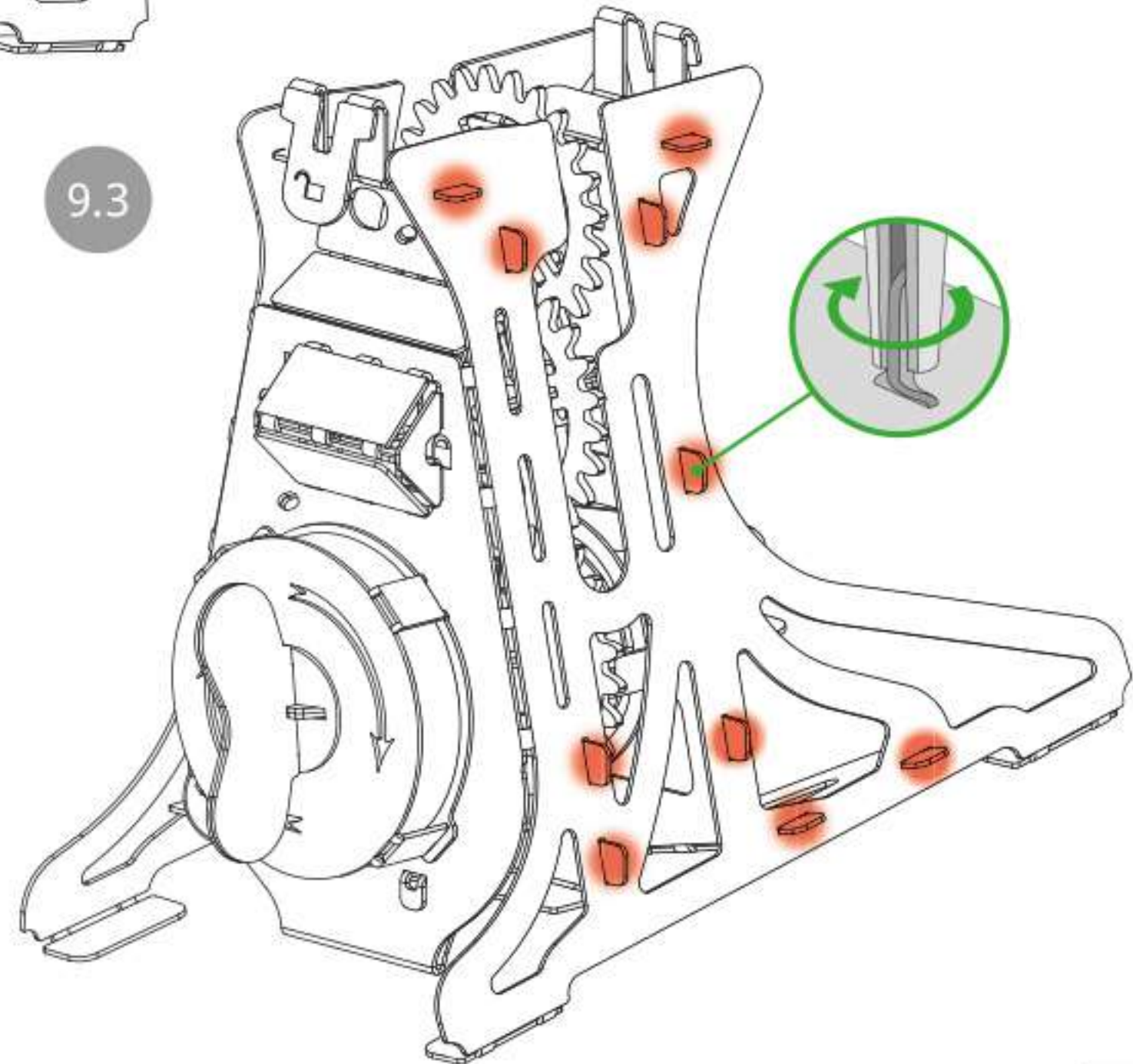

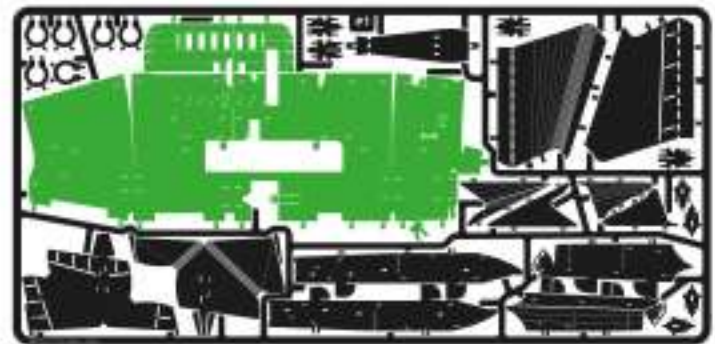

#1

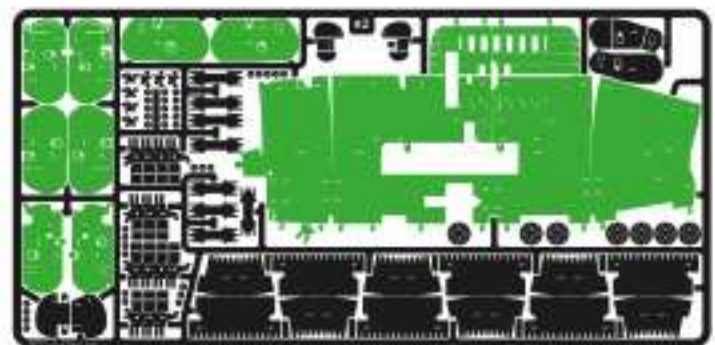

#2

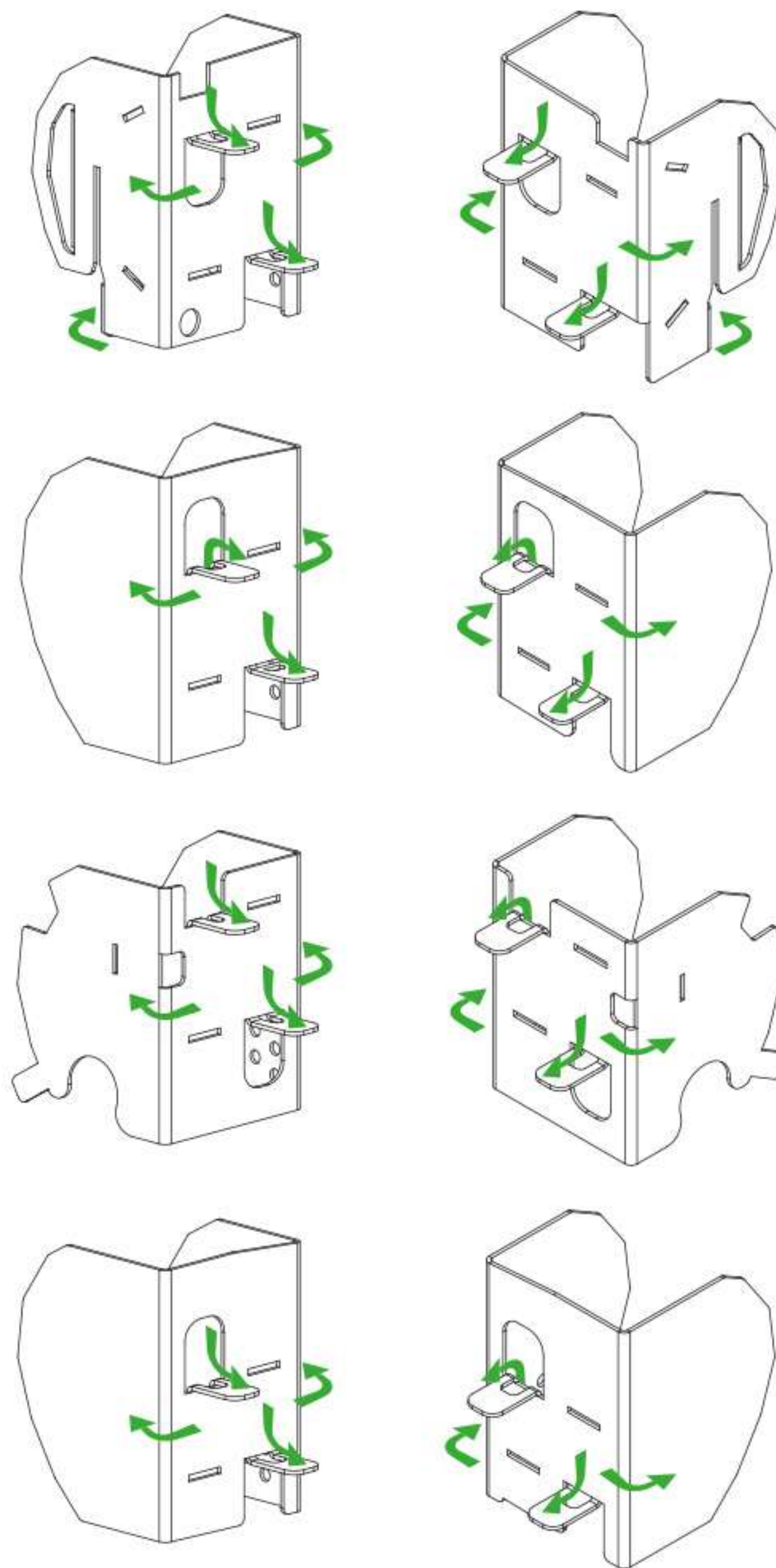
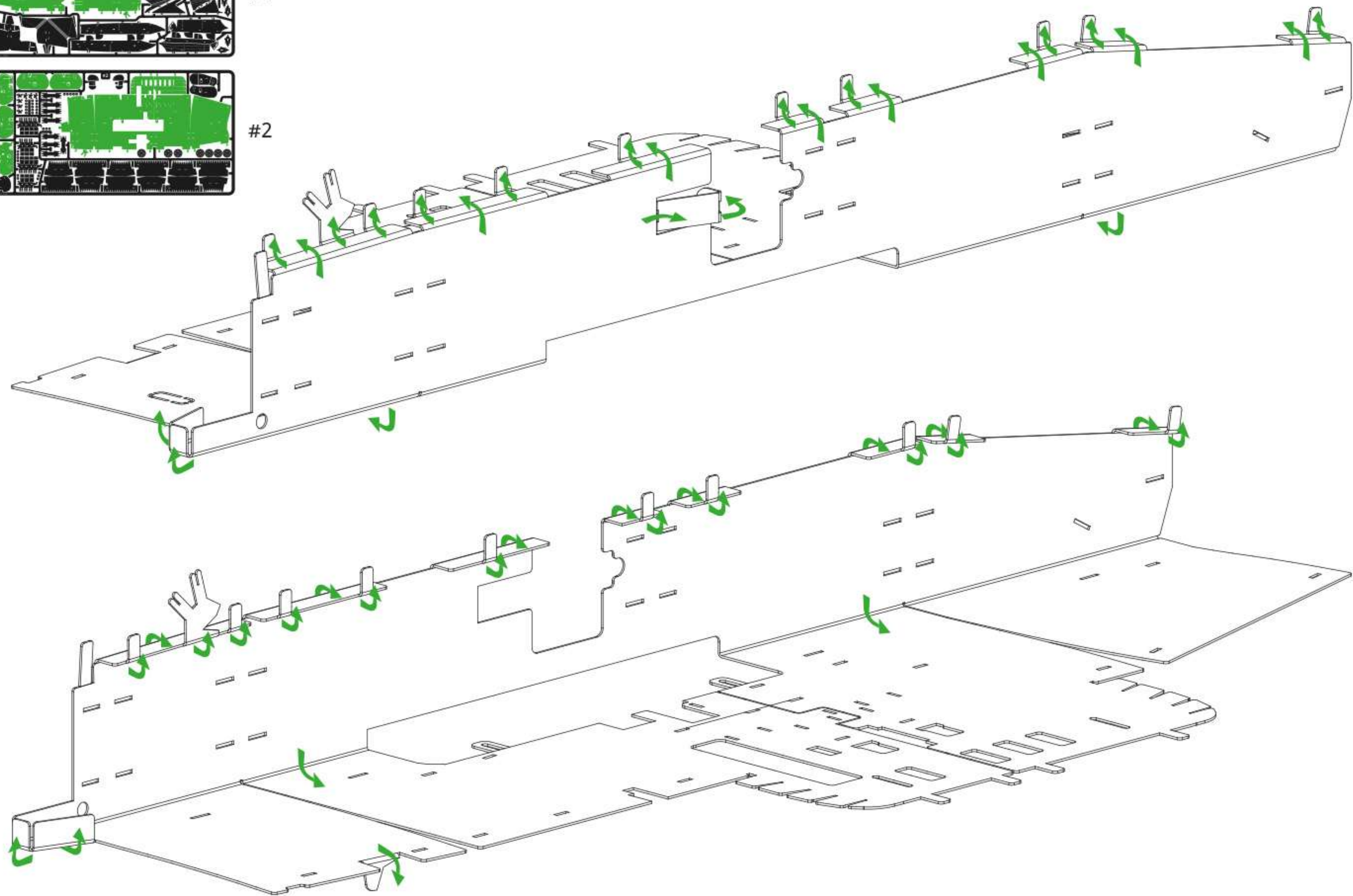

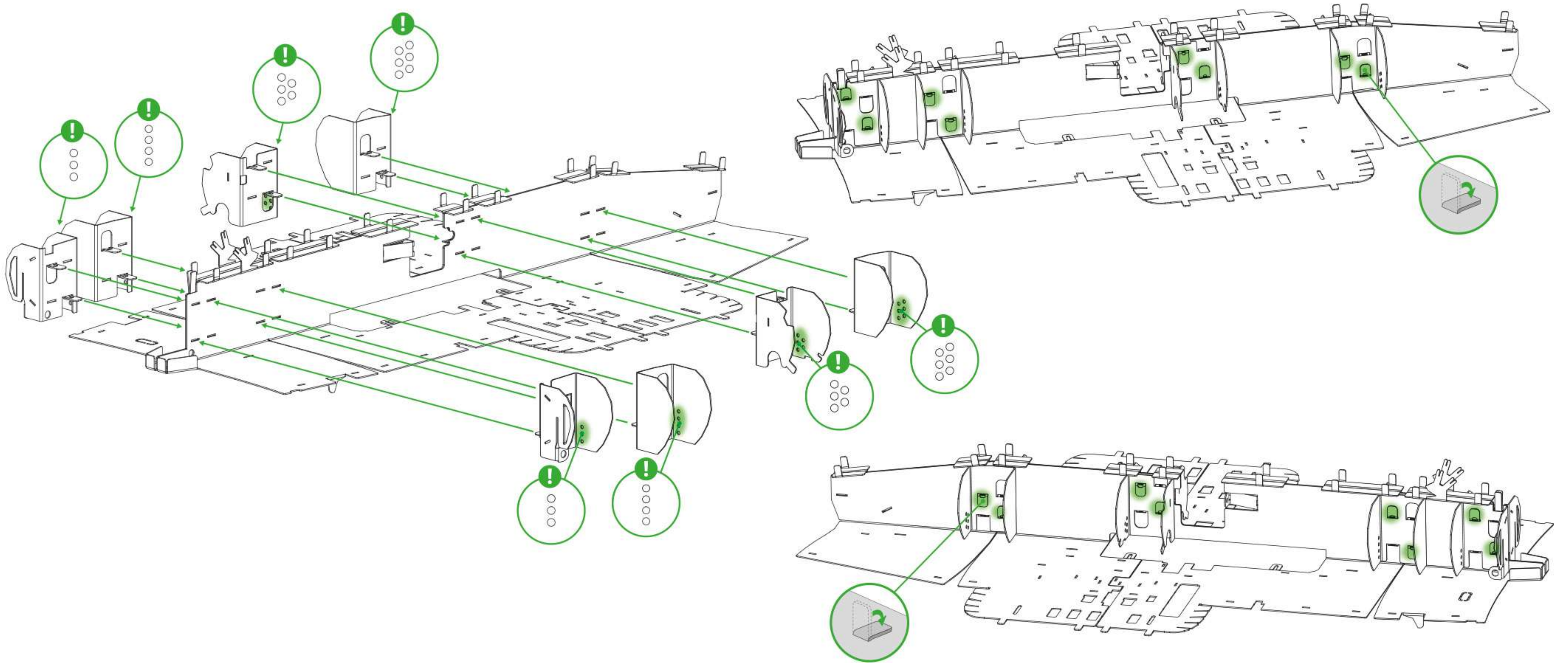

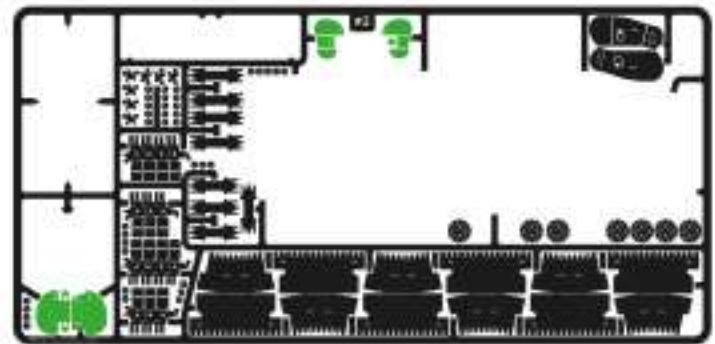

#2



#3

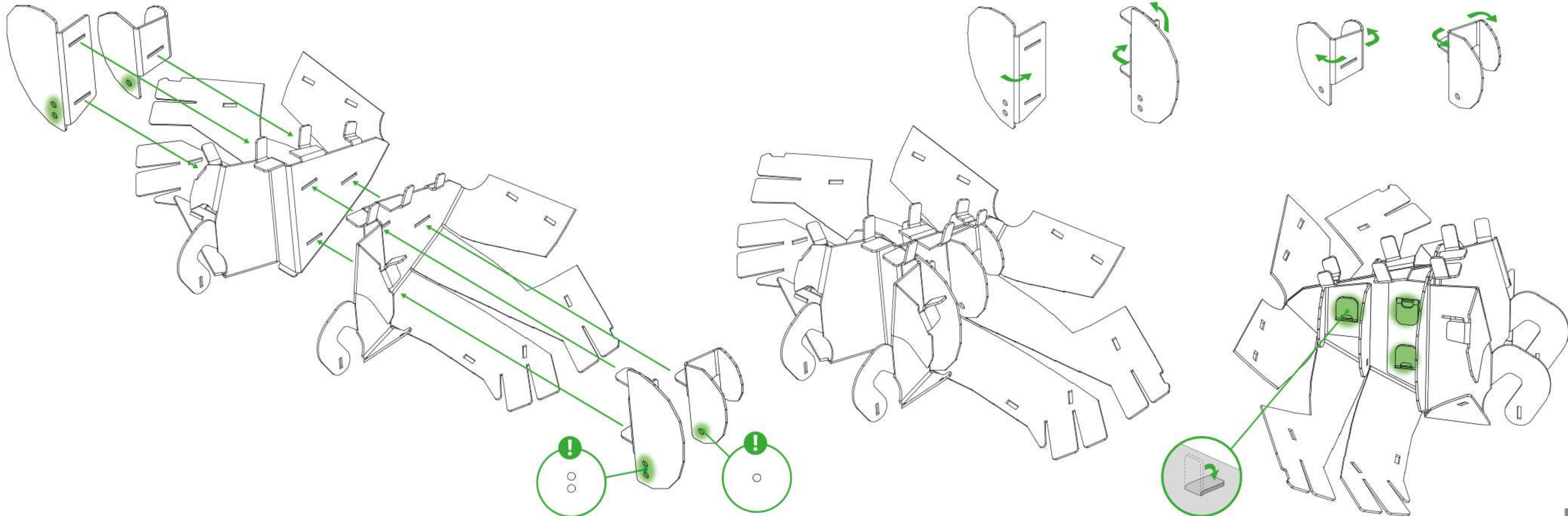
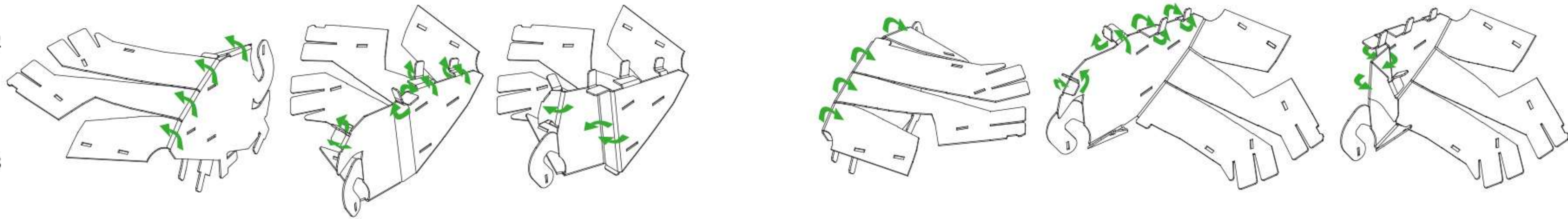

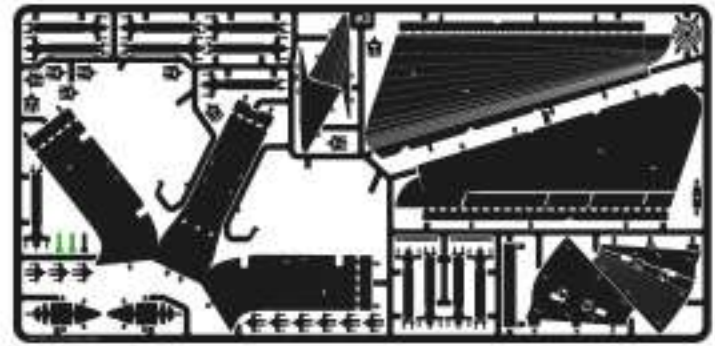

#3

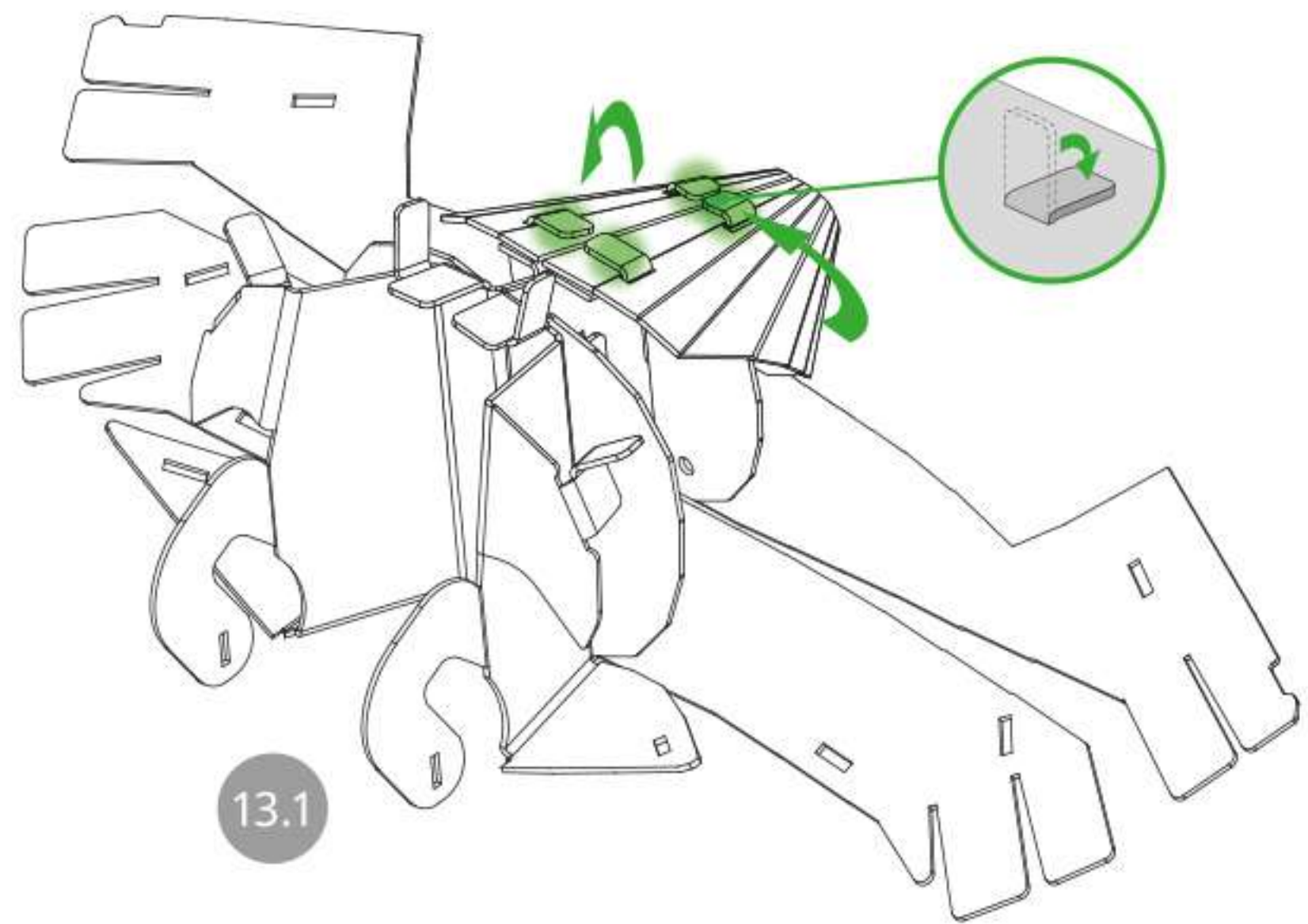
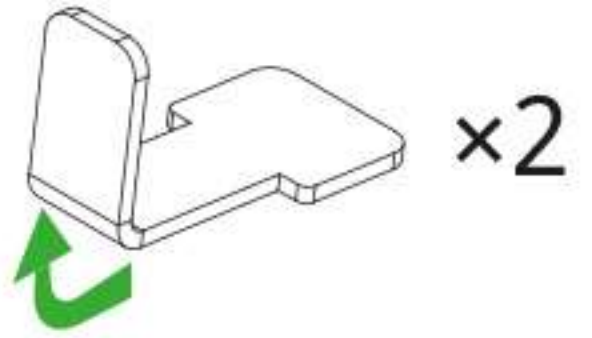

13.1

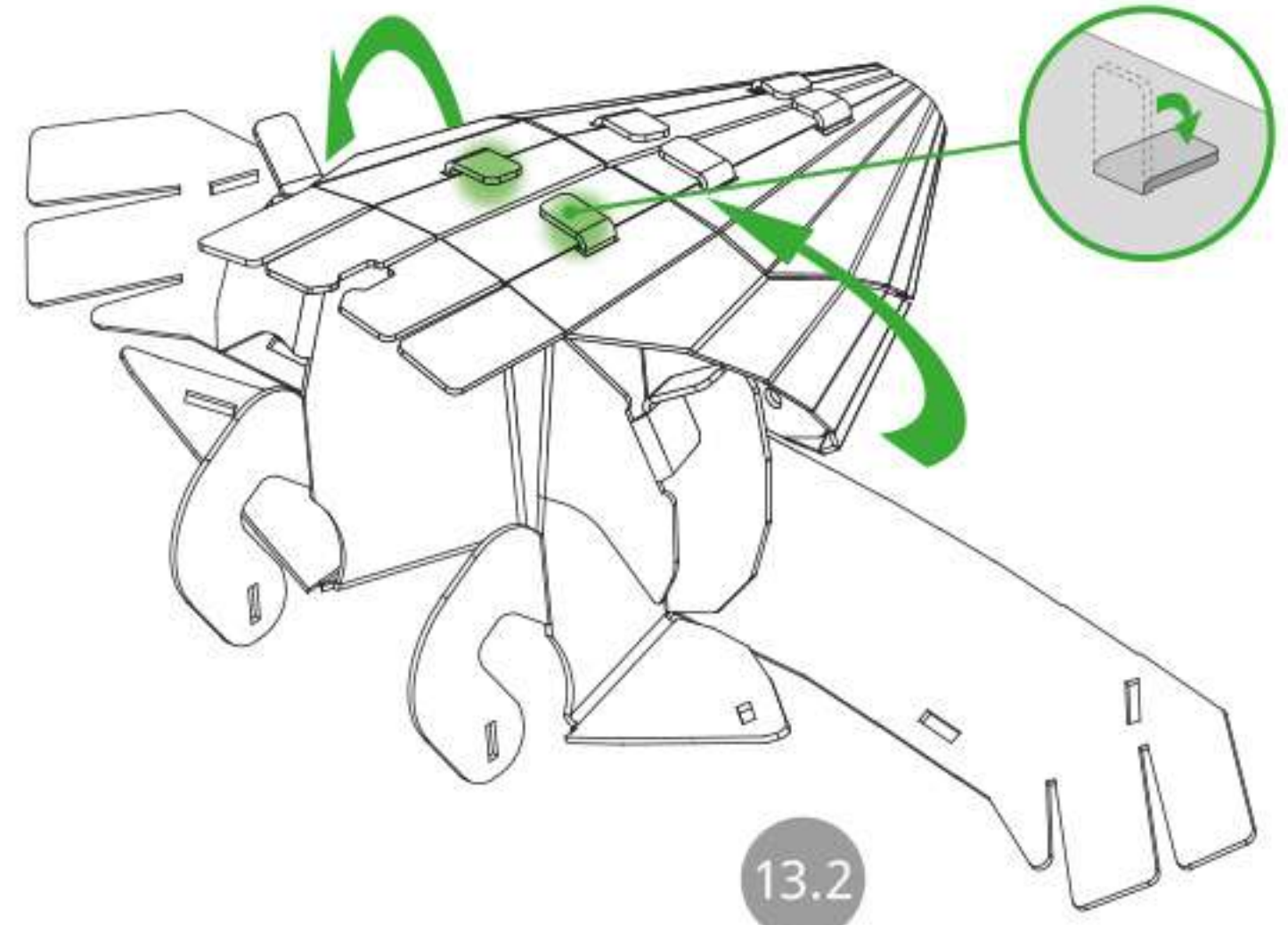

13.2

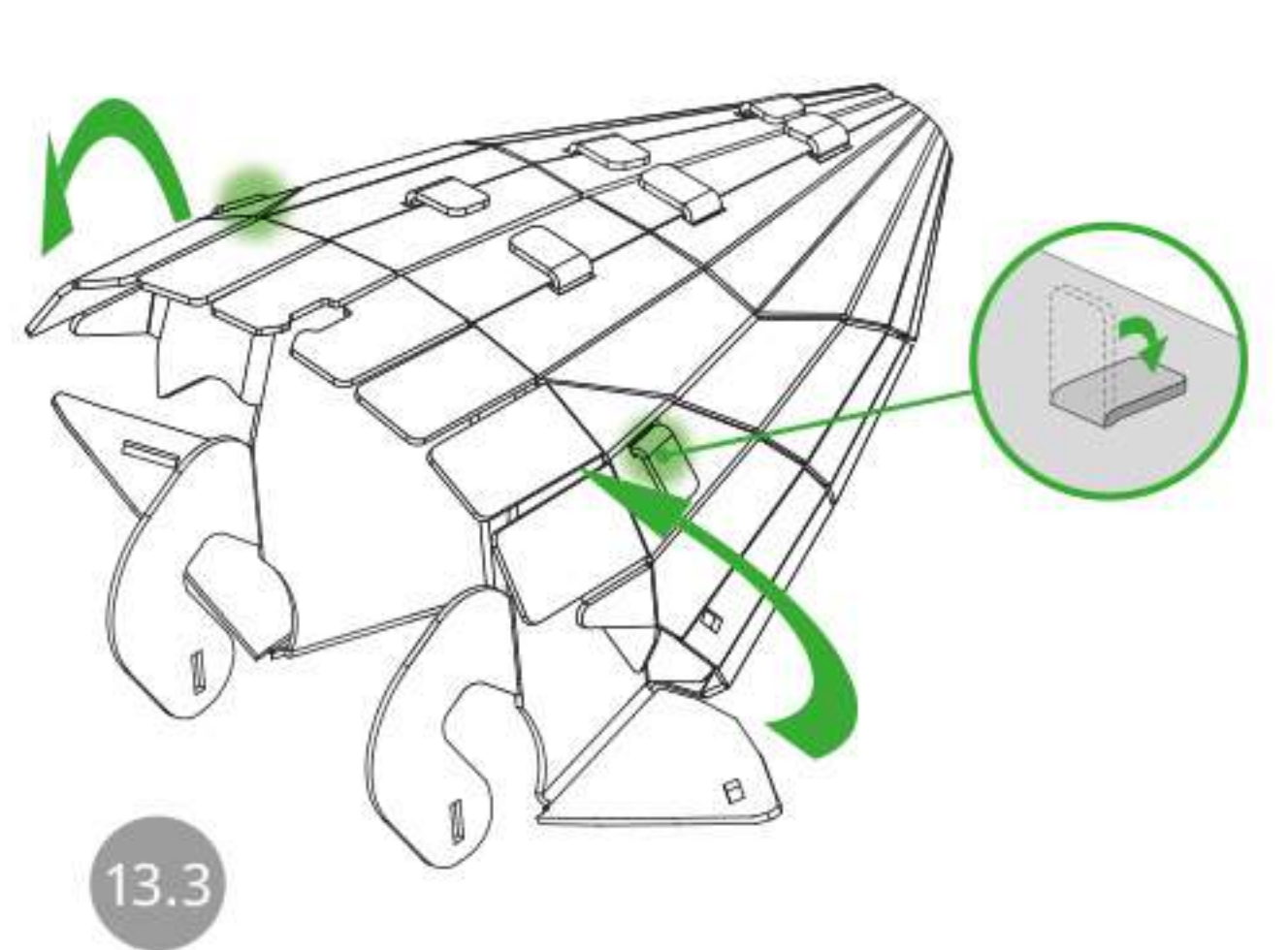

13.3

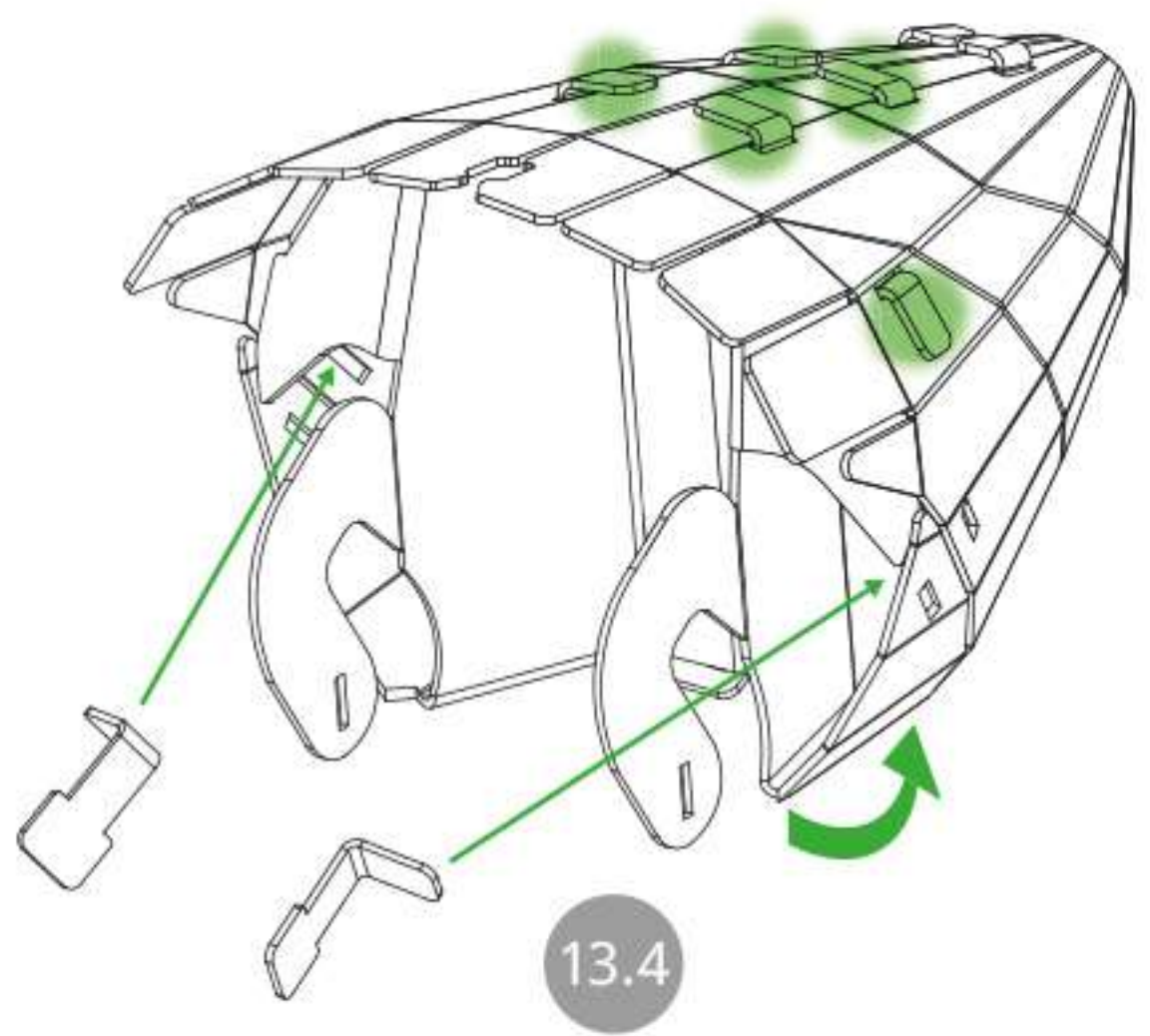

13.4

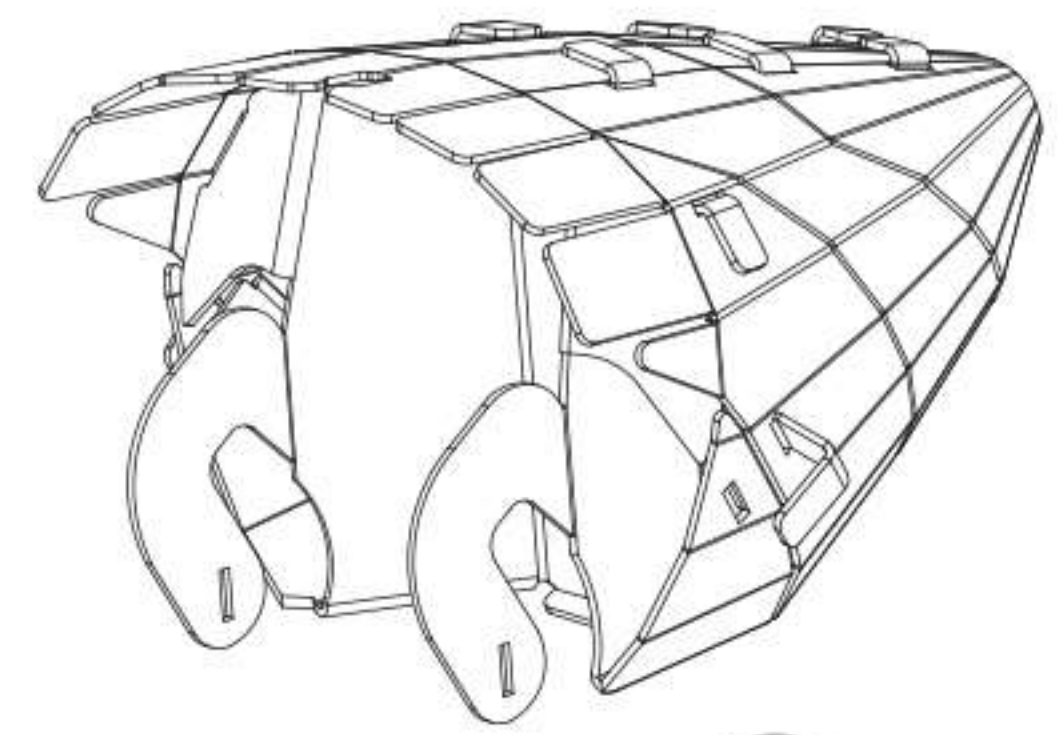

13.5

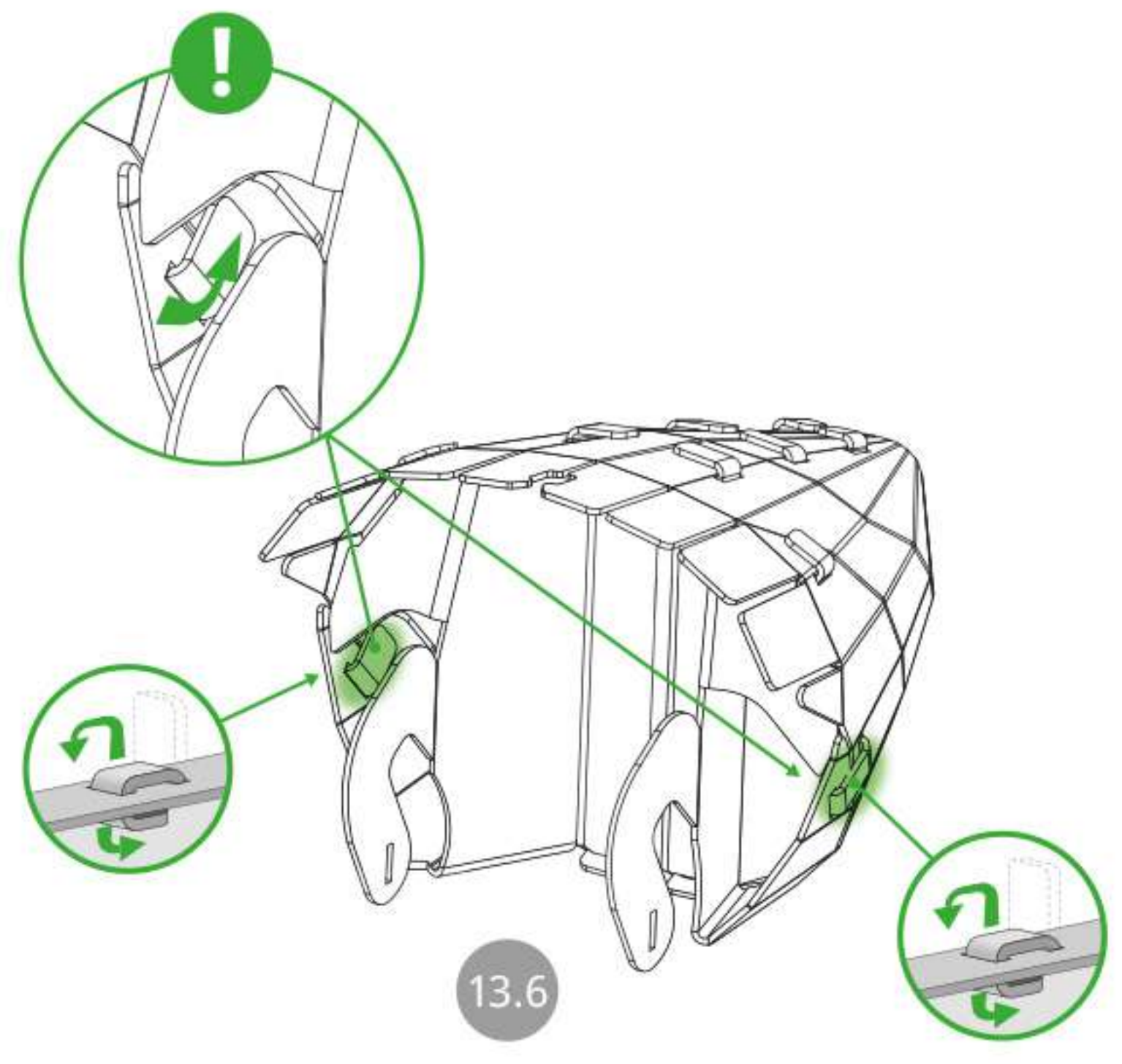

13.6

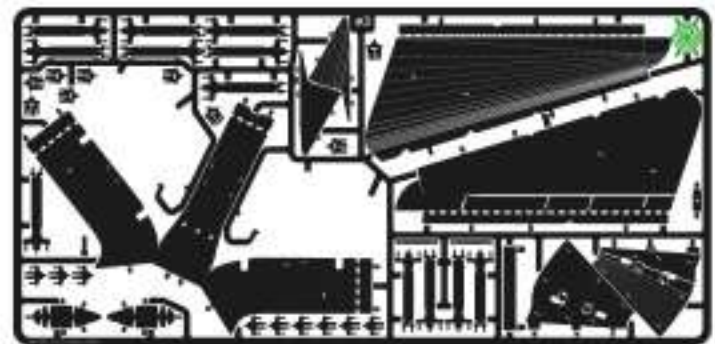

#3

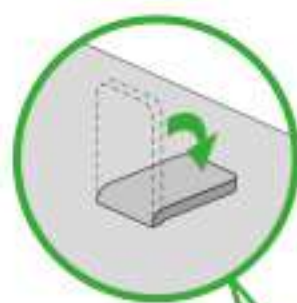
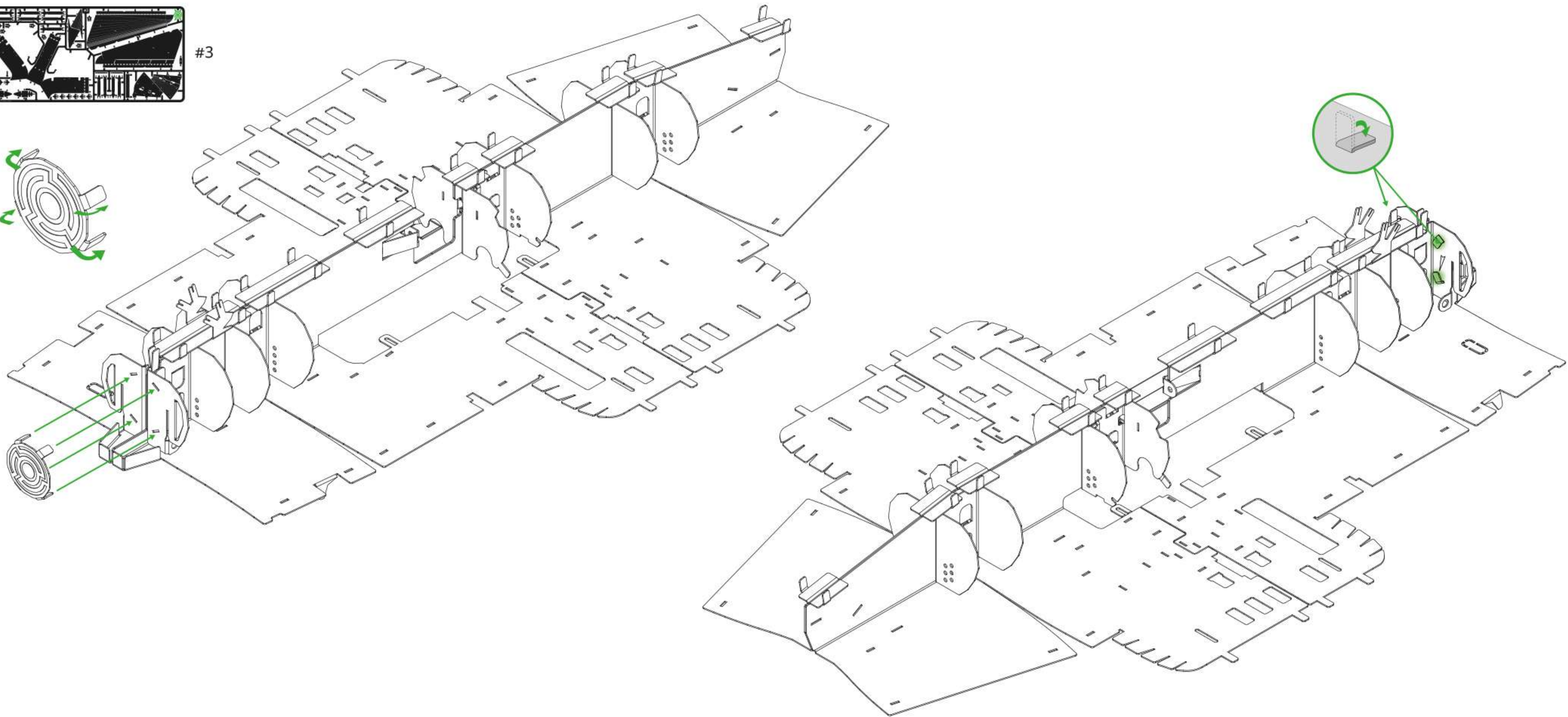
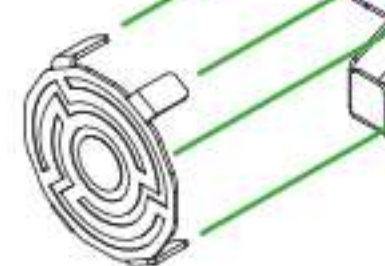

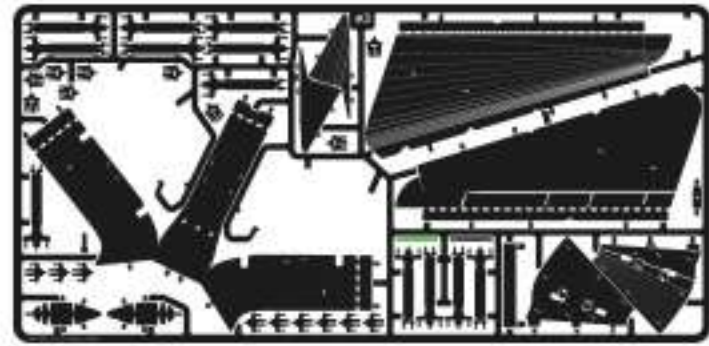

#3

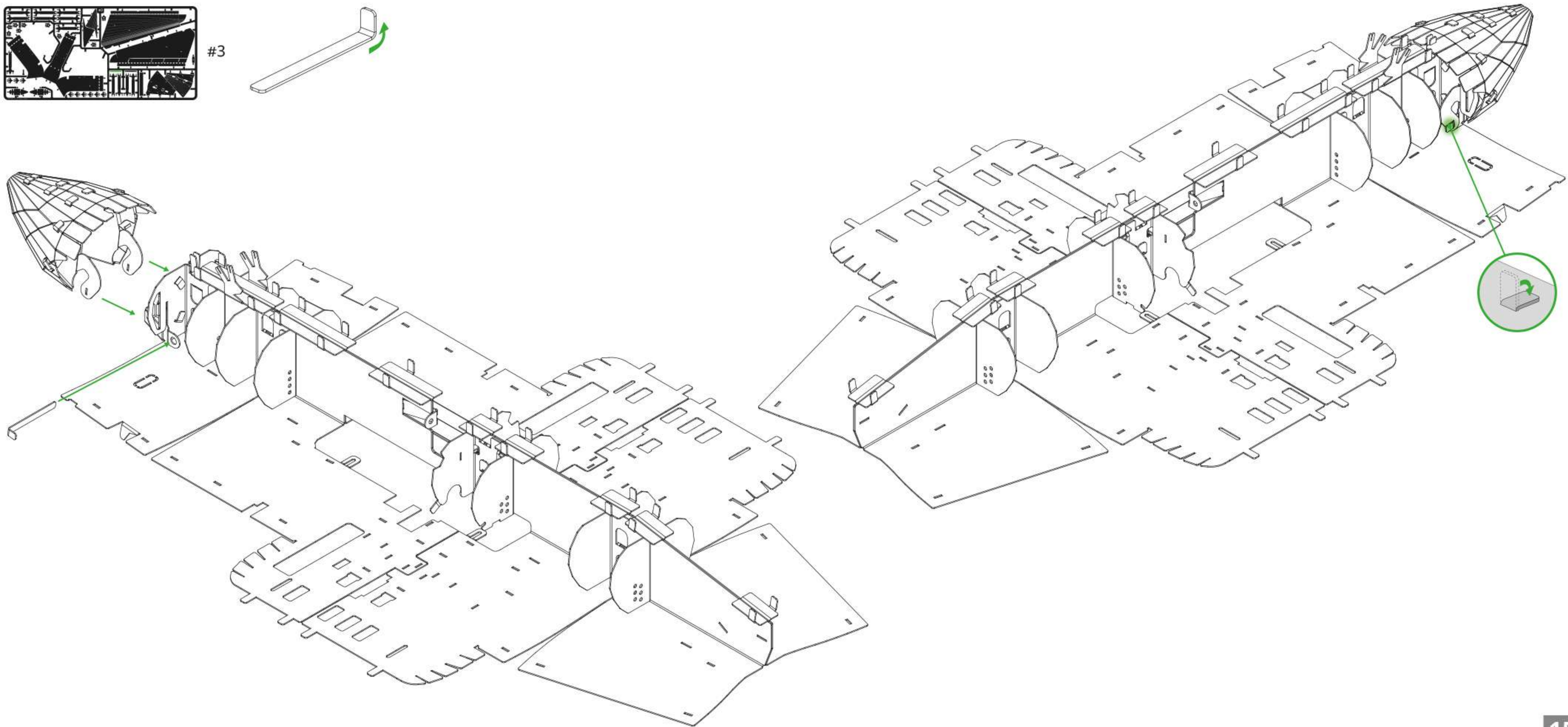
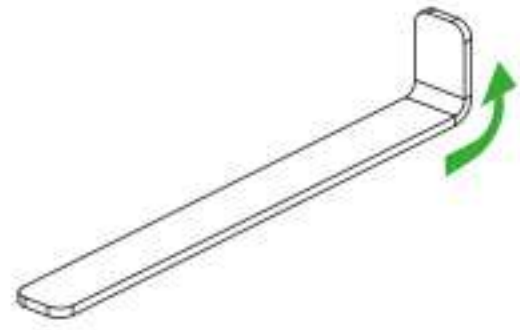

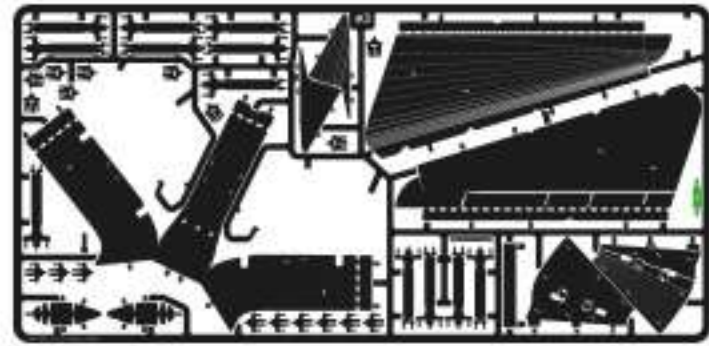

#3

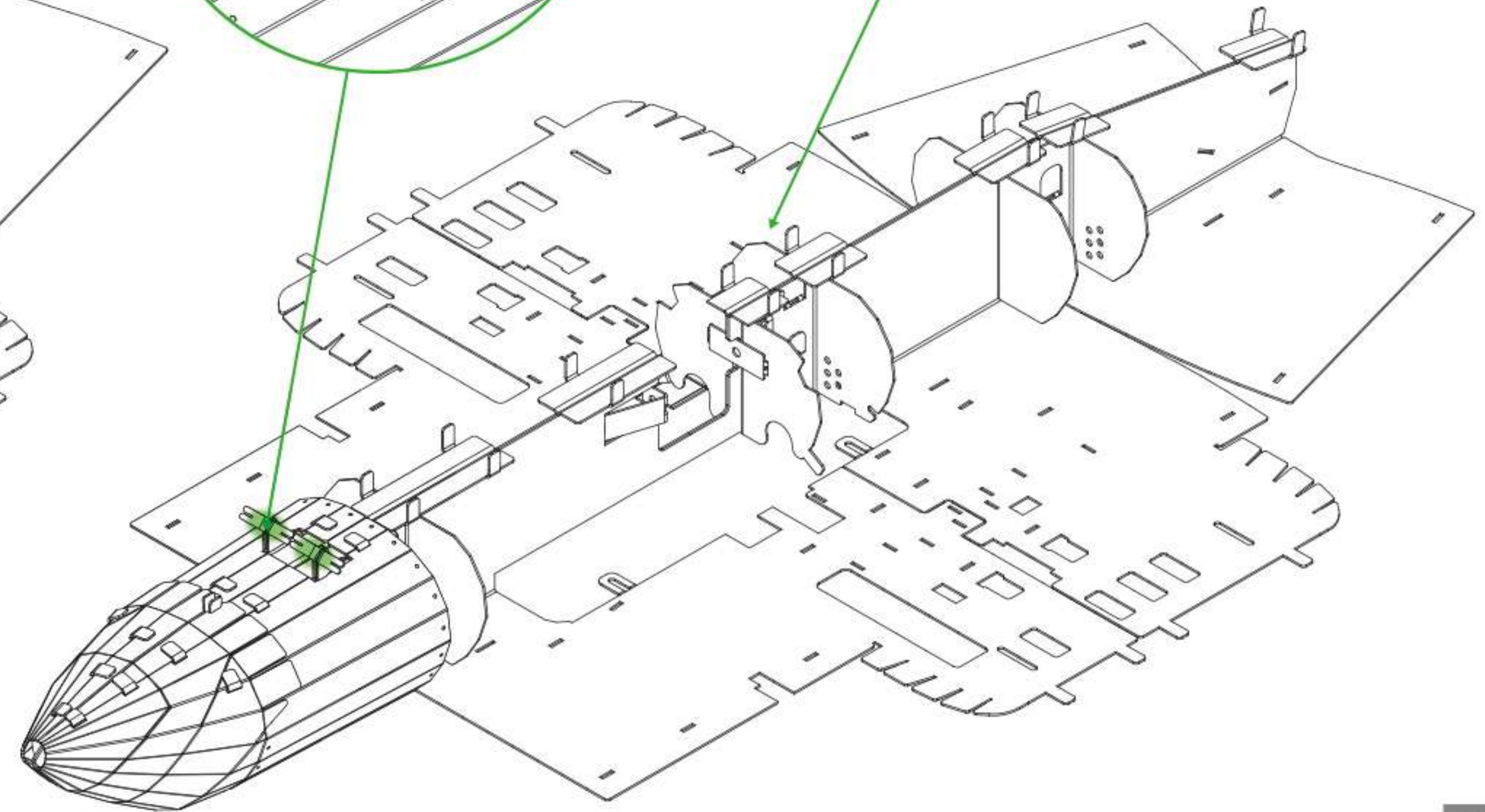
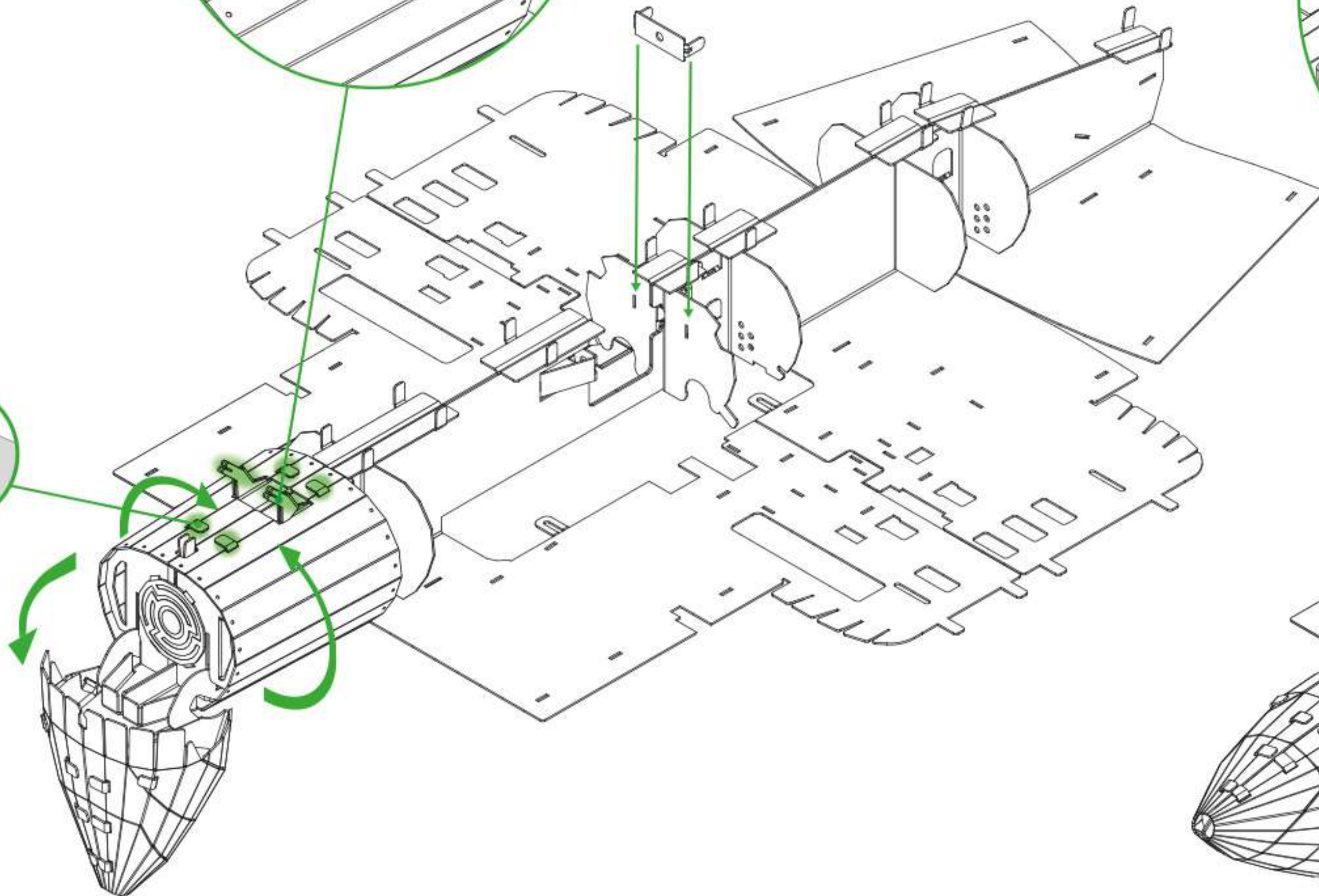
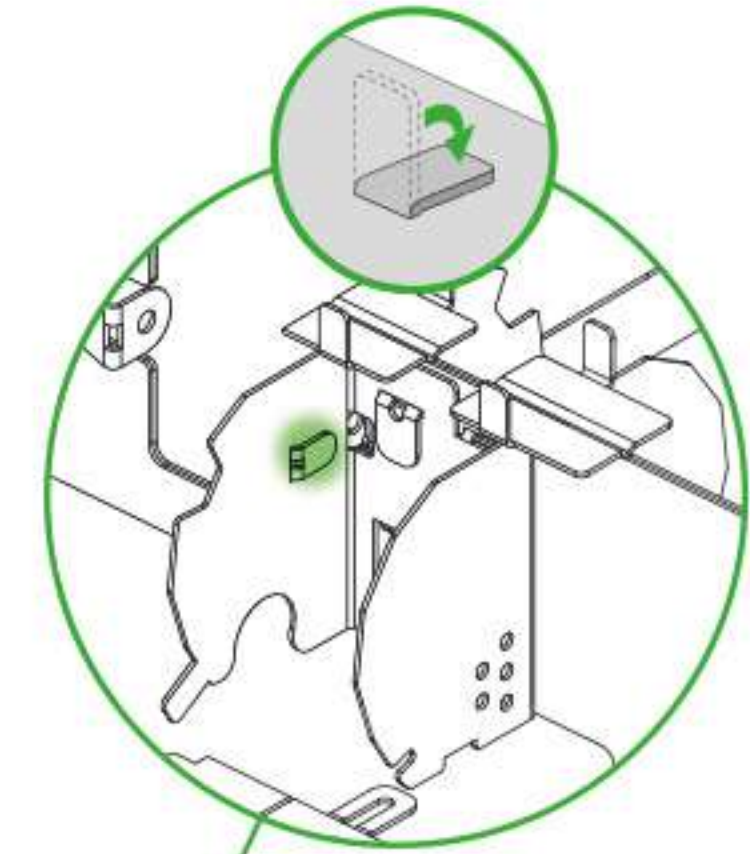
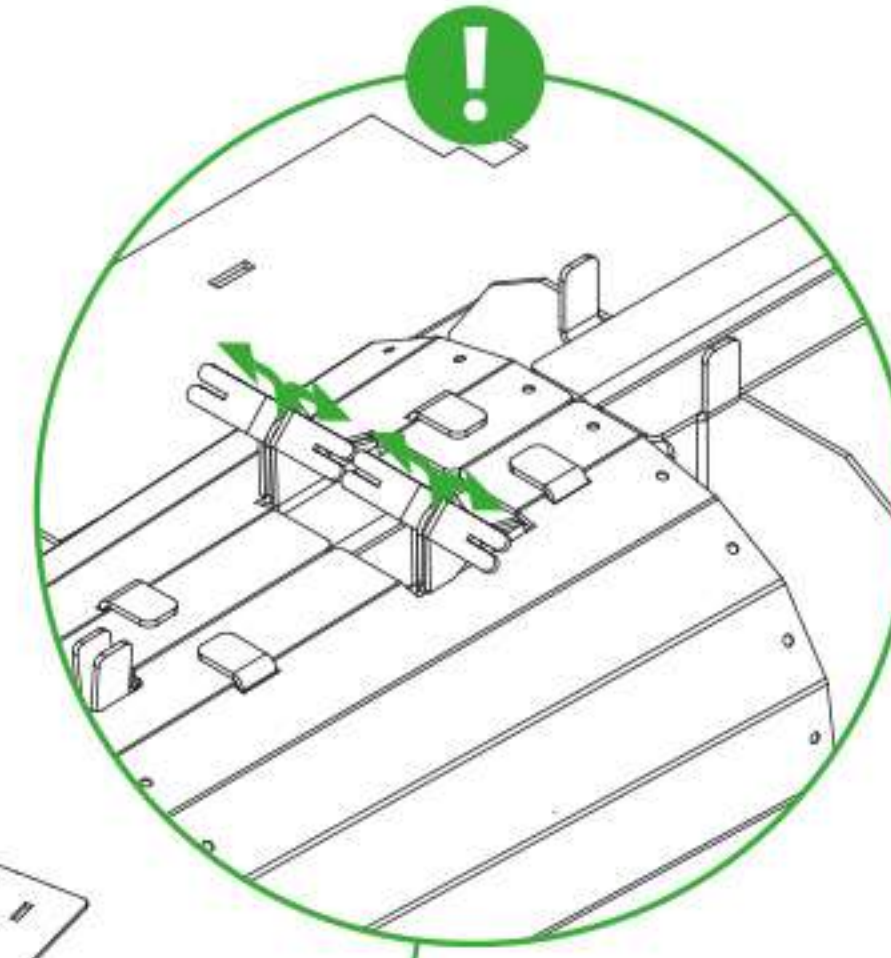
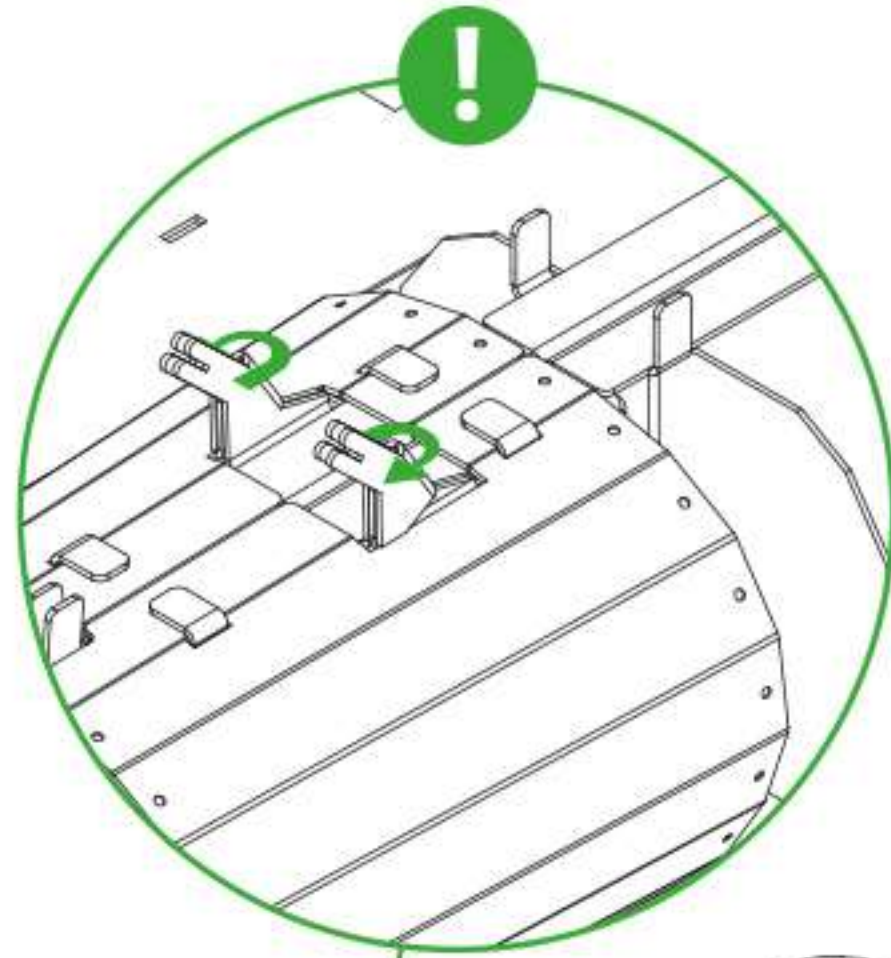
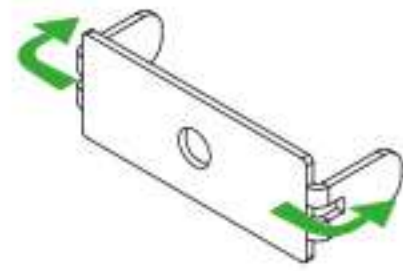

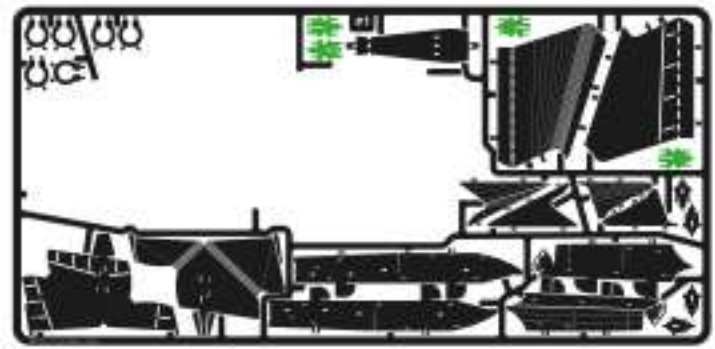

#1



G4



G5

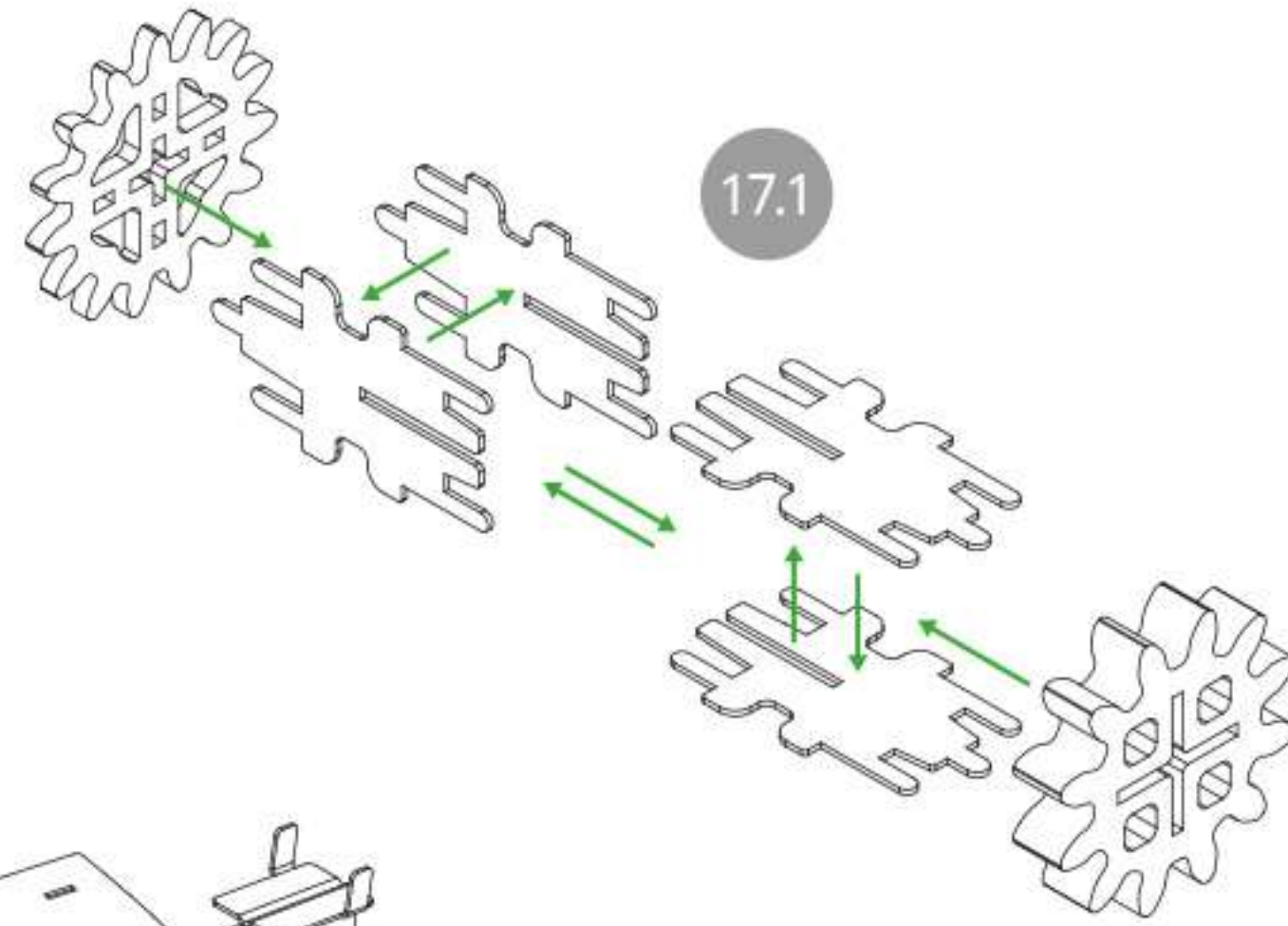

17.1

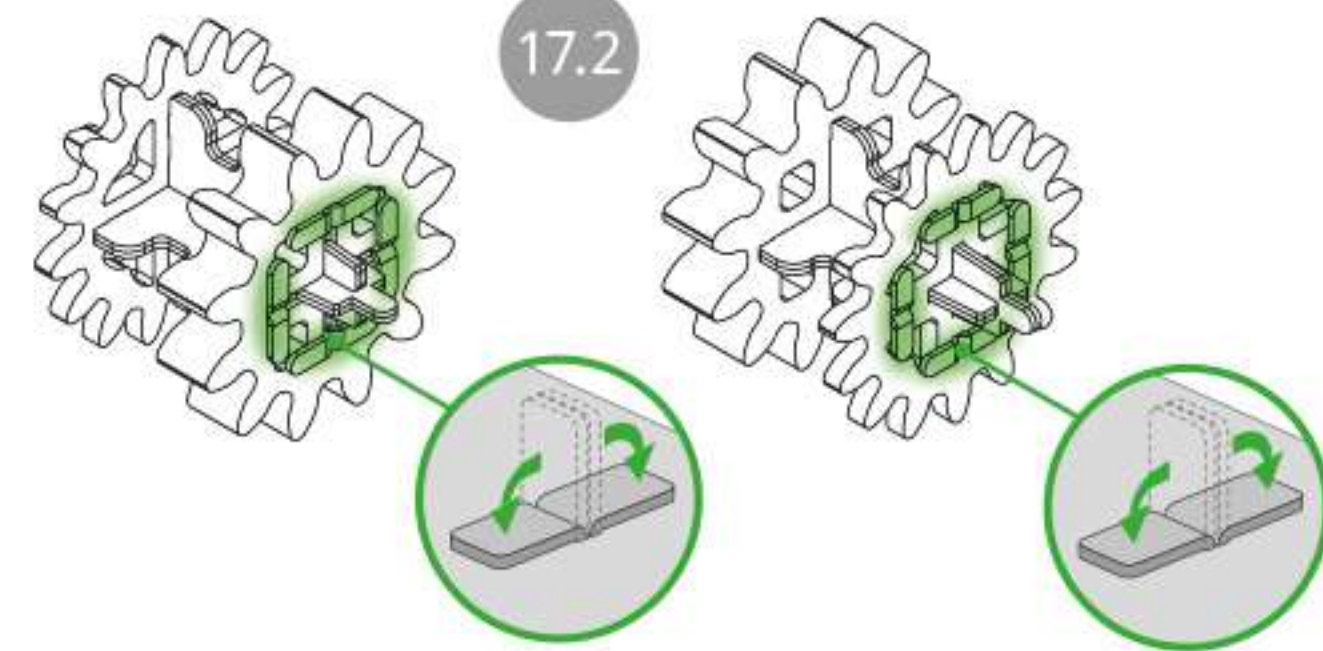

17.2

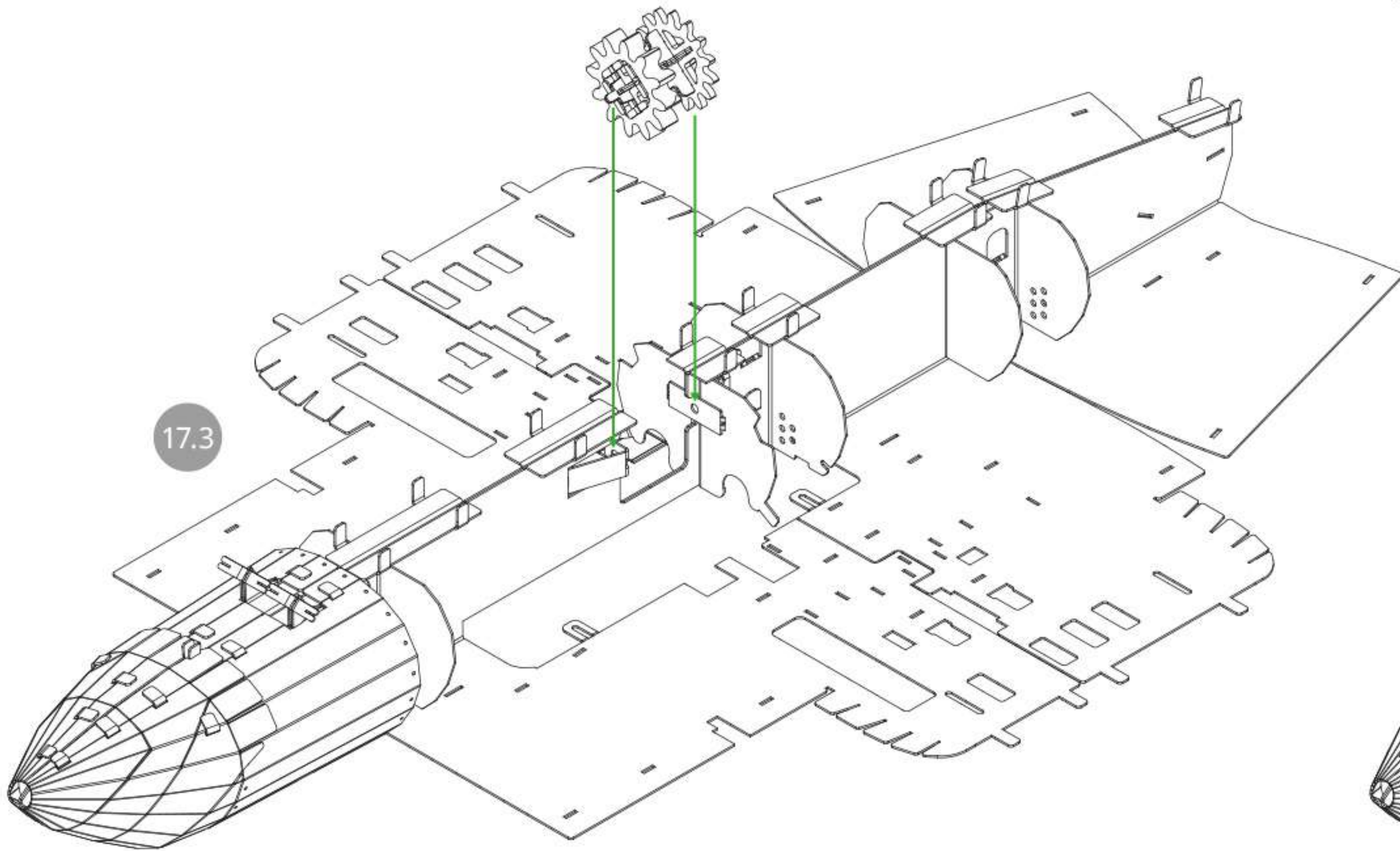

17.3

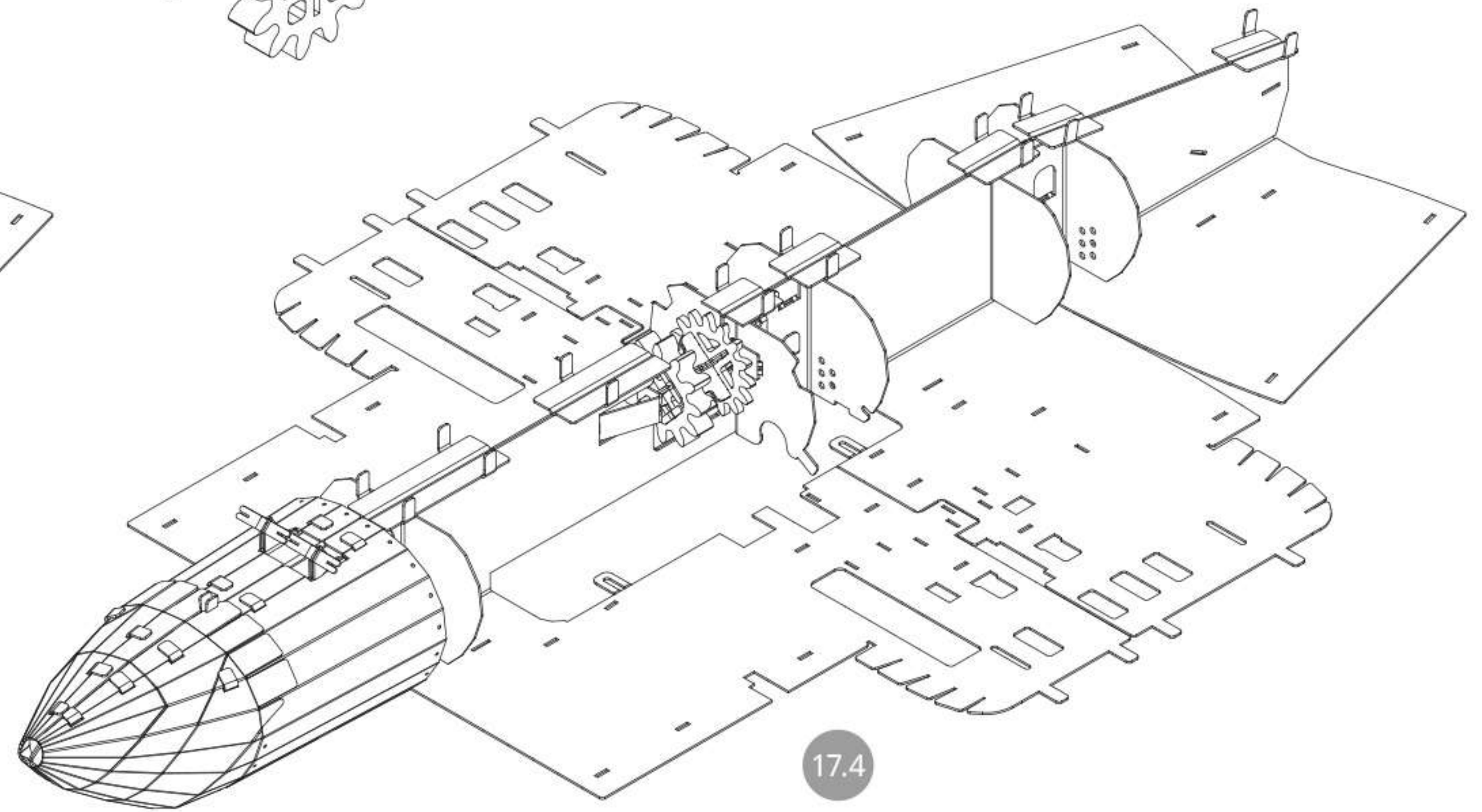

17.4

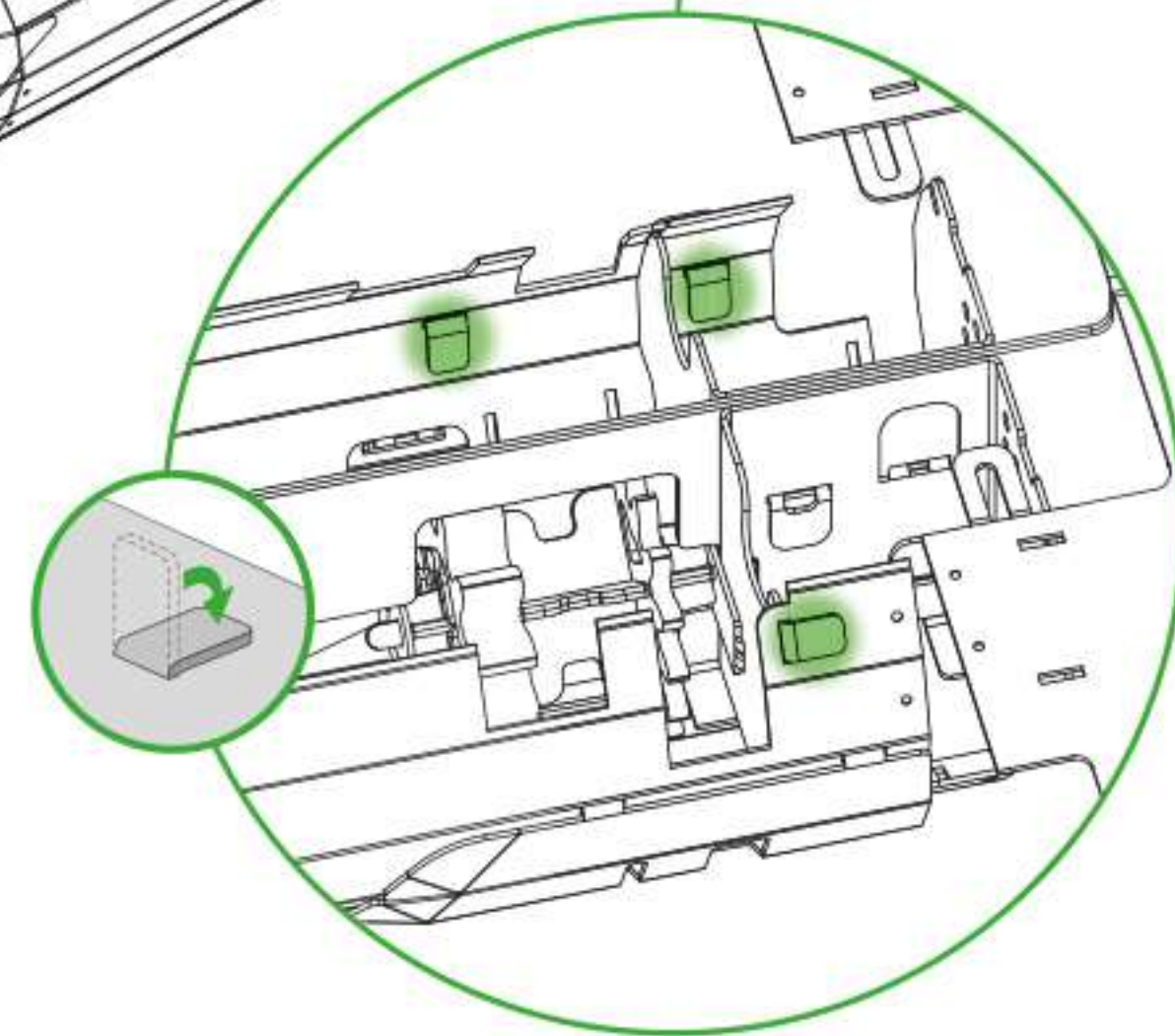
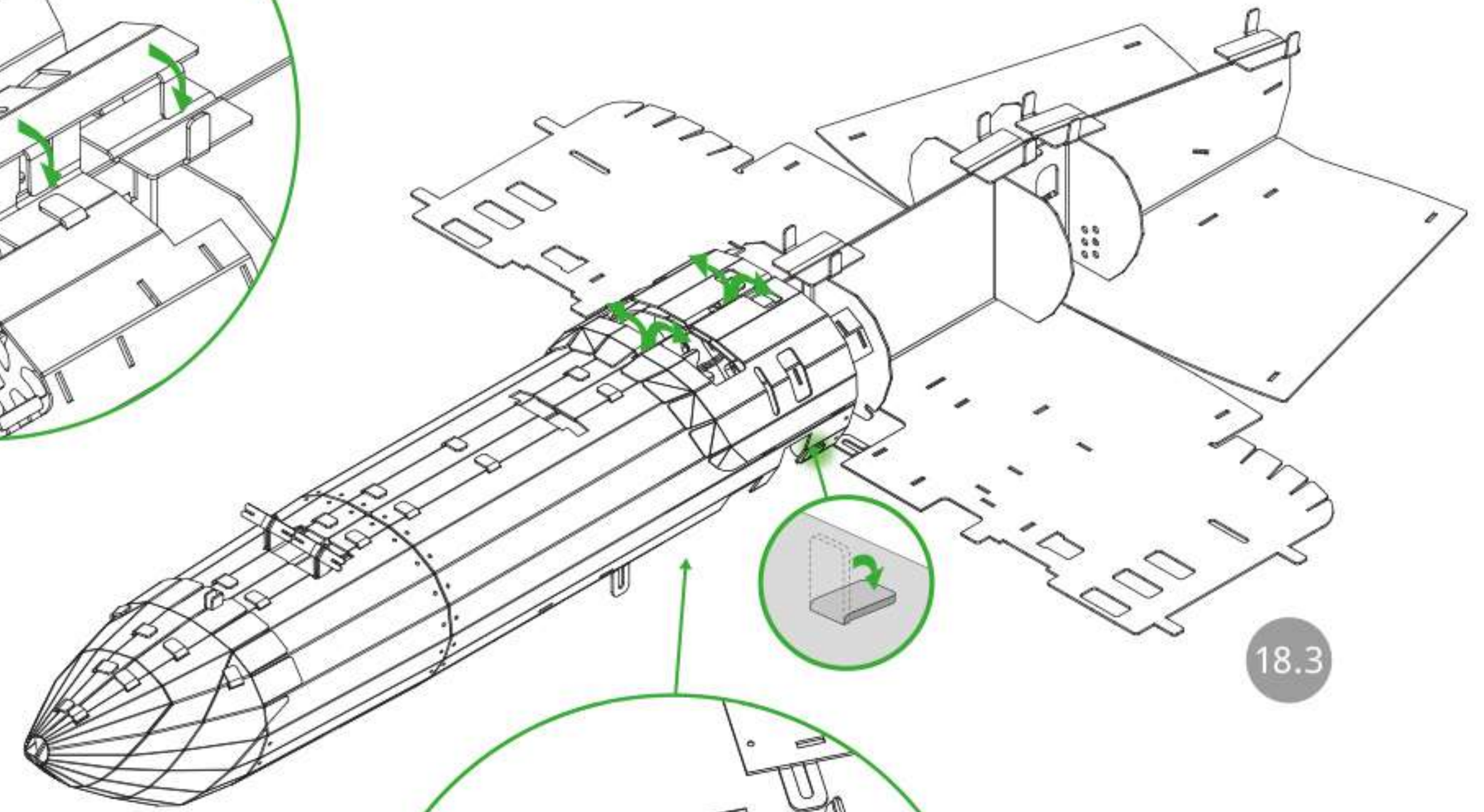
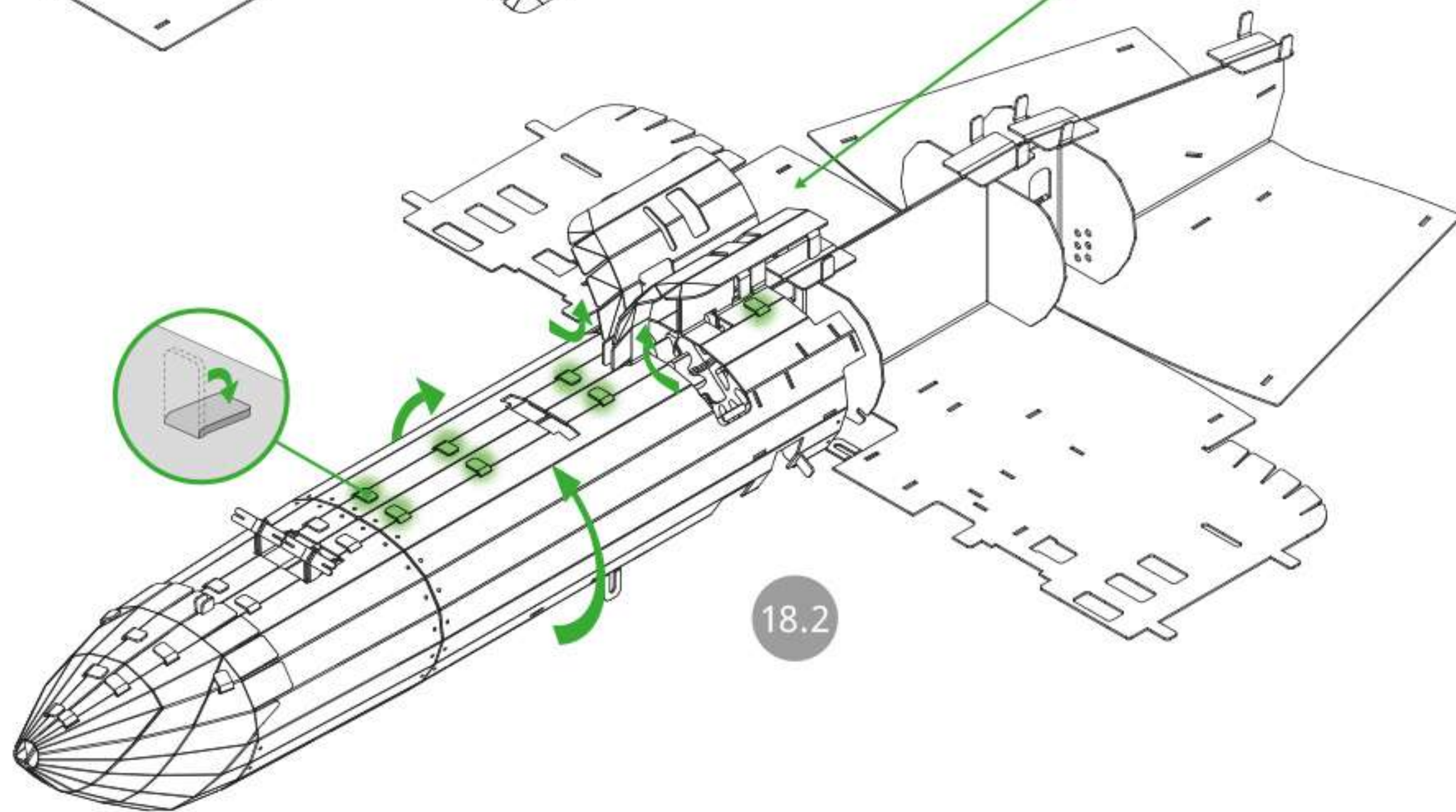
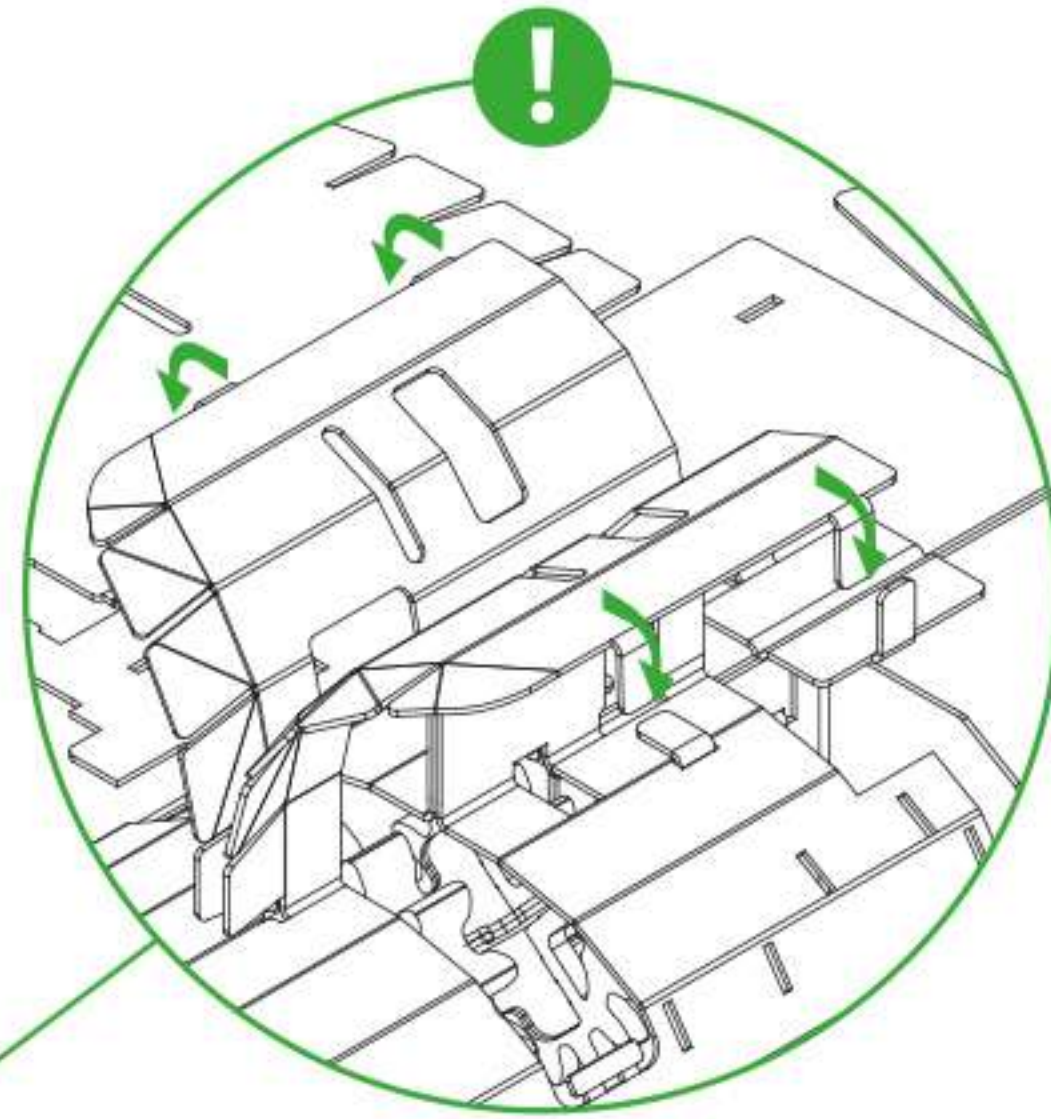
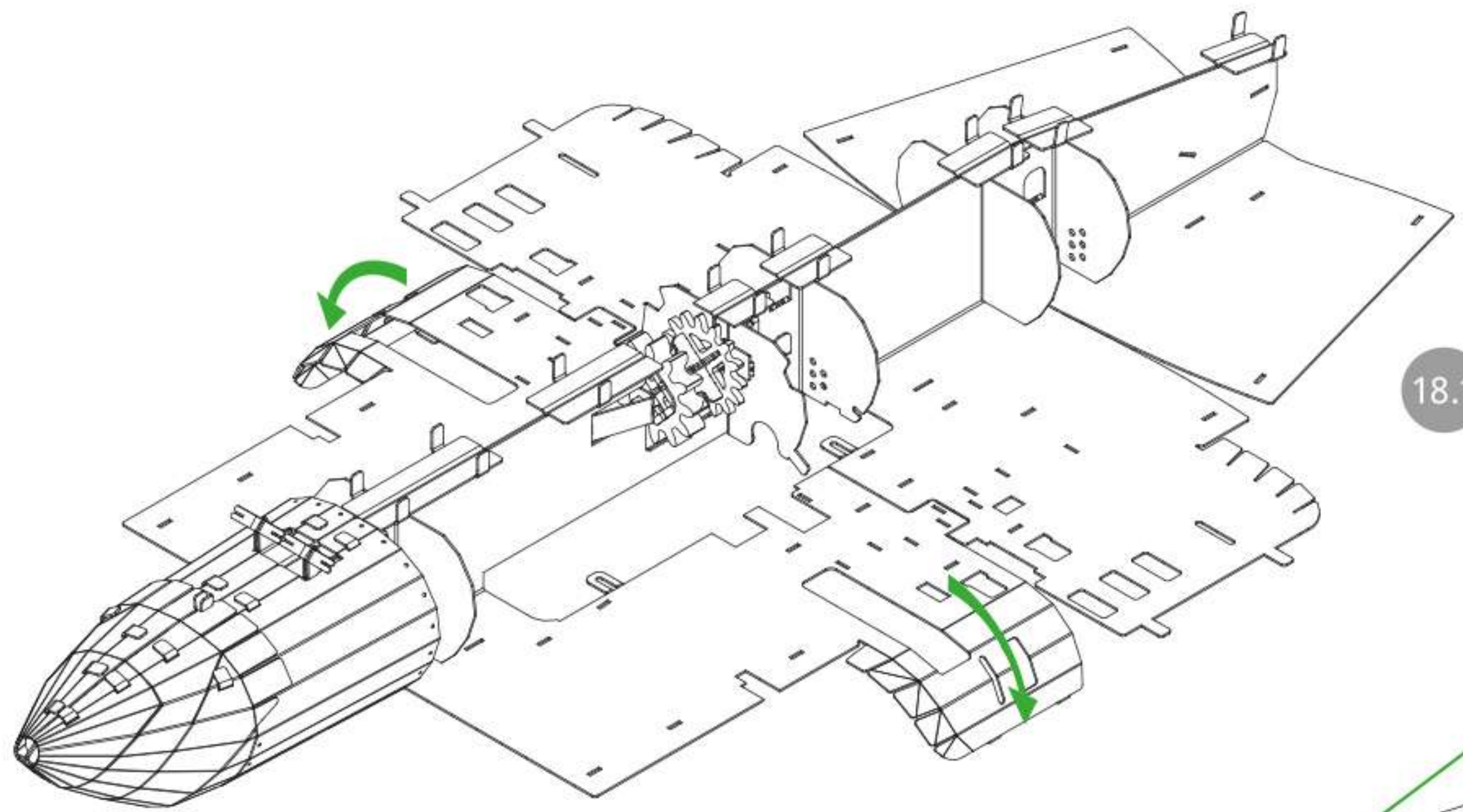

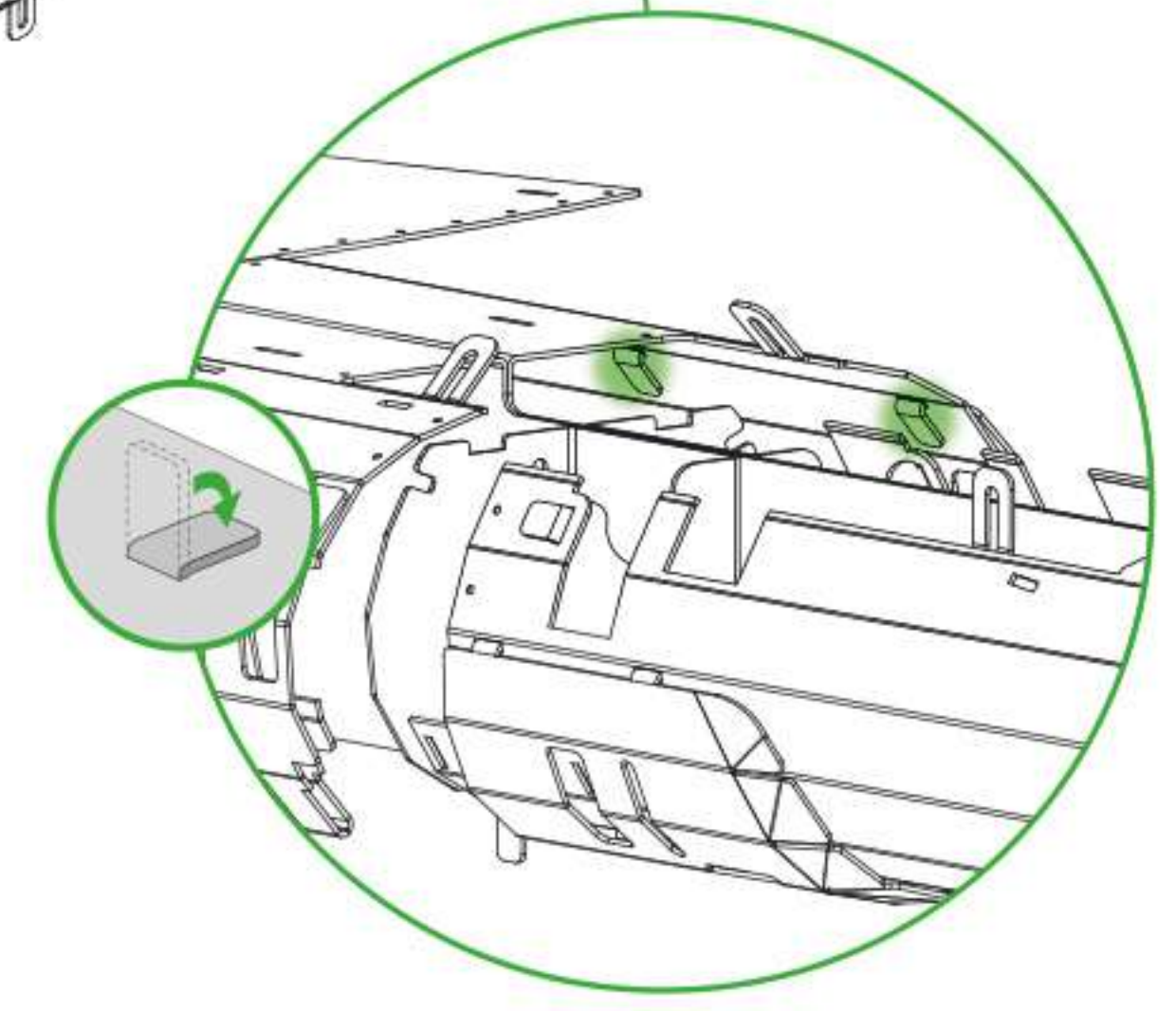
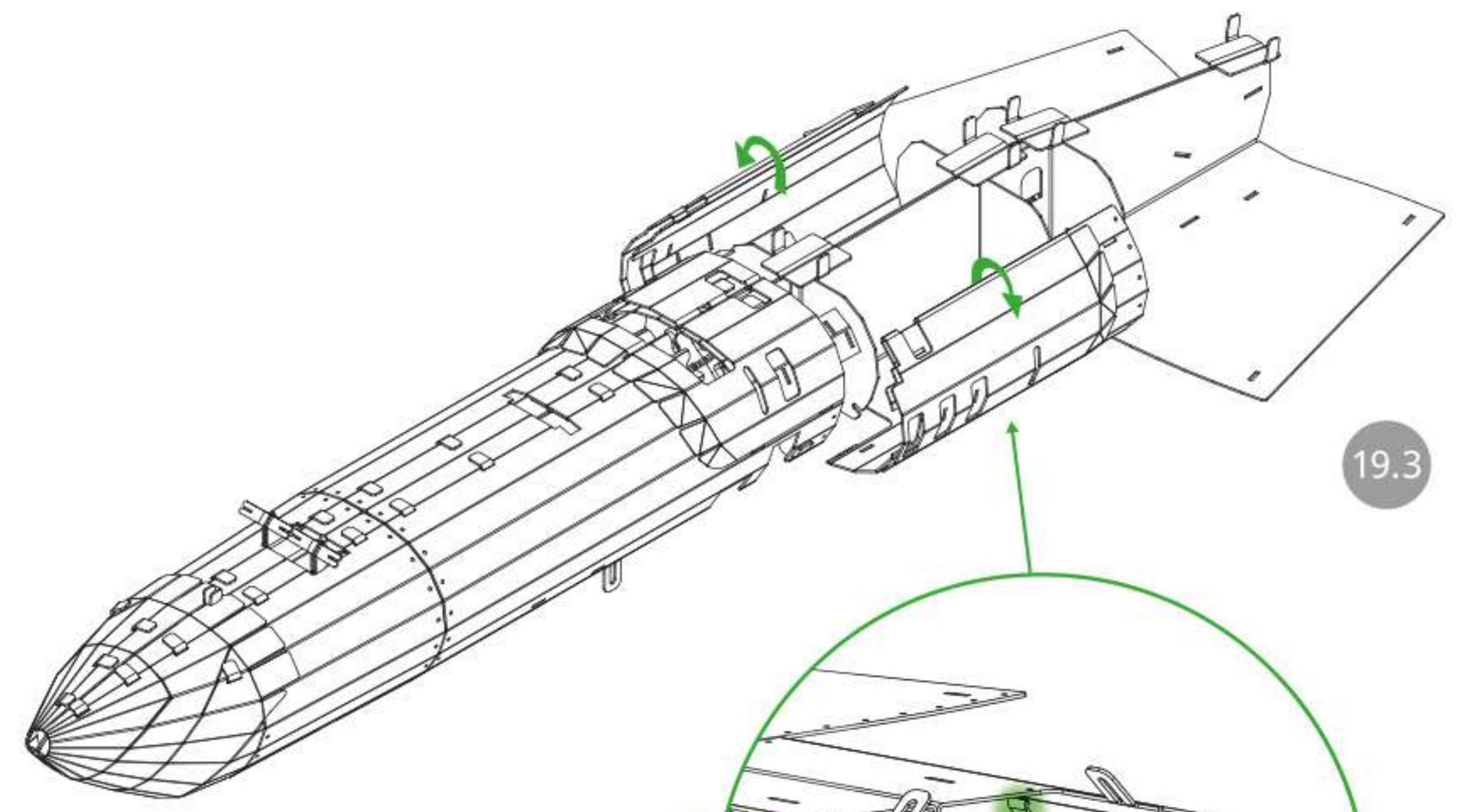
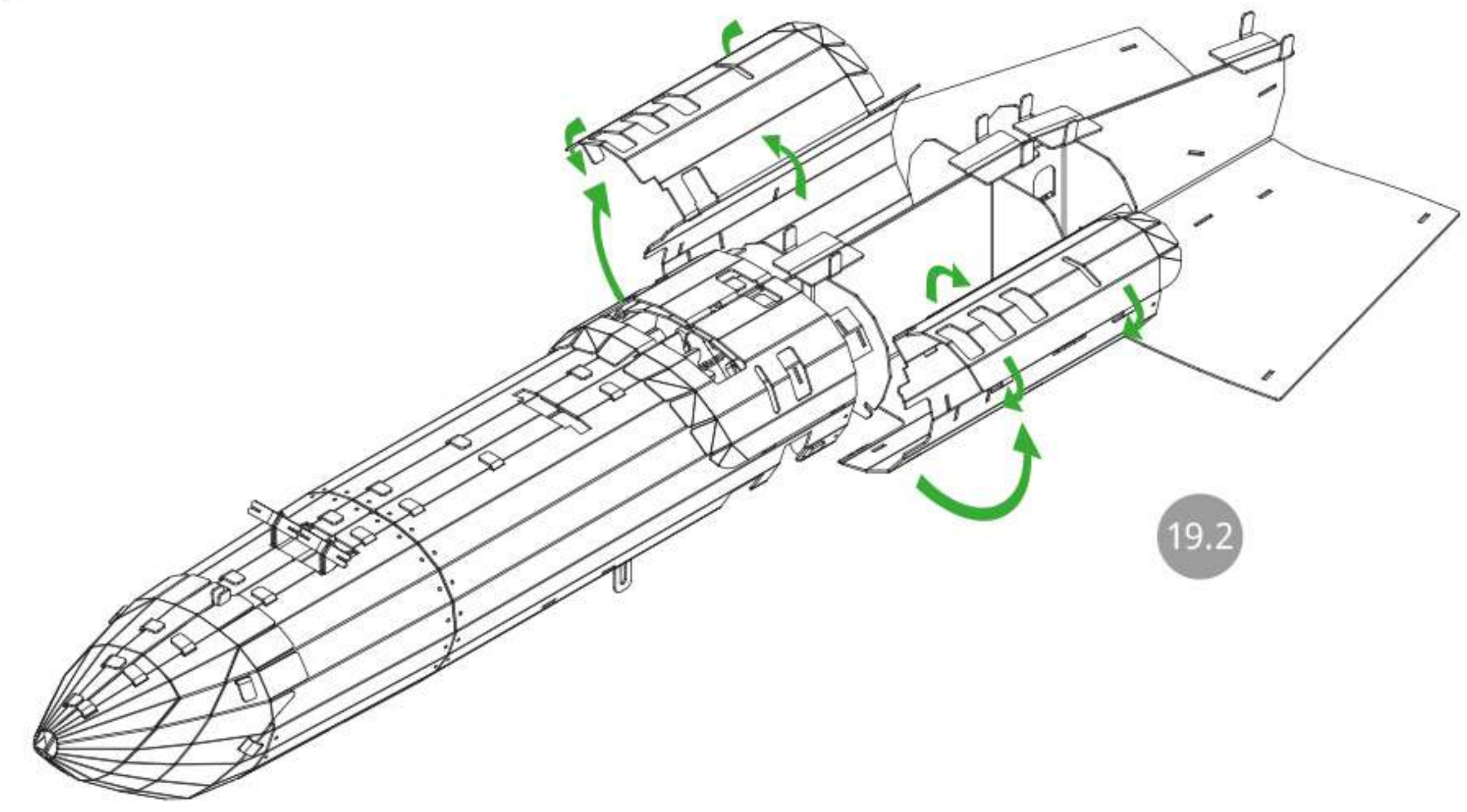
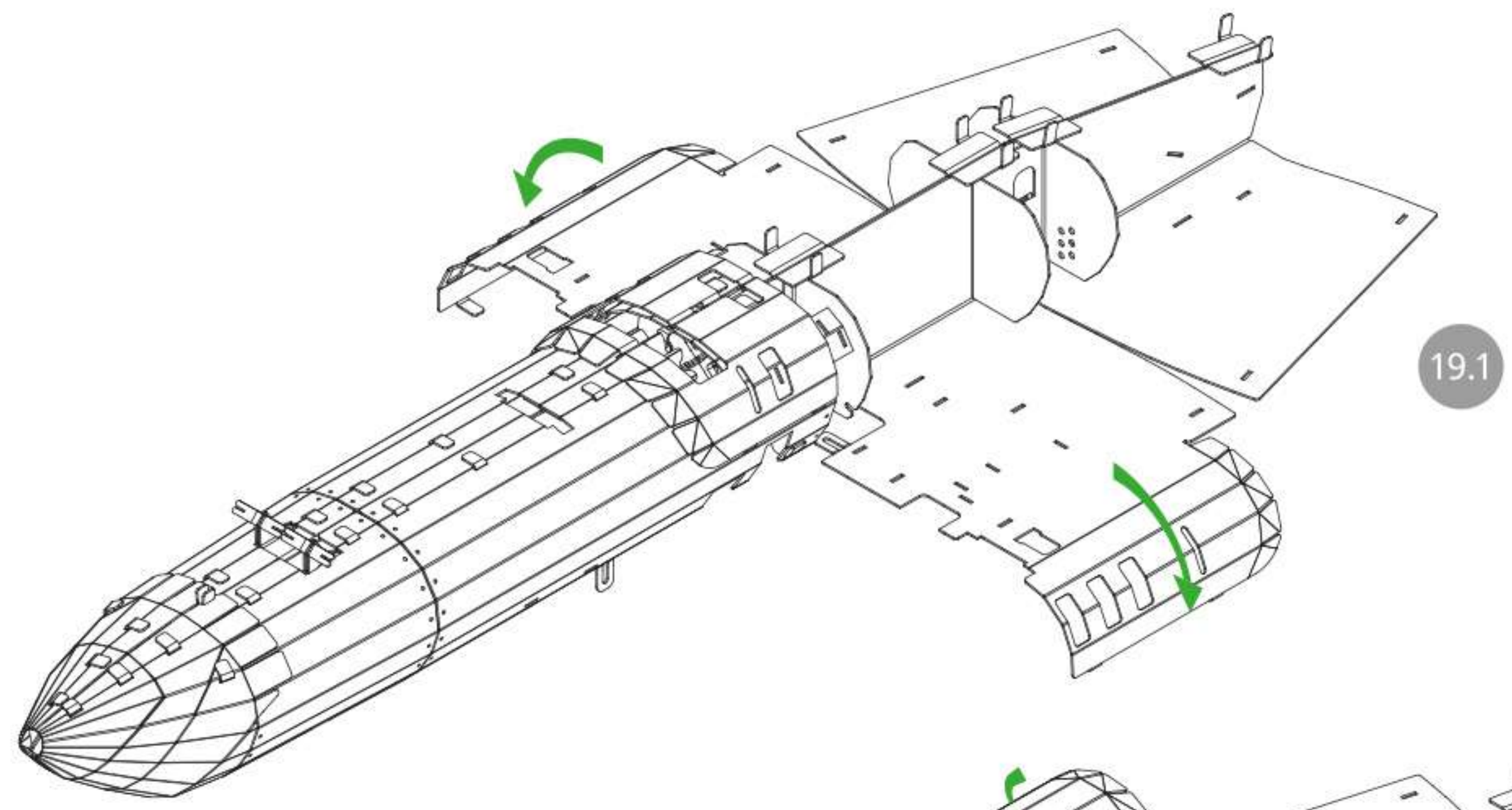

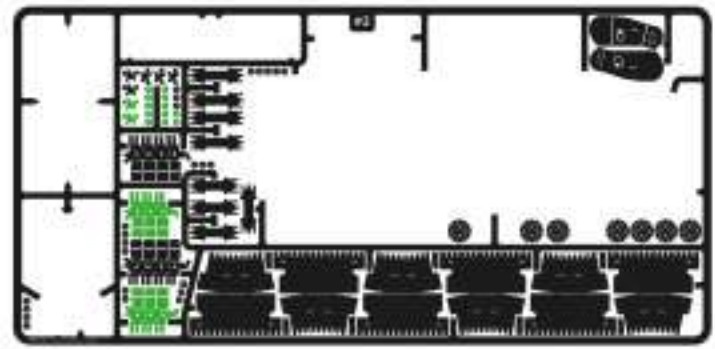

x12
wheels

#2

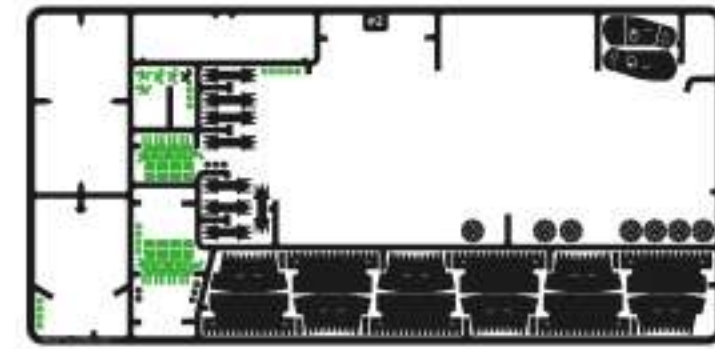
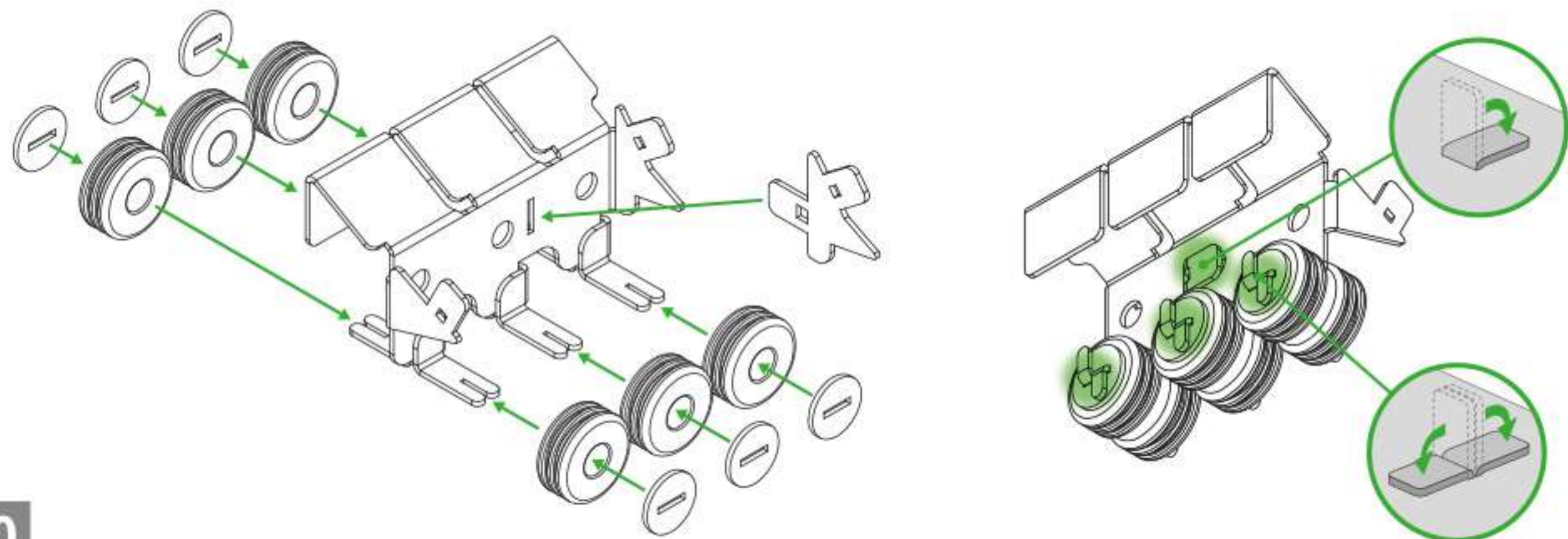
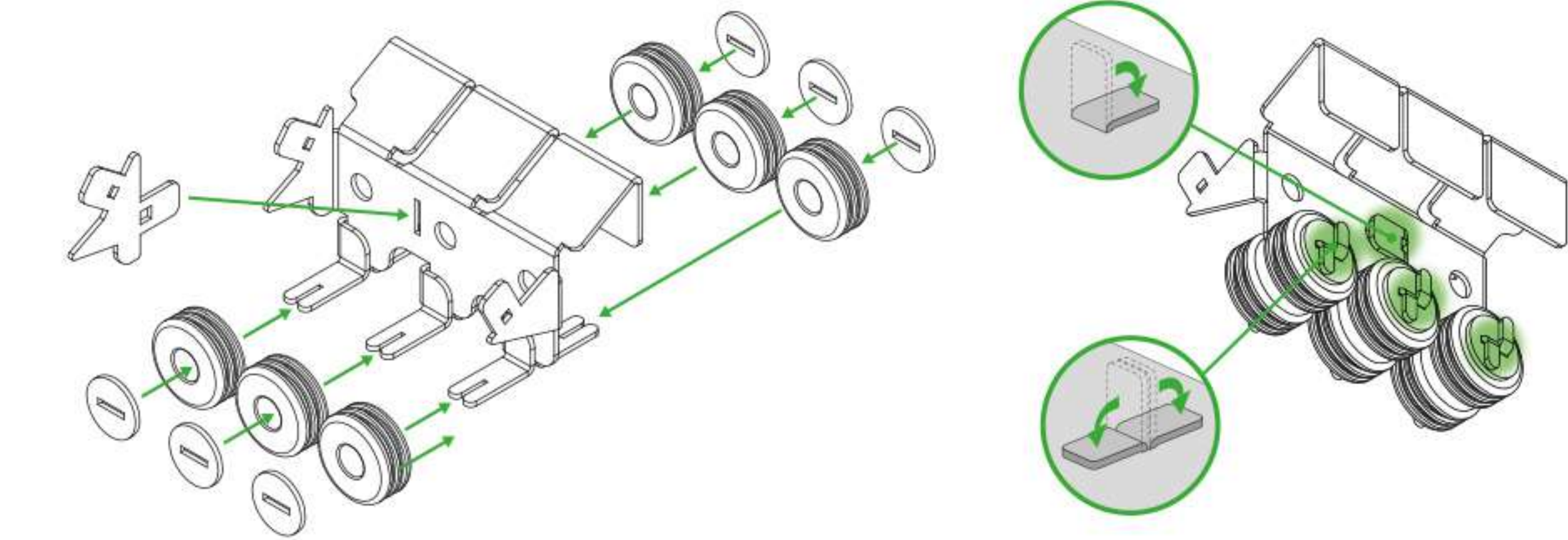
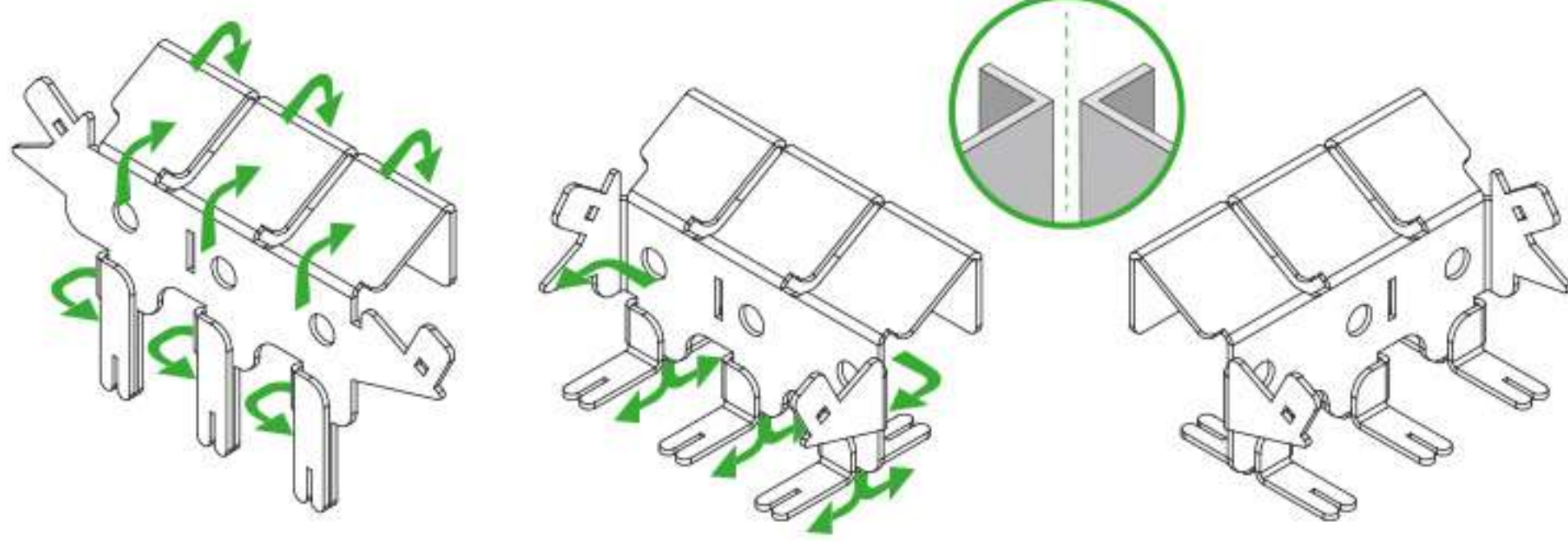

x16
wheels

#2

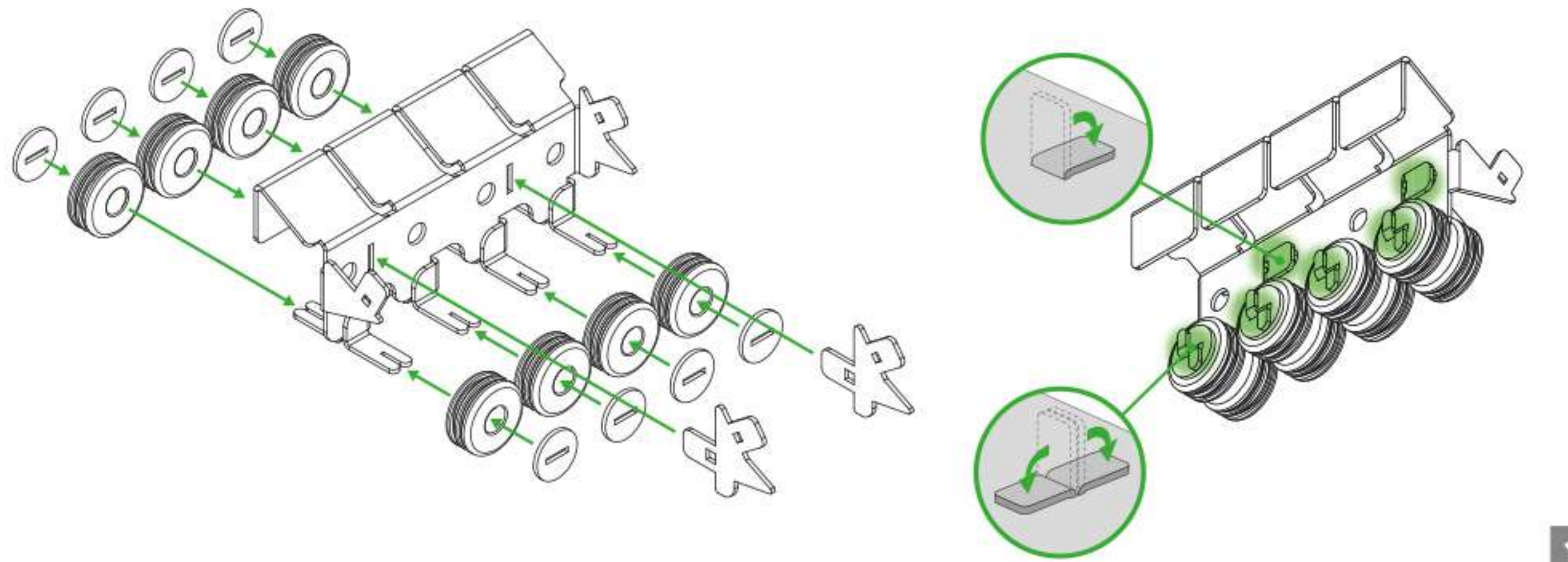
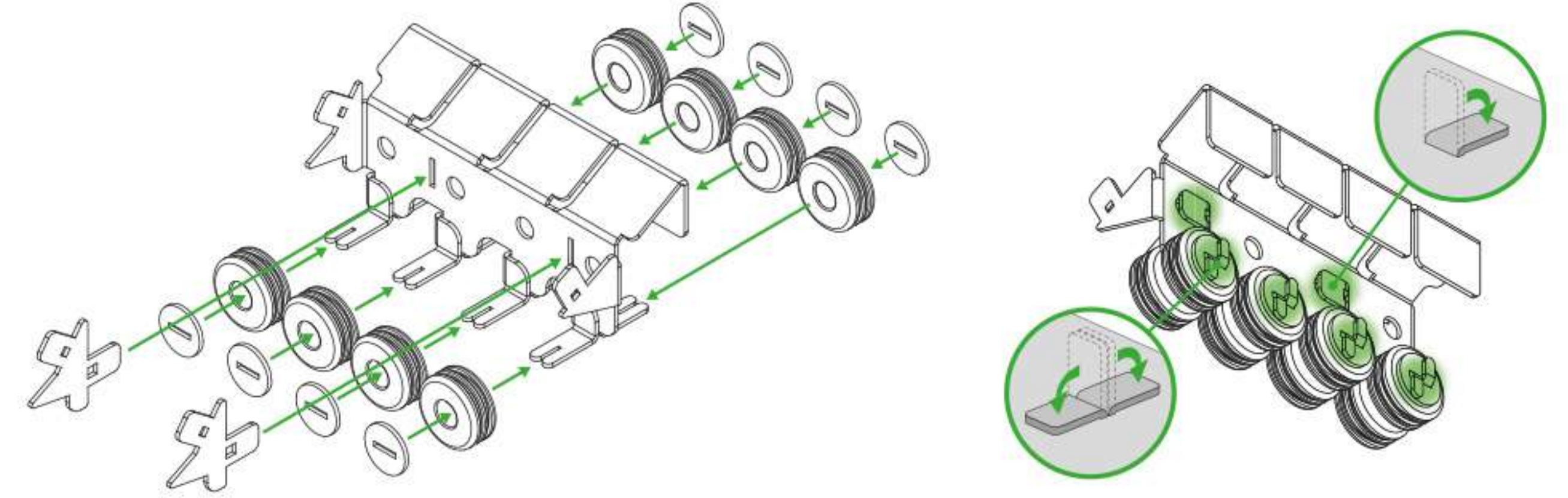
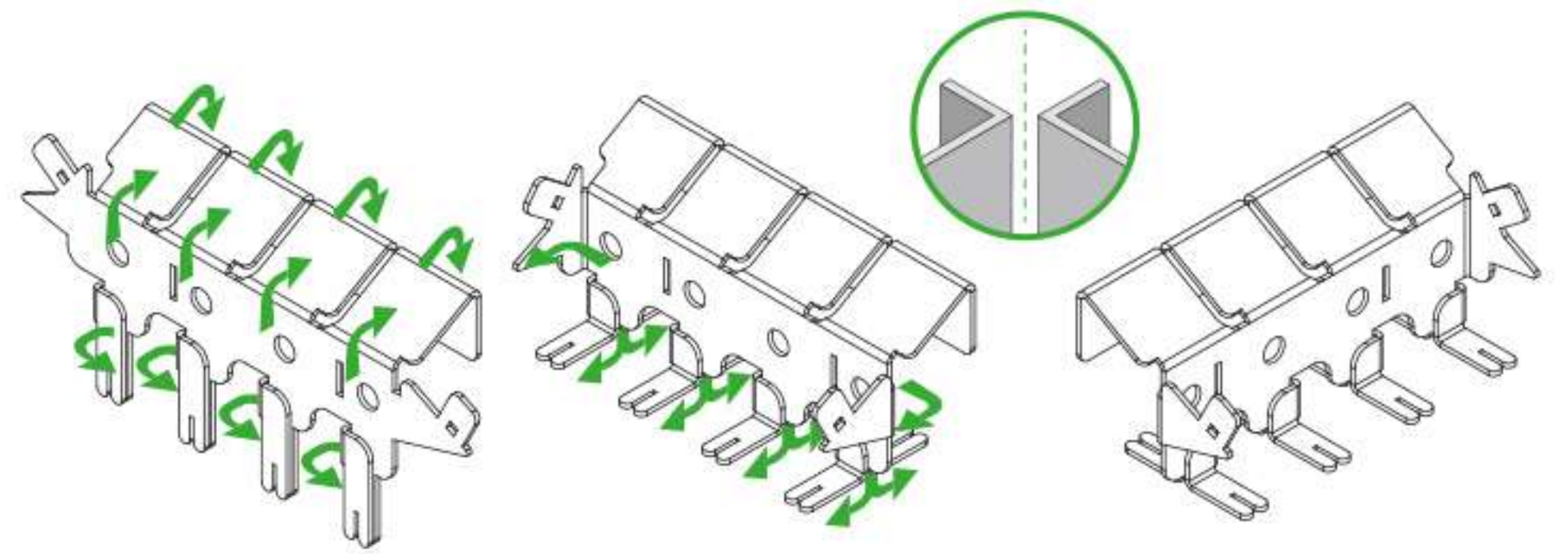

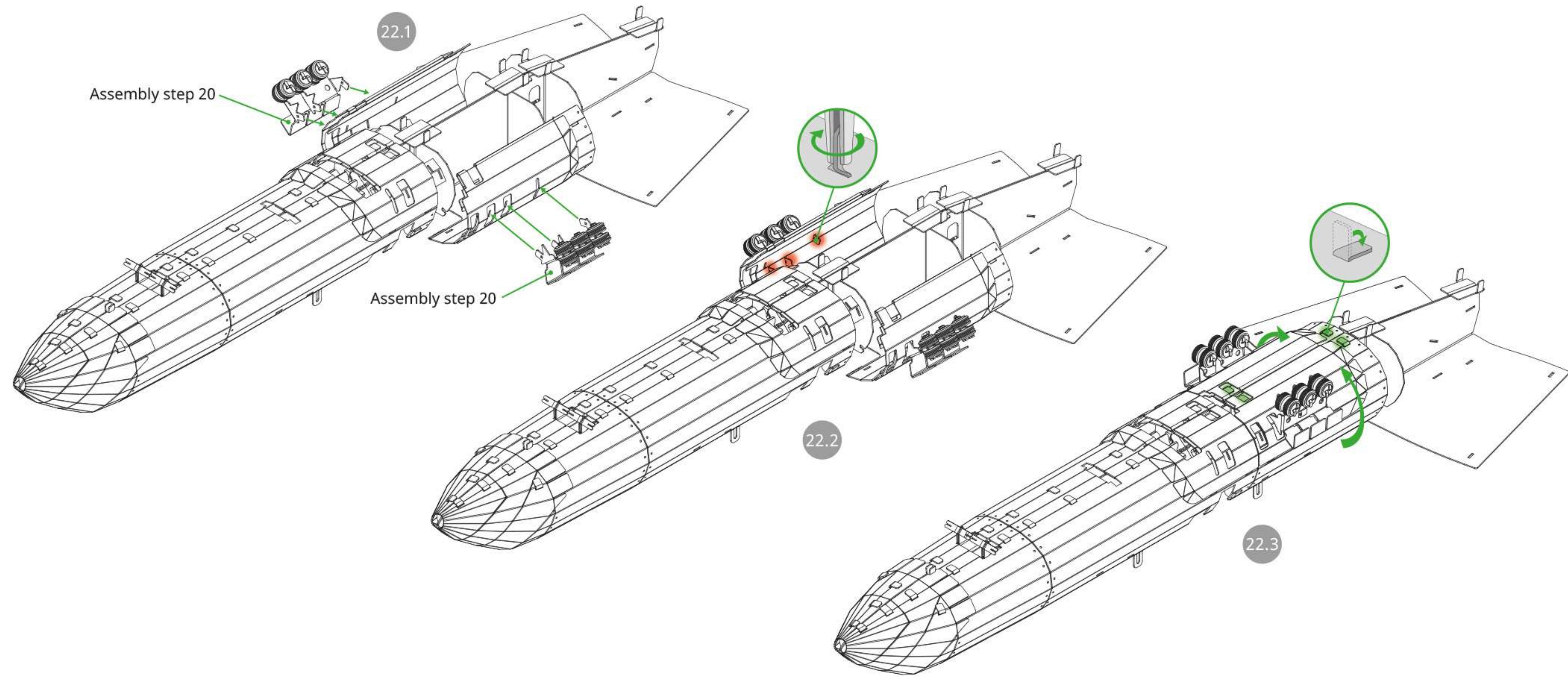

22.1

Assembly step 20

Assembly step 20

22.2

22.3

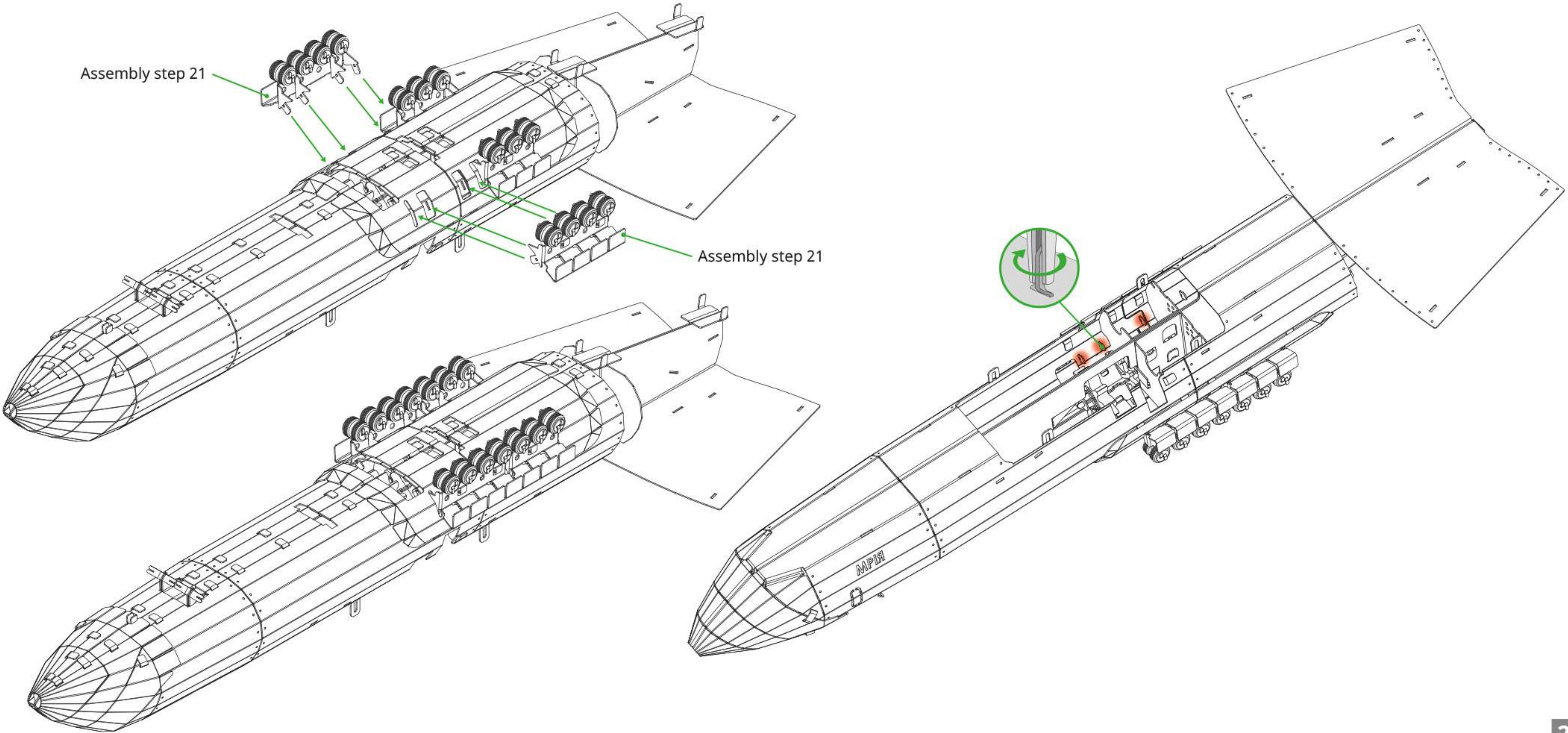

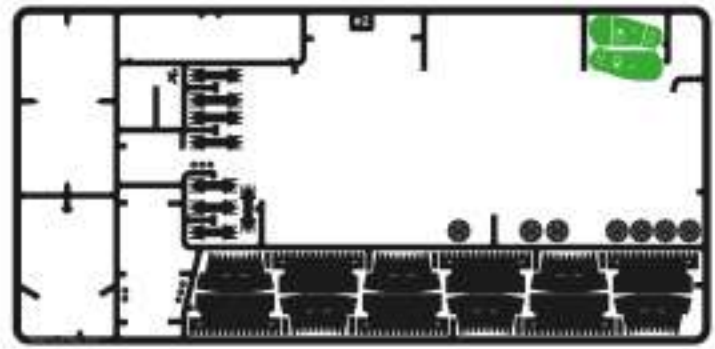

#2

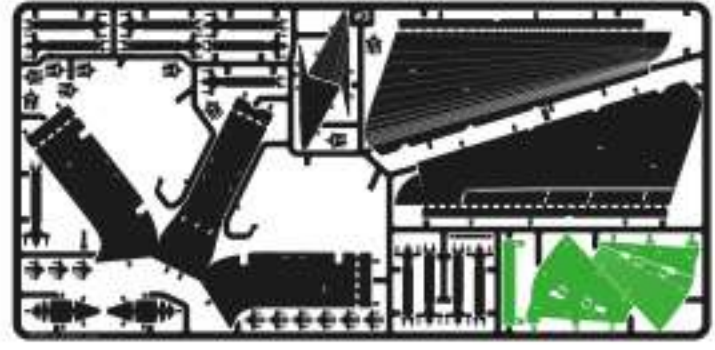
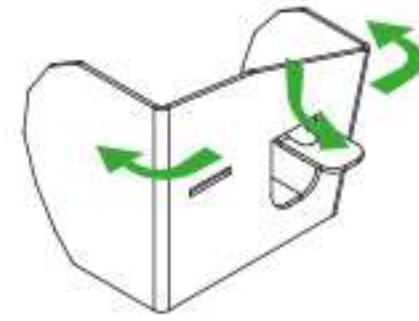

#3

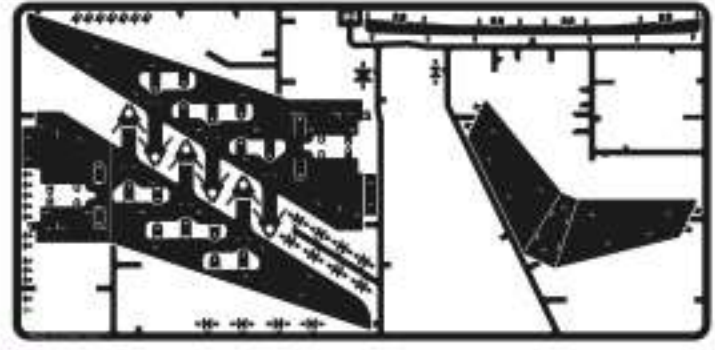
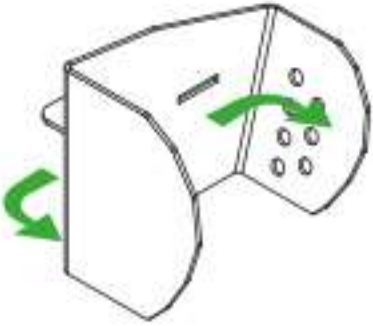

#4

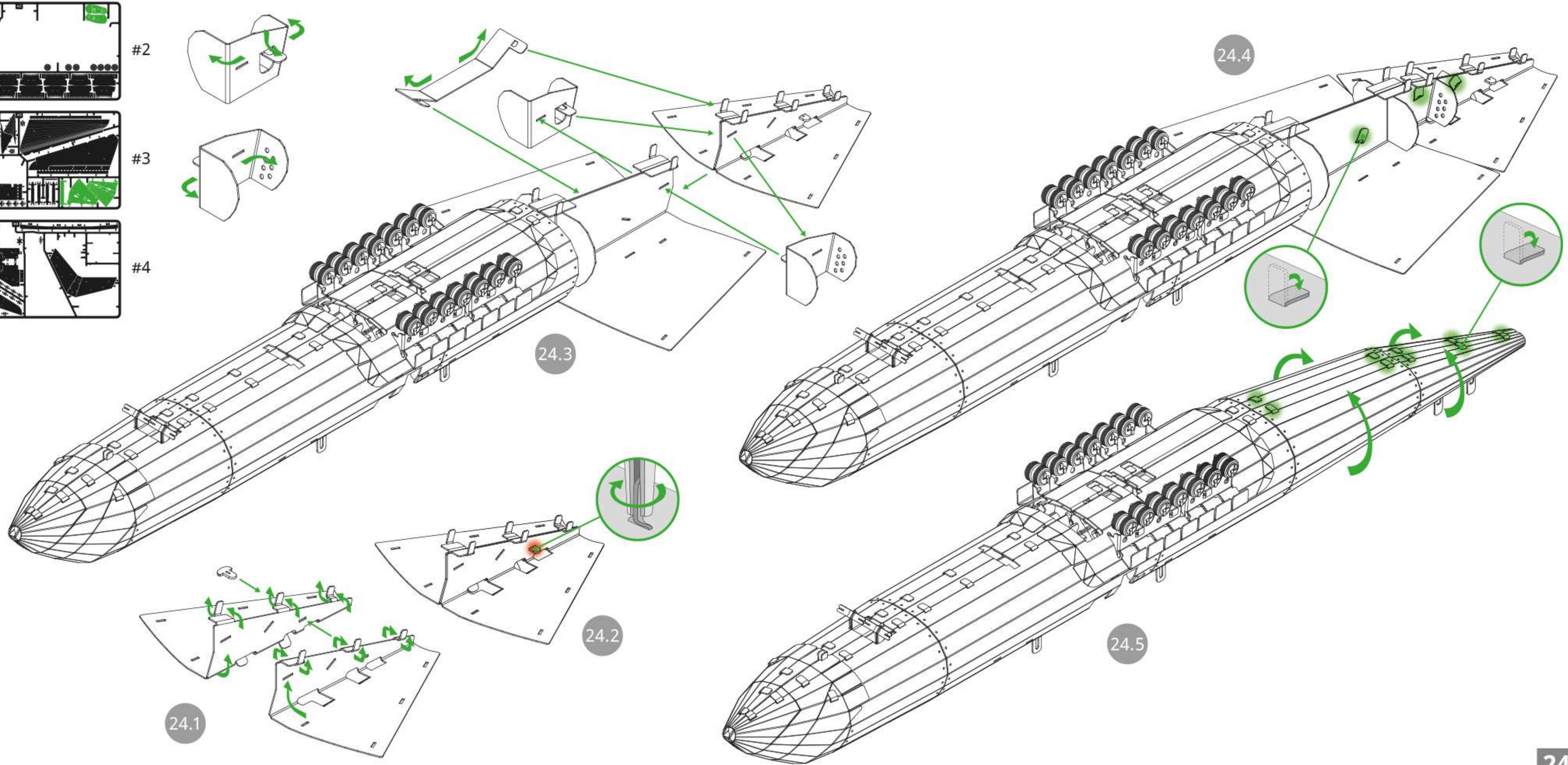

24.1

24.2

24.3

24.4

24.5

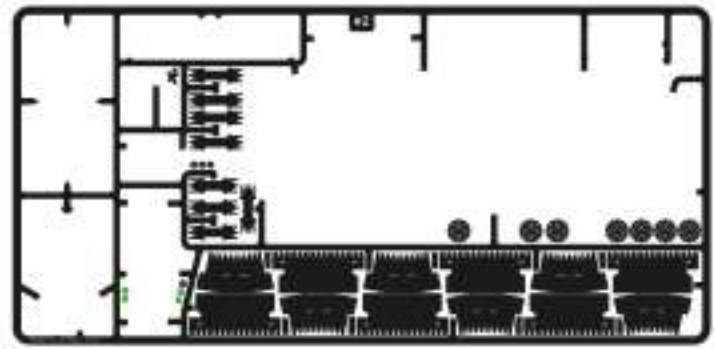

#2

 ×4
wheels

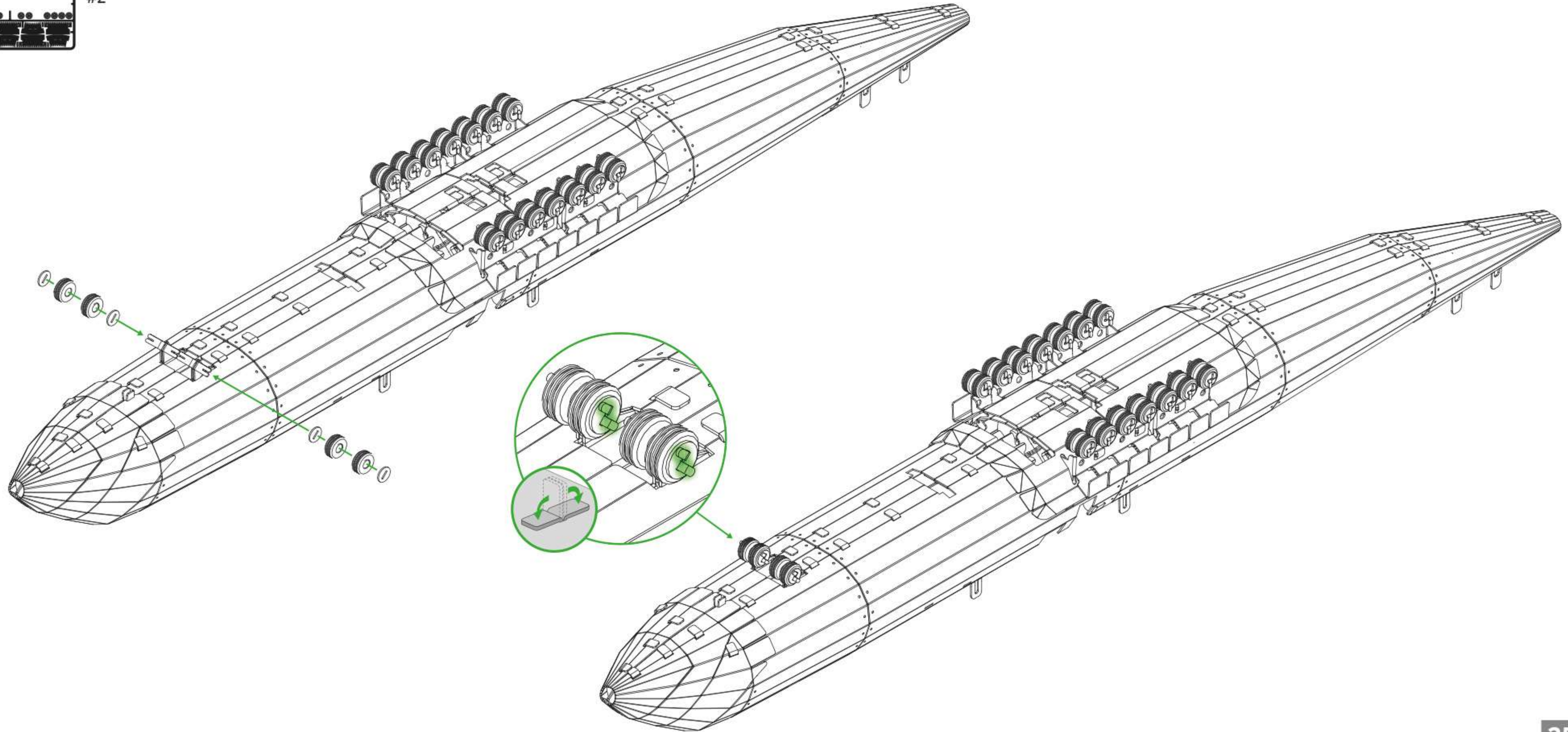

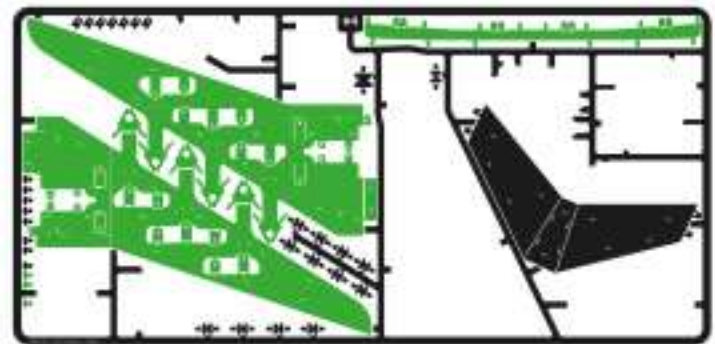

#4

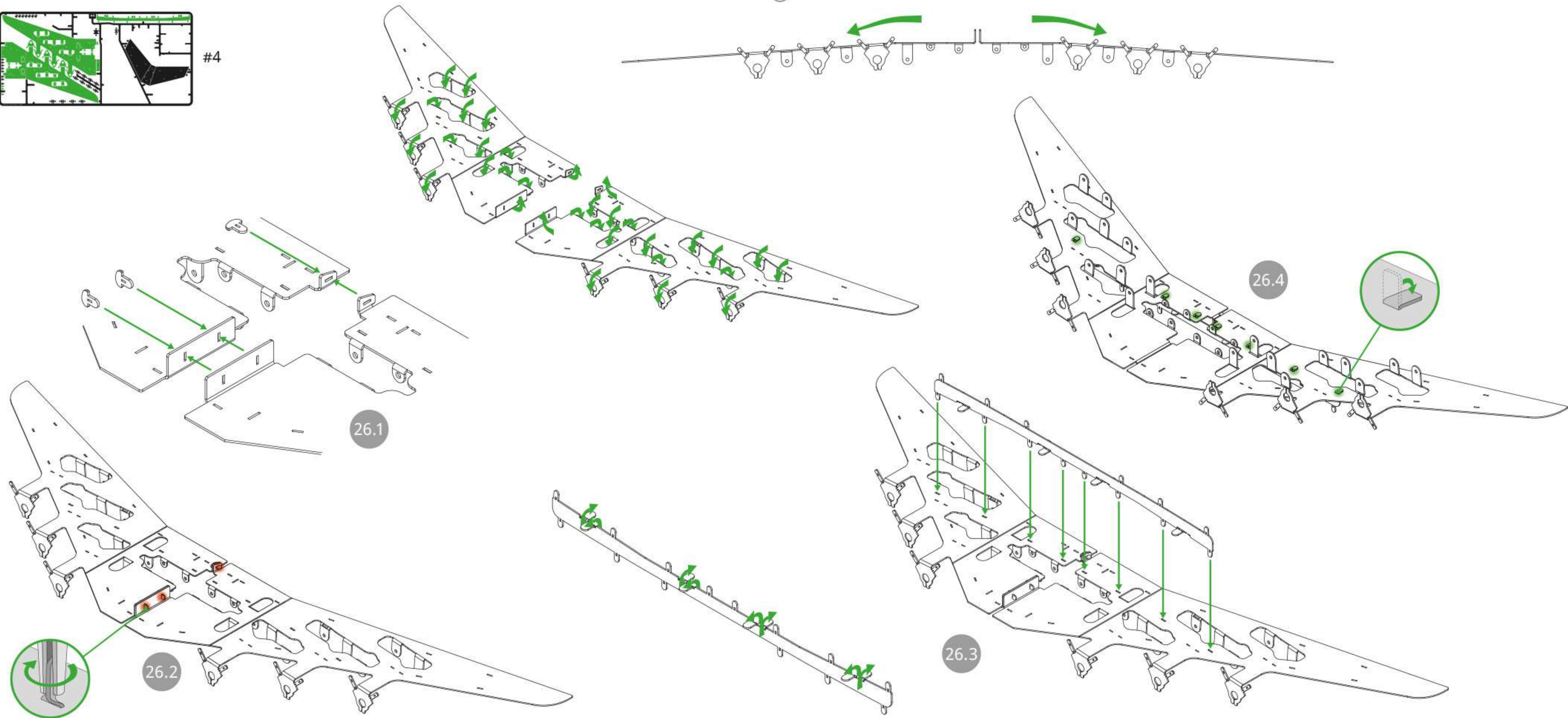

26.1

26.2

26.3

26.4

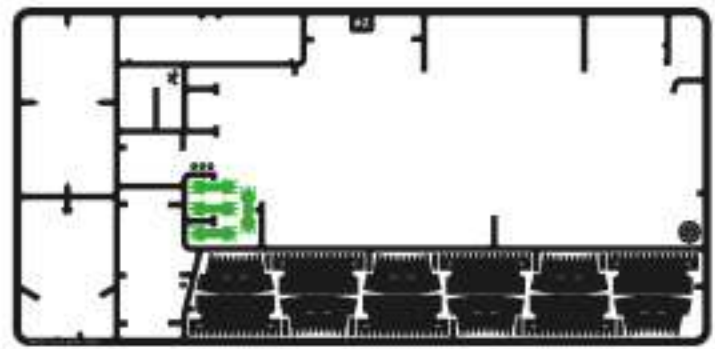

#2

 x4
G8

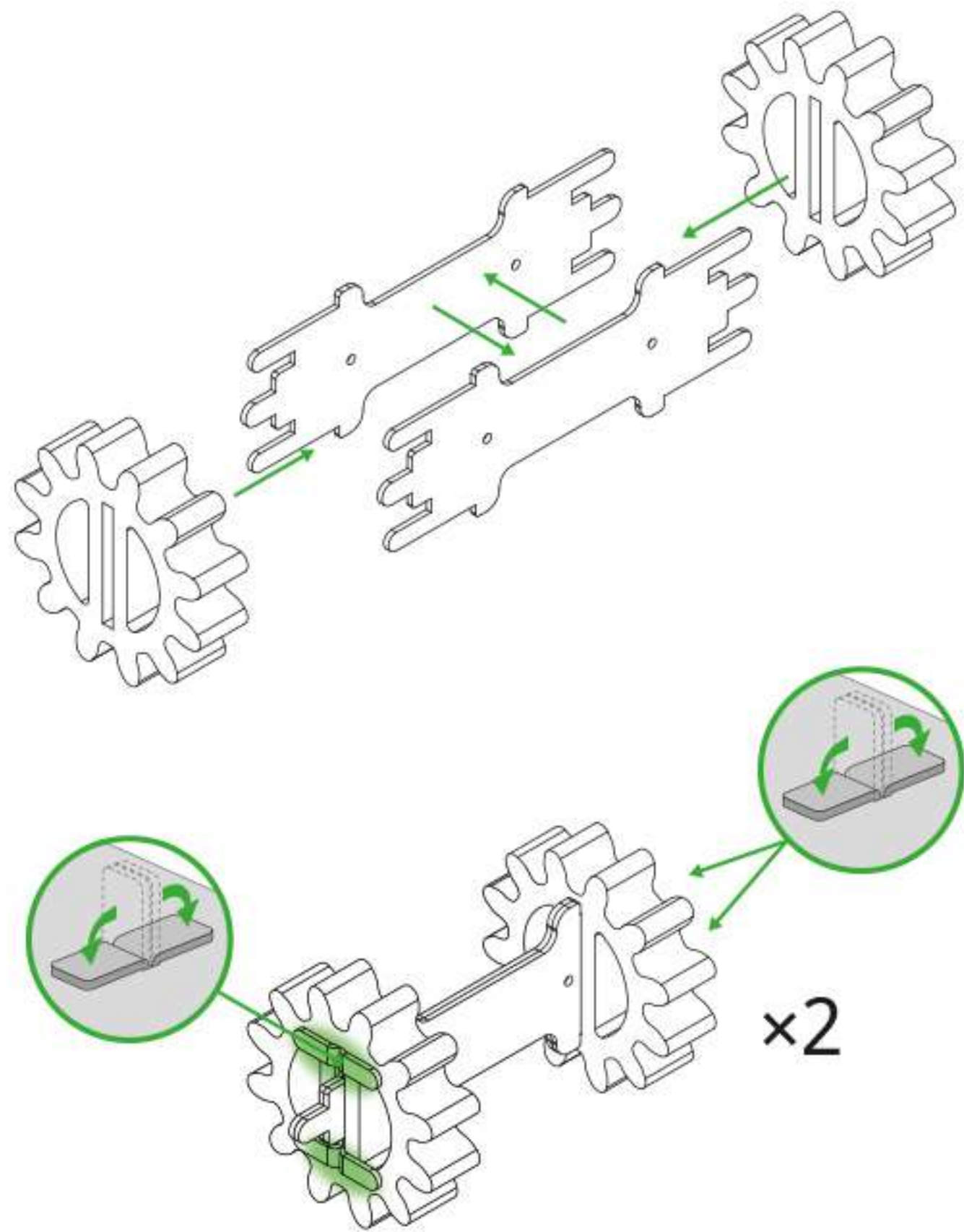

x2

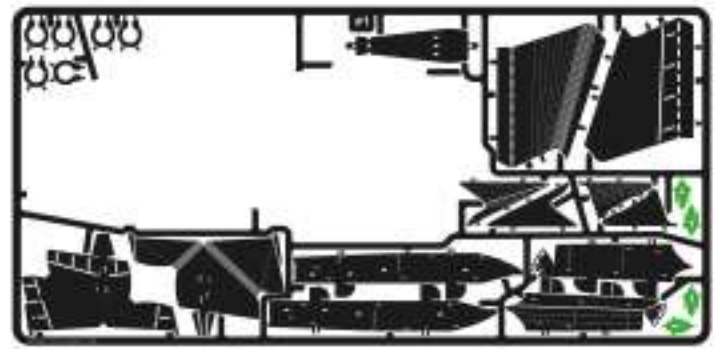

#1

 x2
G8

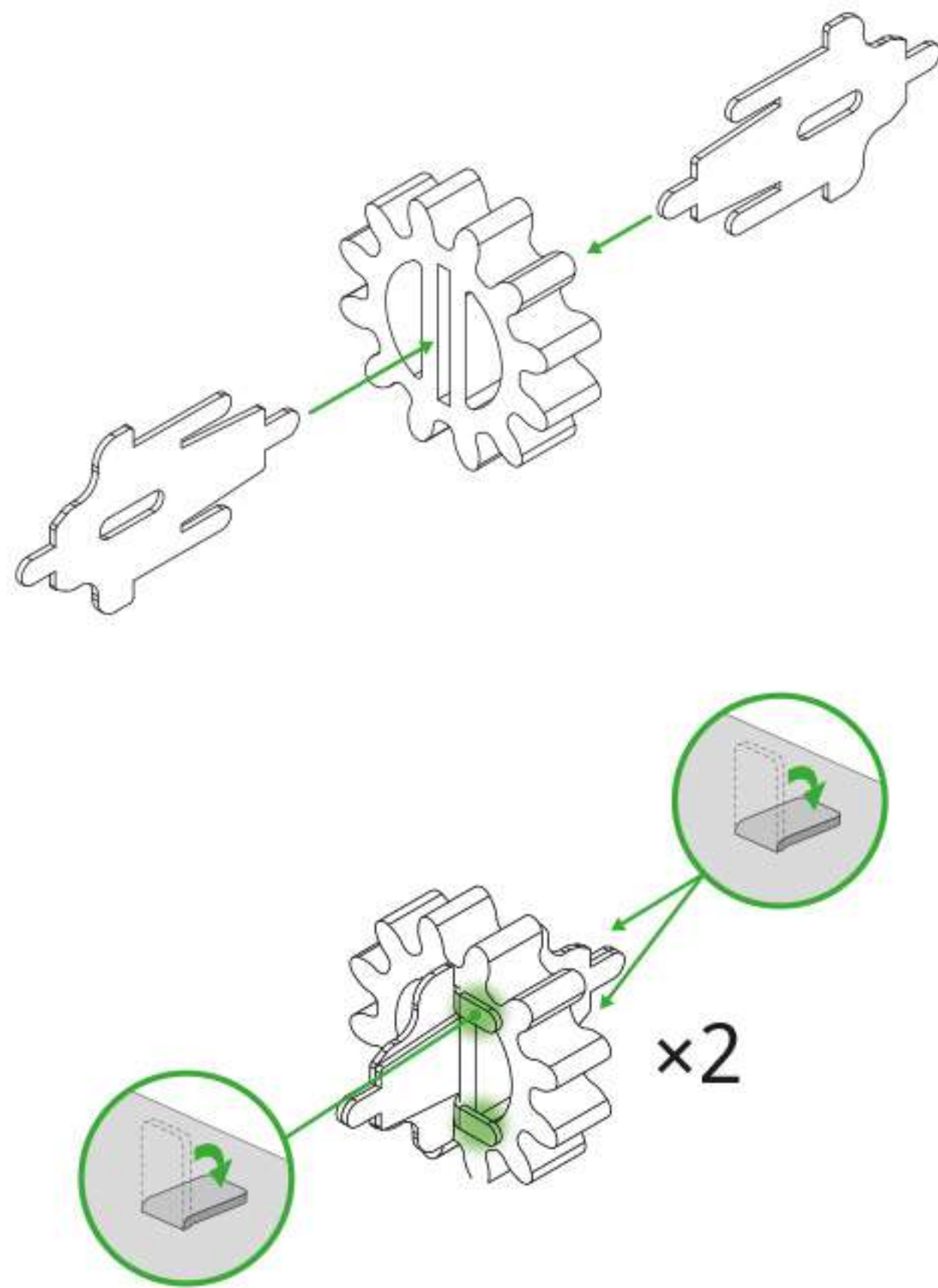

x2

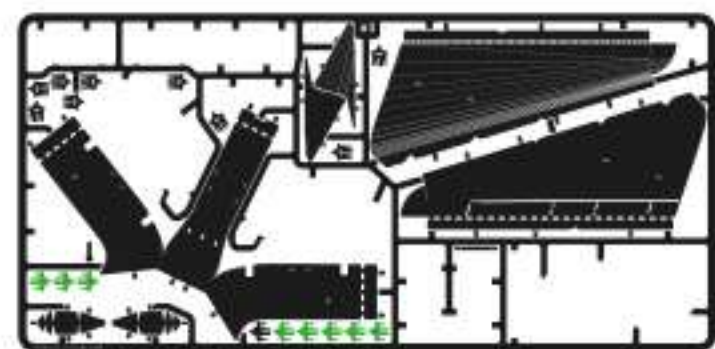

#3

 x2
G4

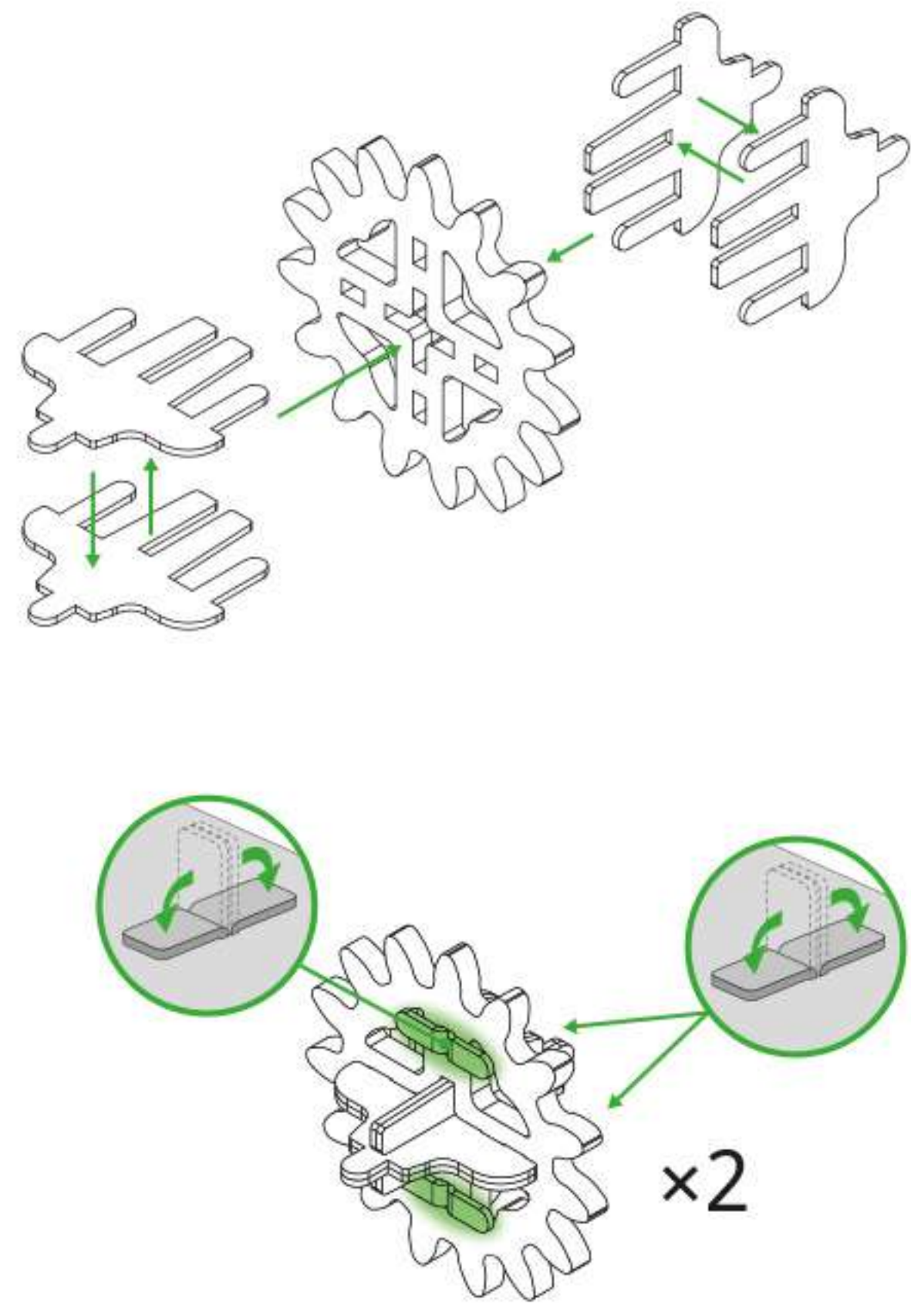

x2

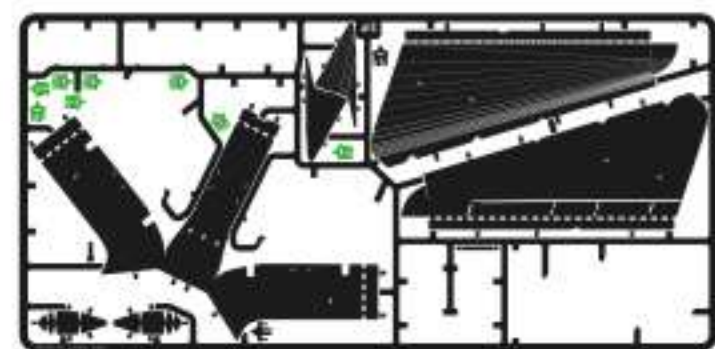

#3

 x2
G6

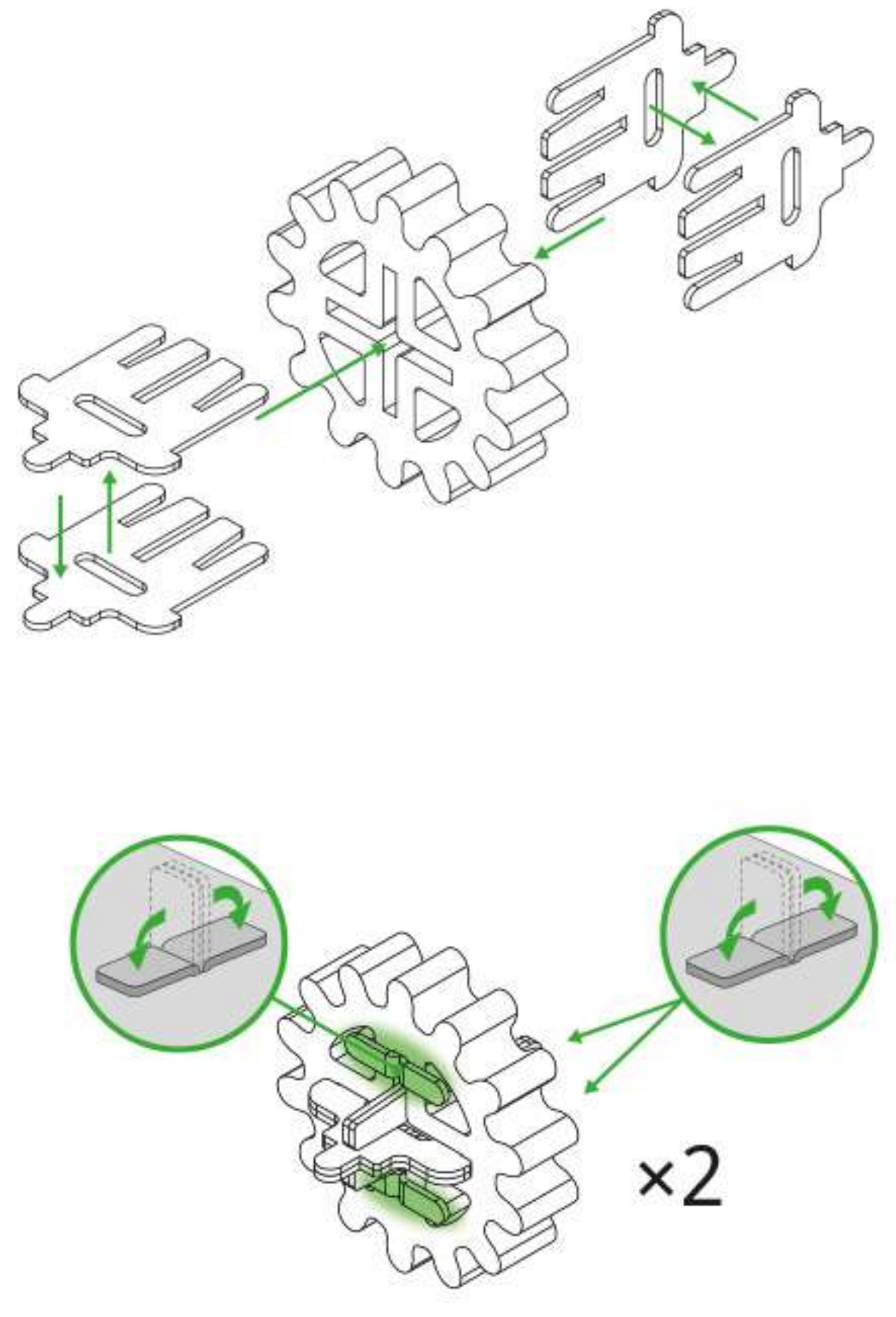

x2

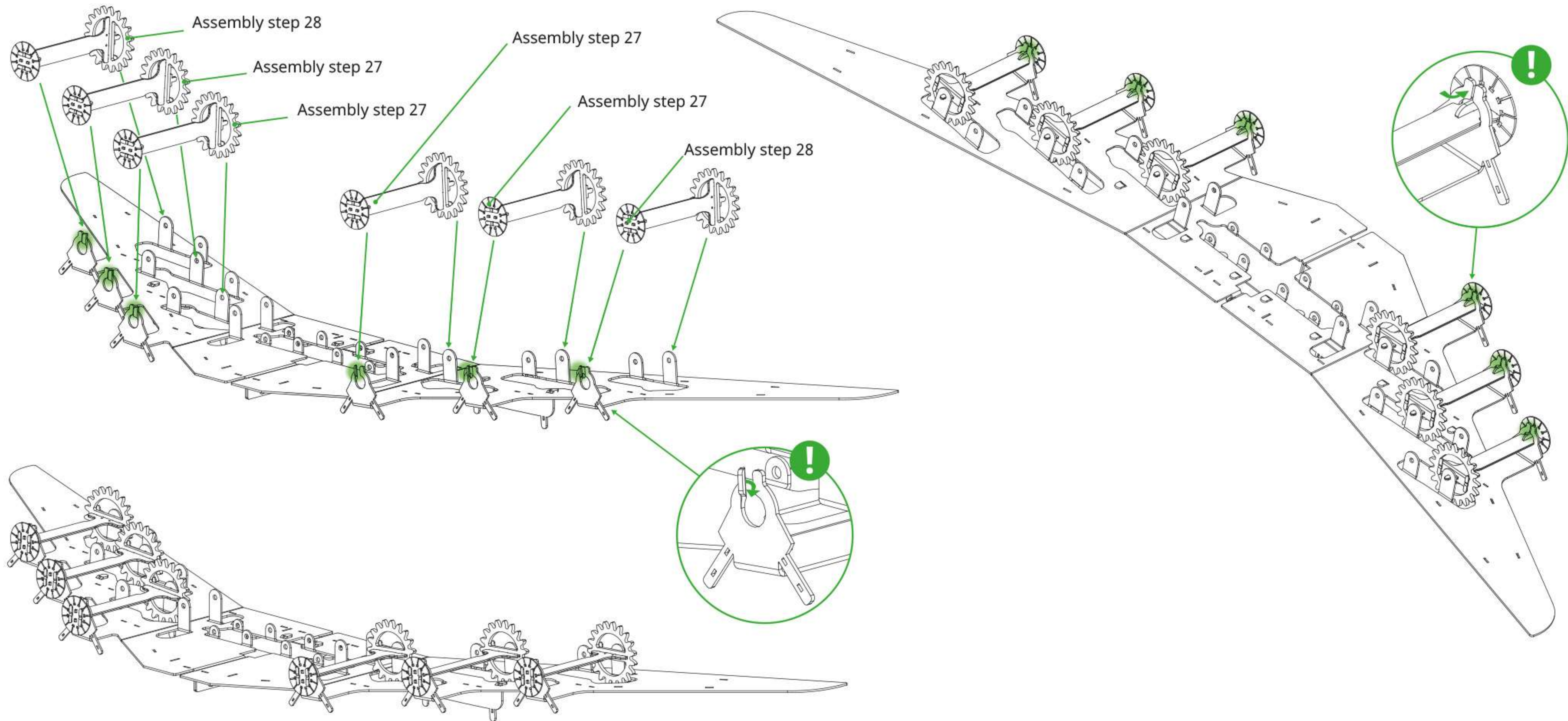

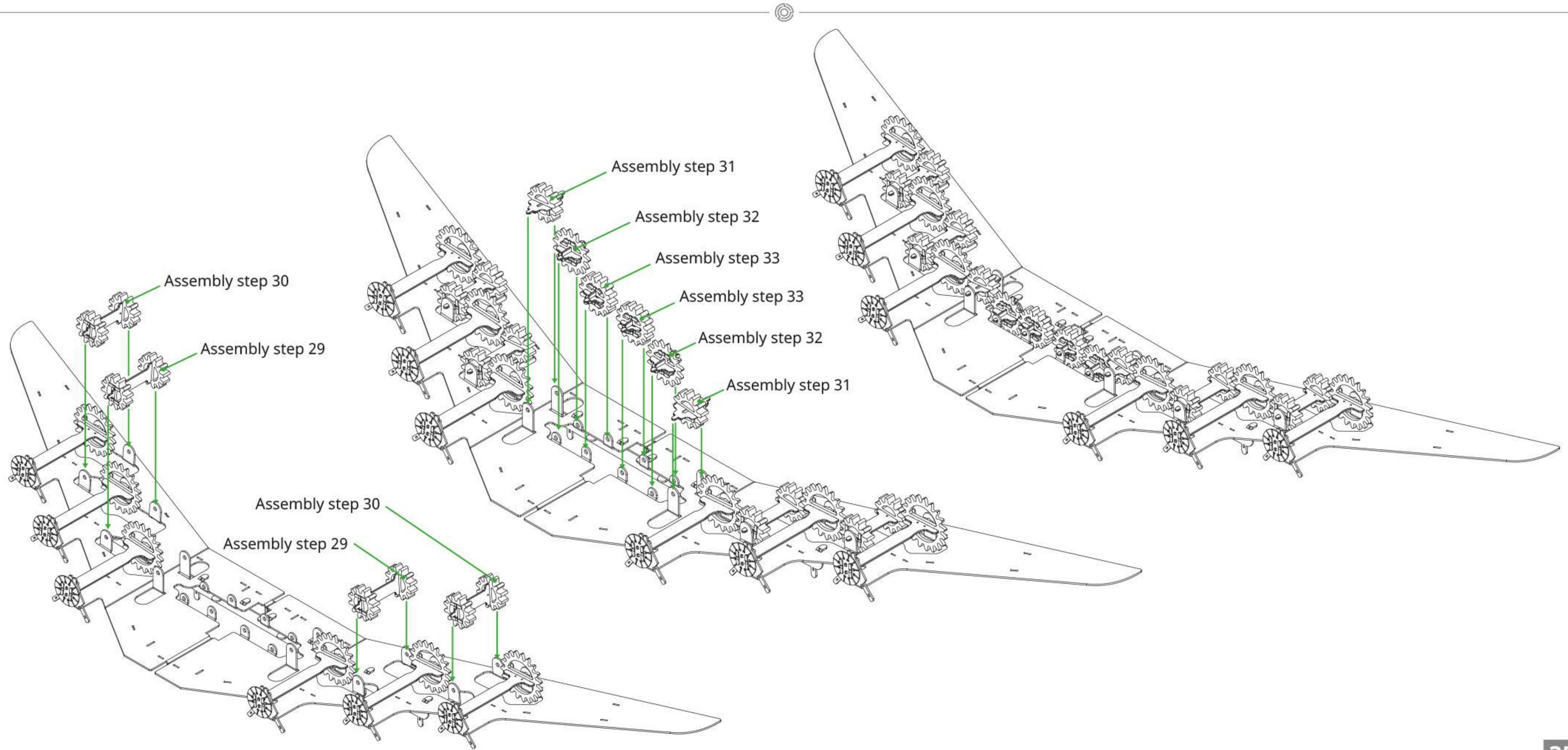

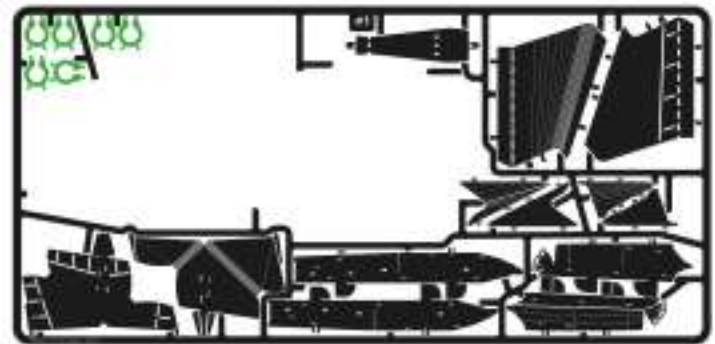

#1

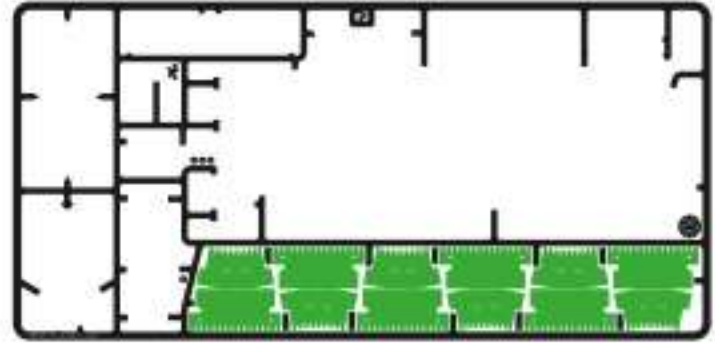

#2

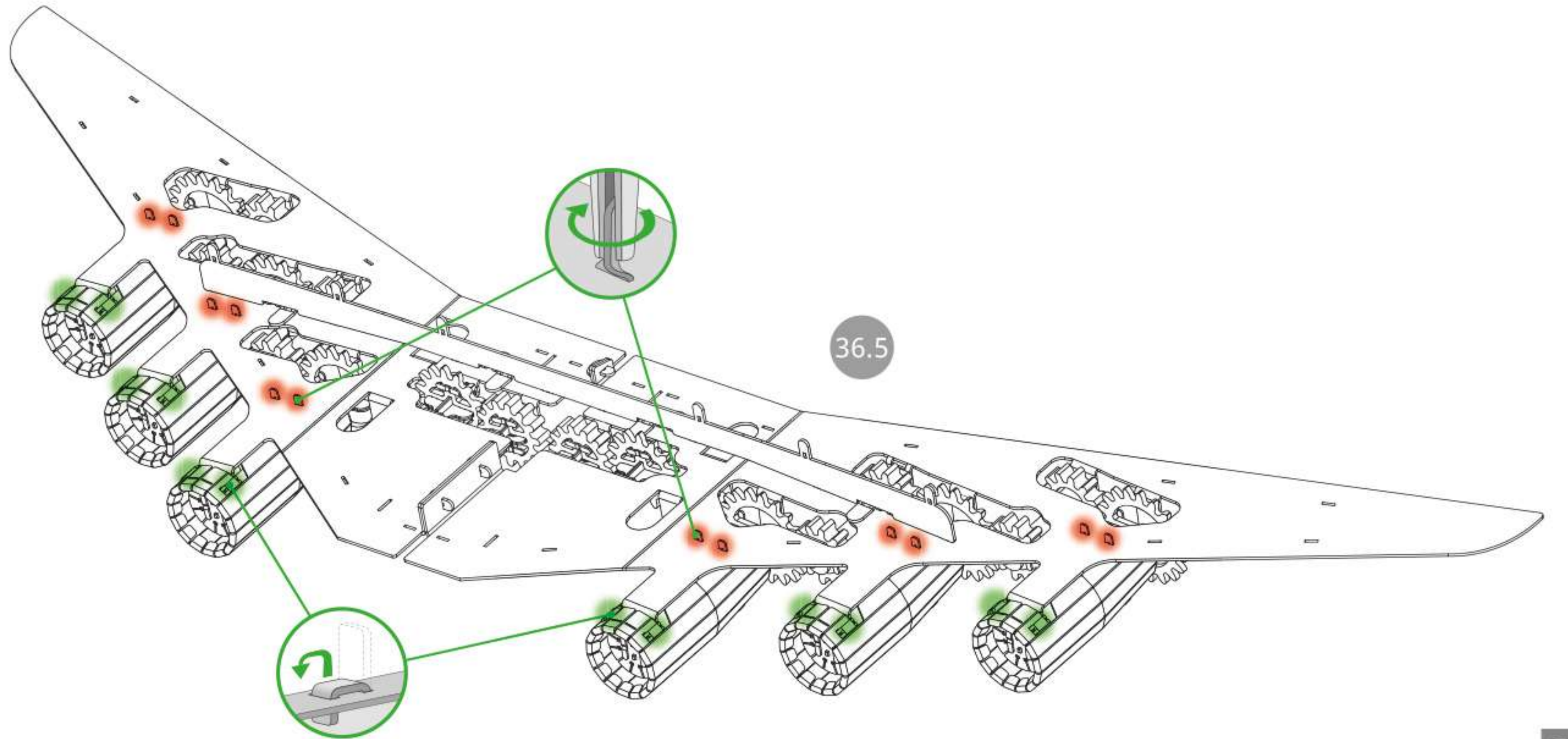
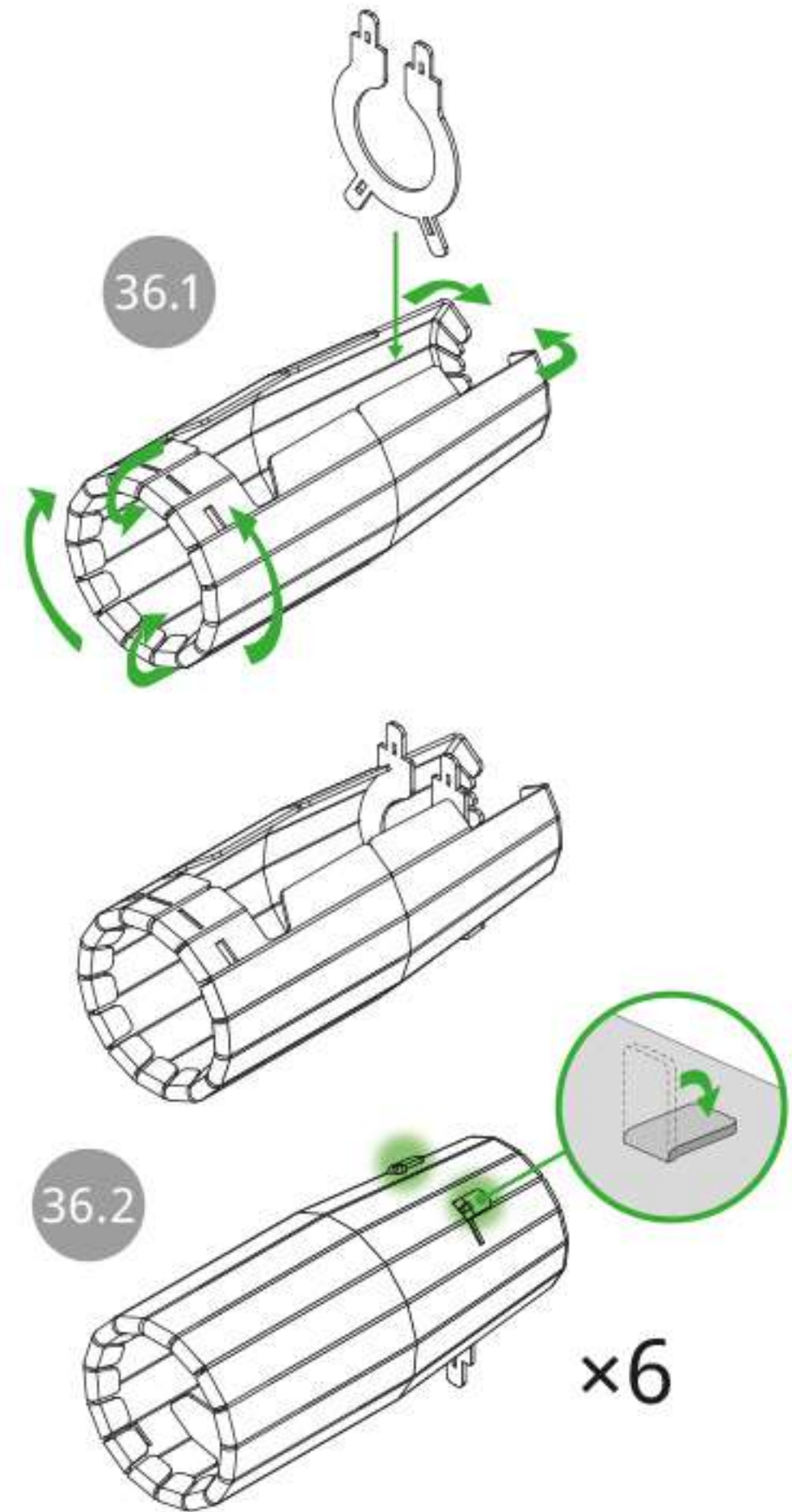
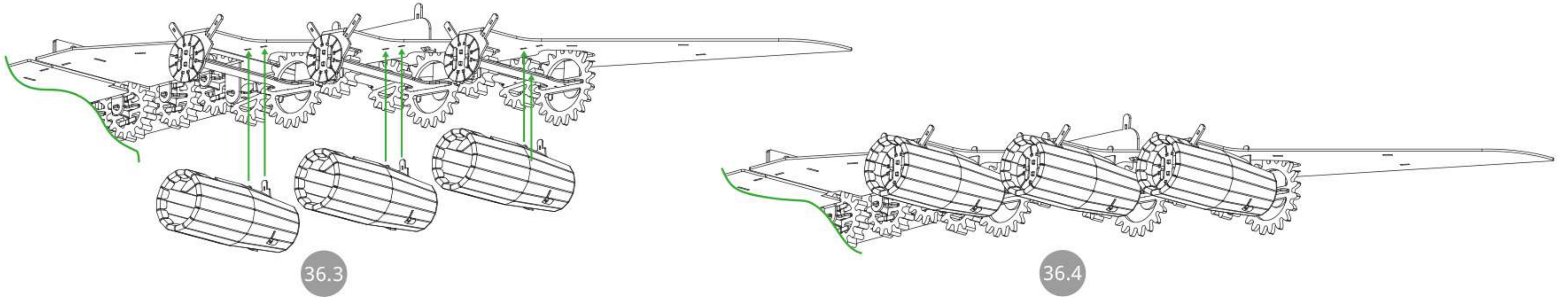

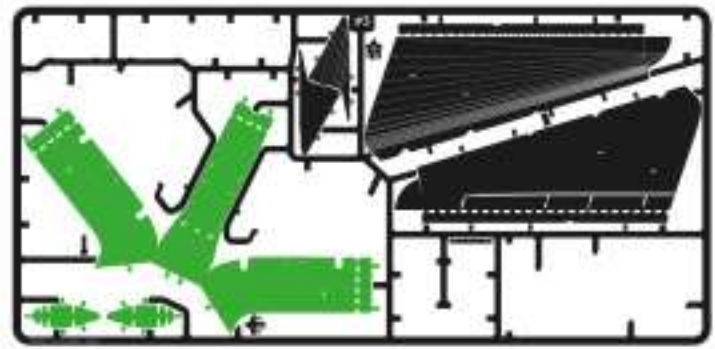

#3

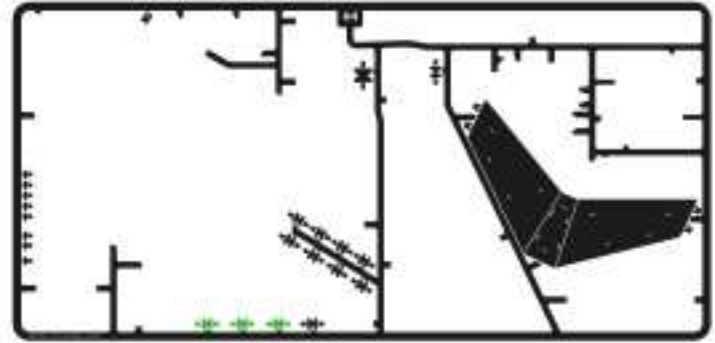

#4

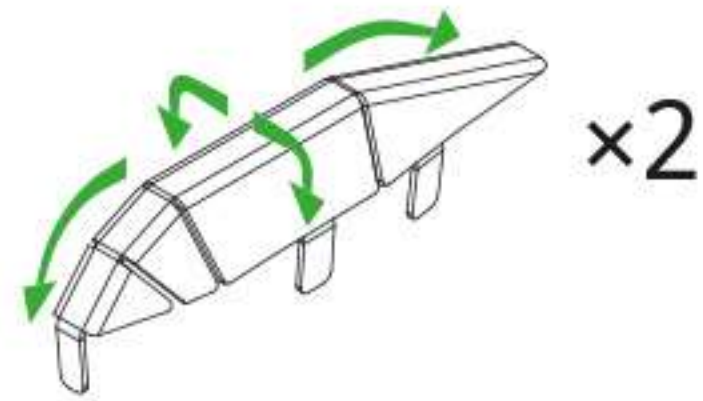

x2

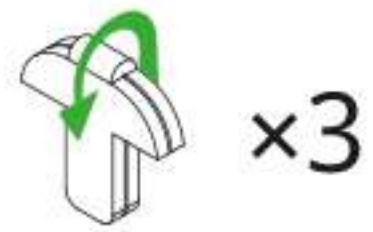

x3

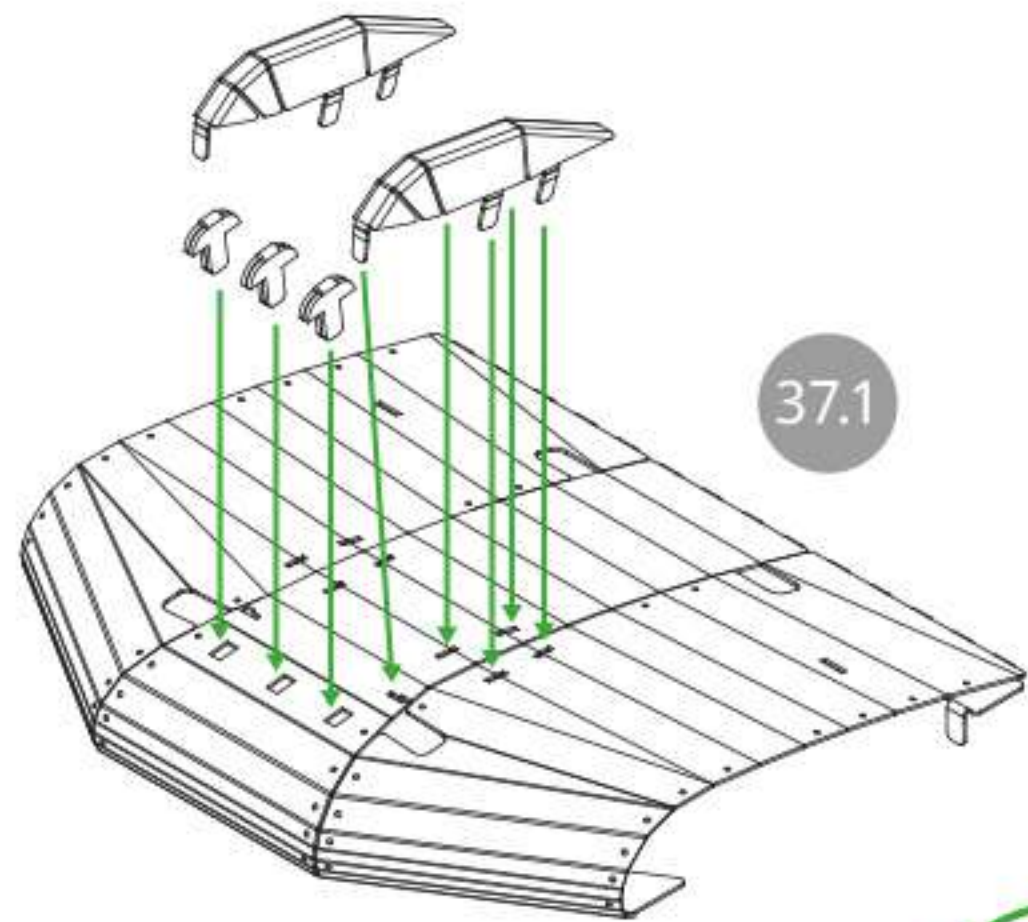
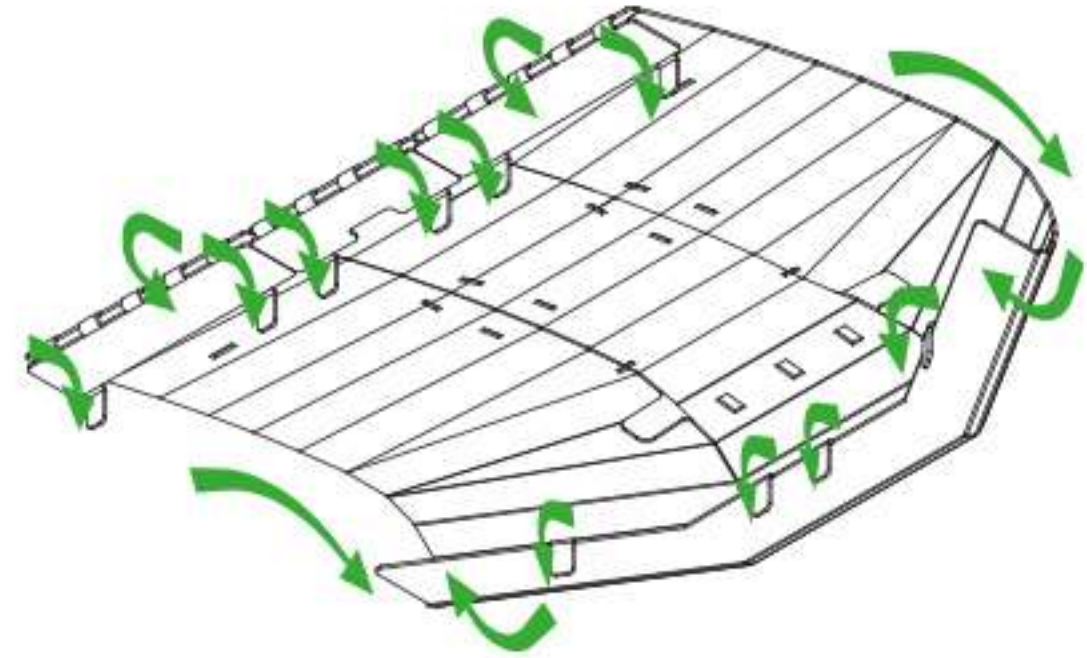

37.1

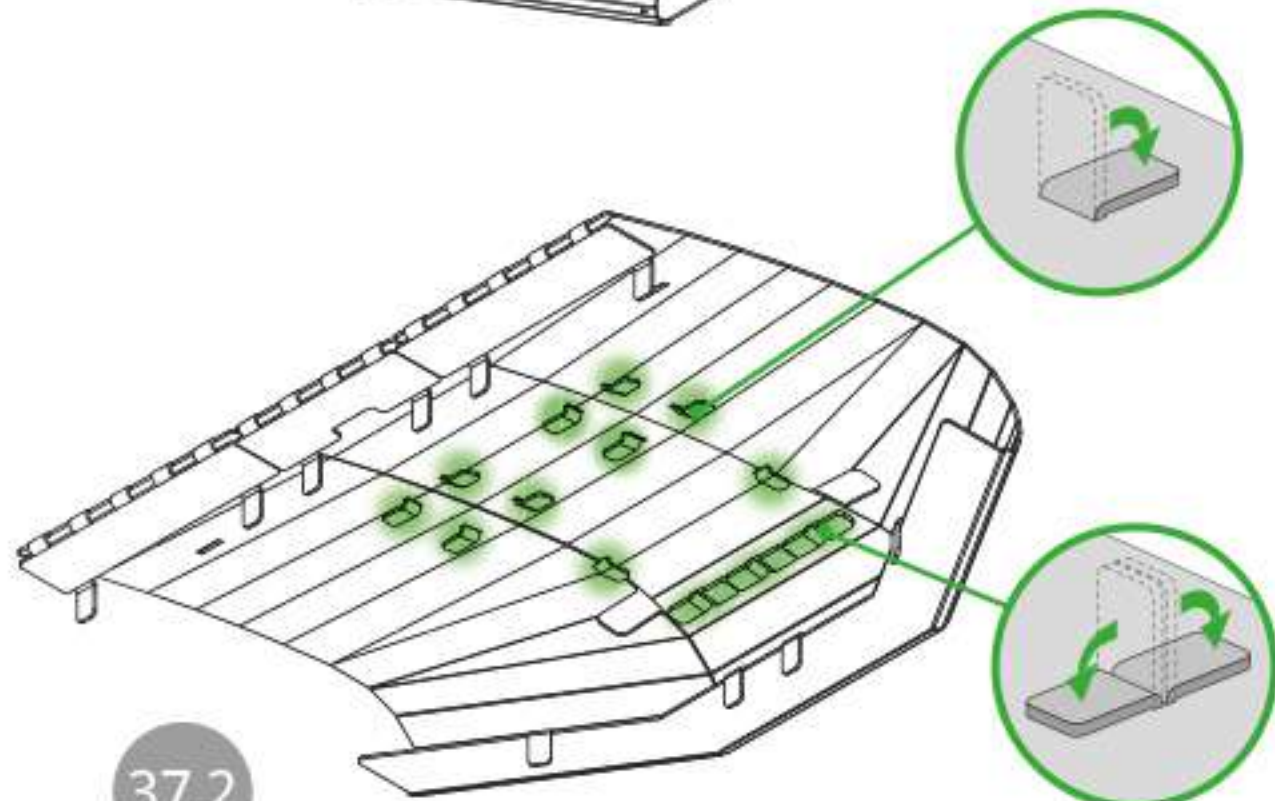

37.2

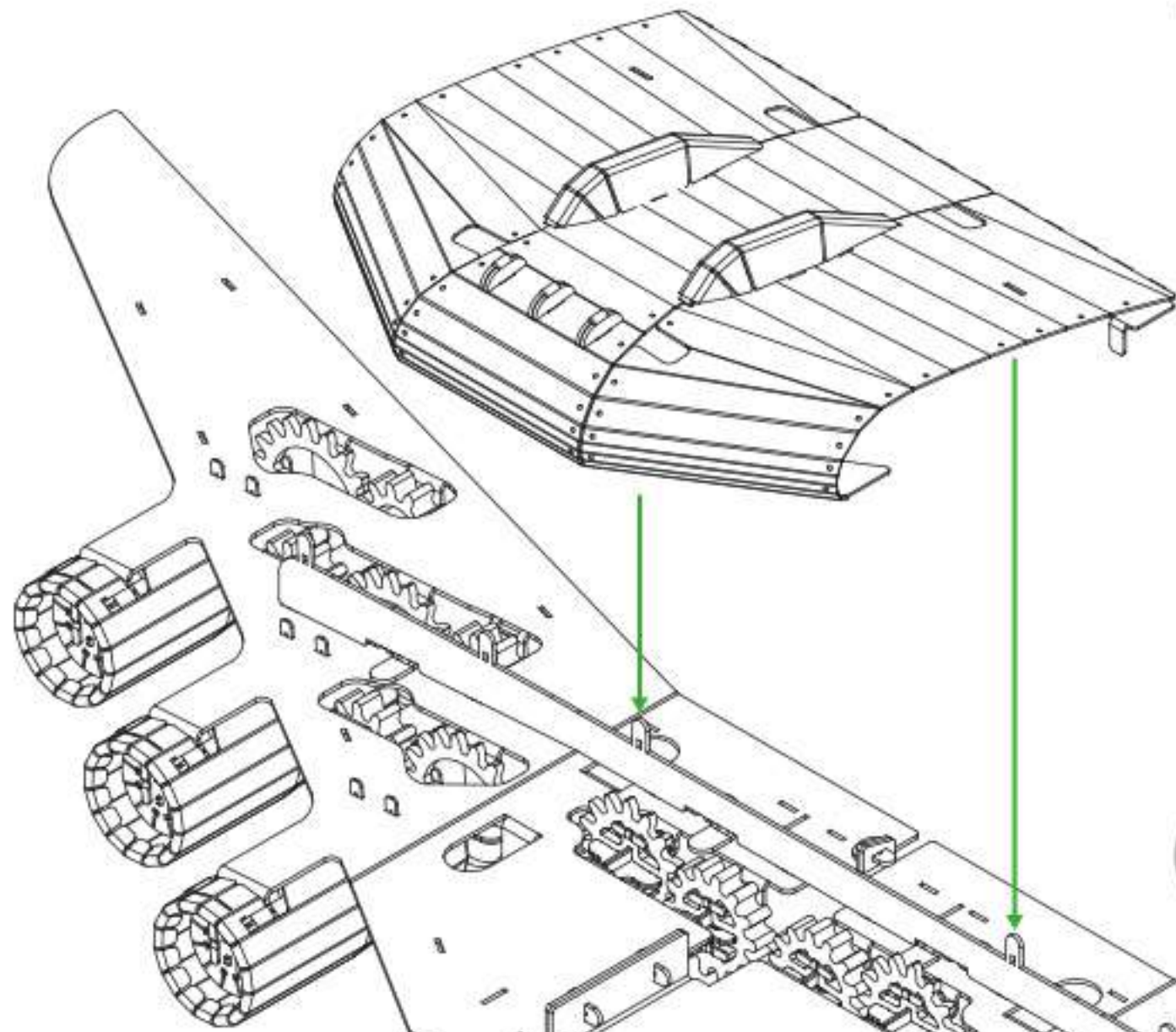

37.3

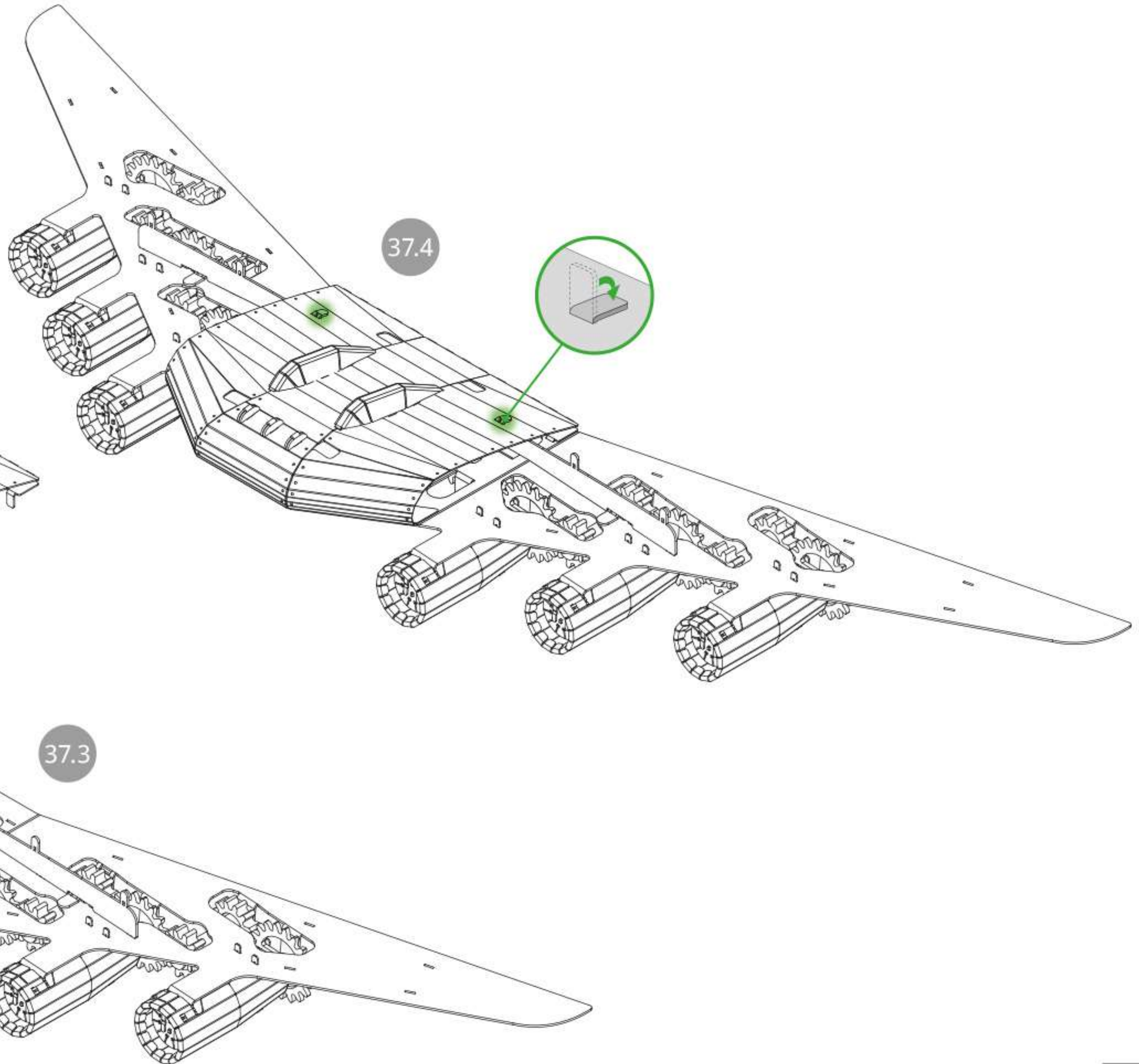

37.4

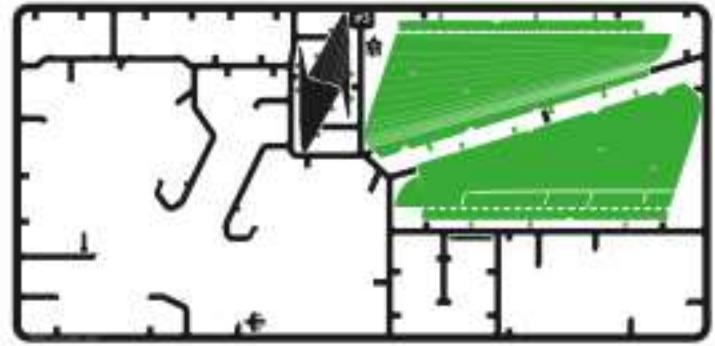

#3

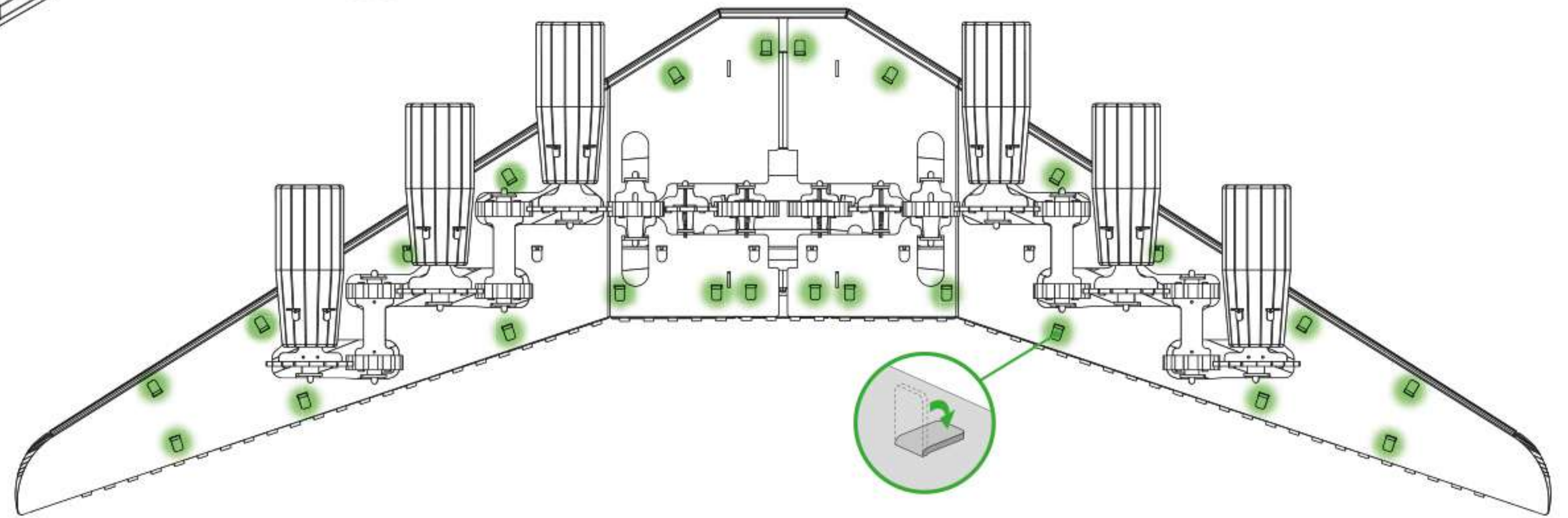
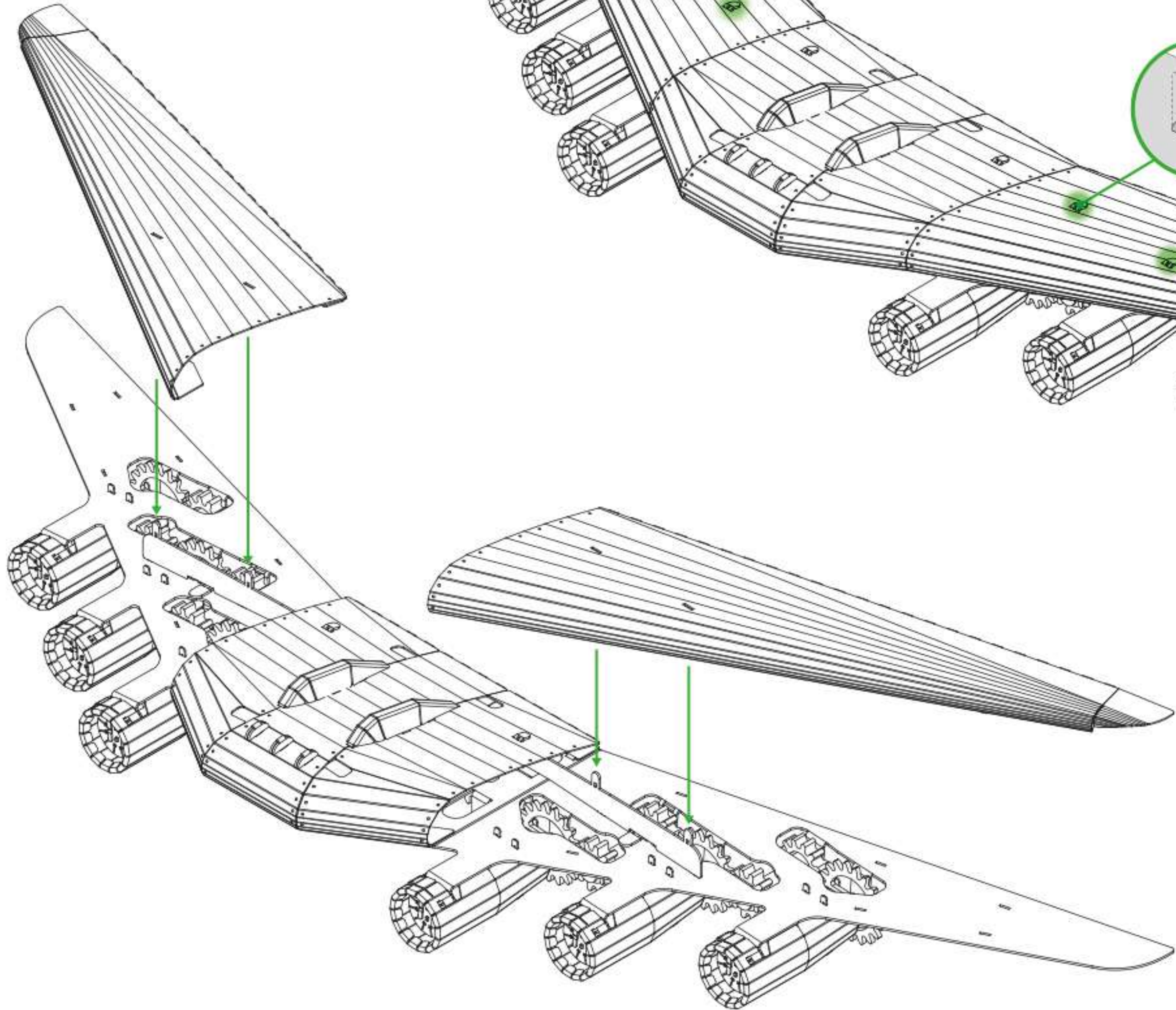
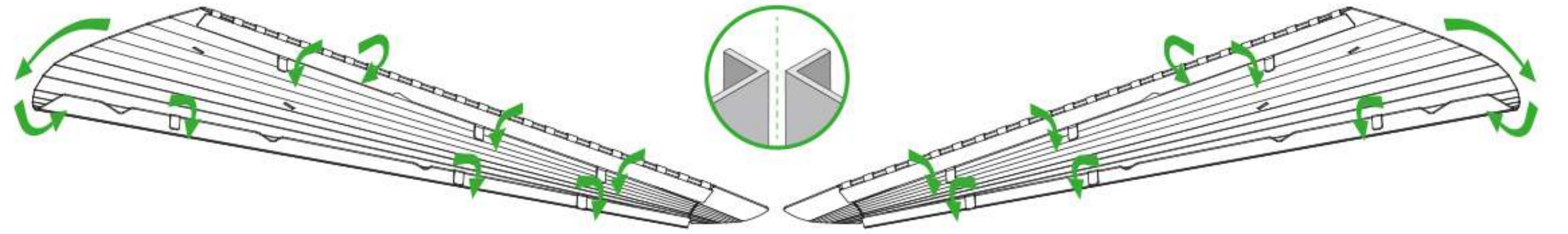
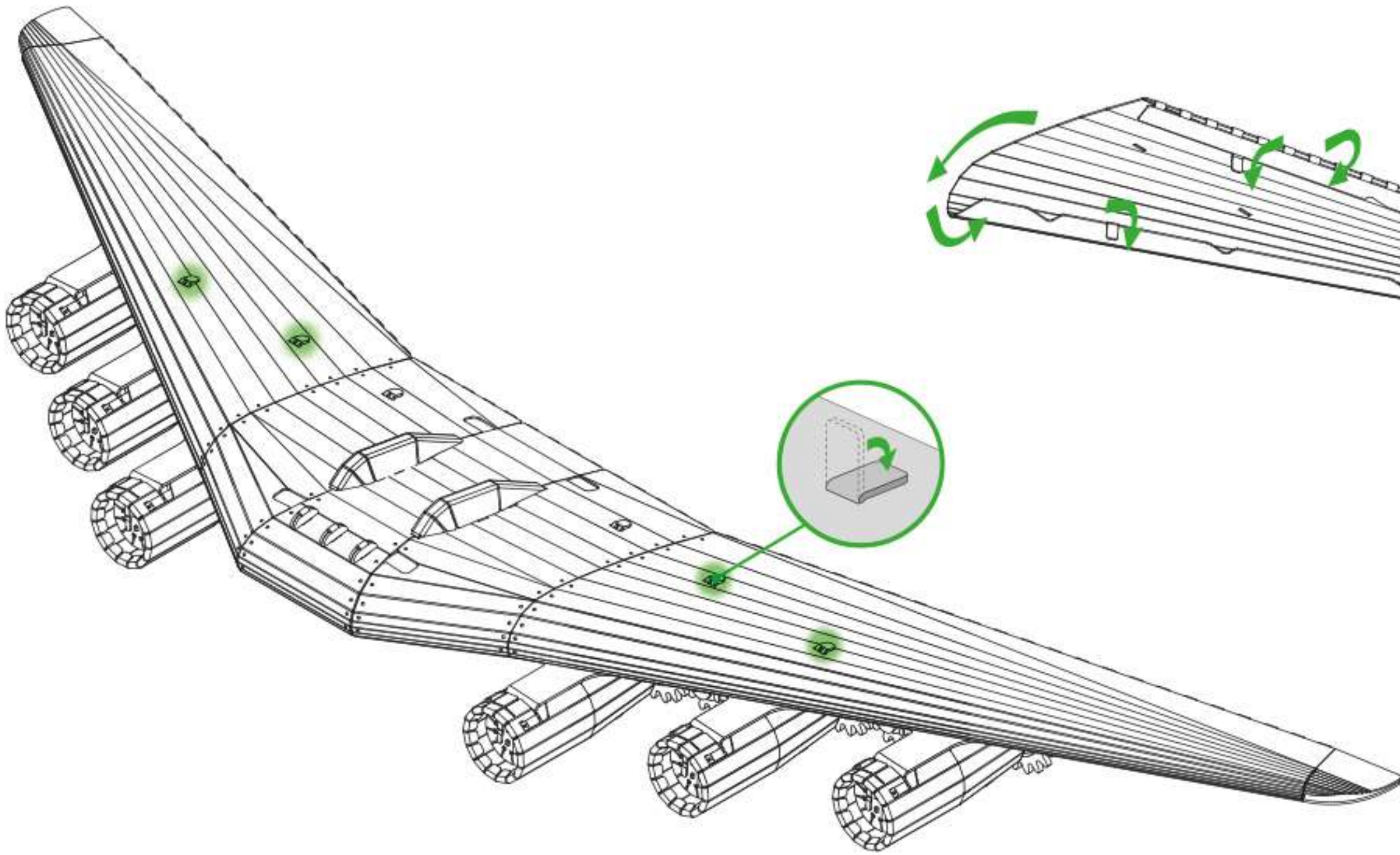

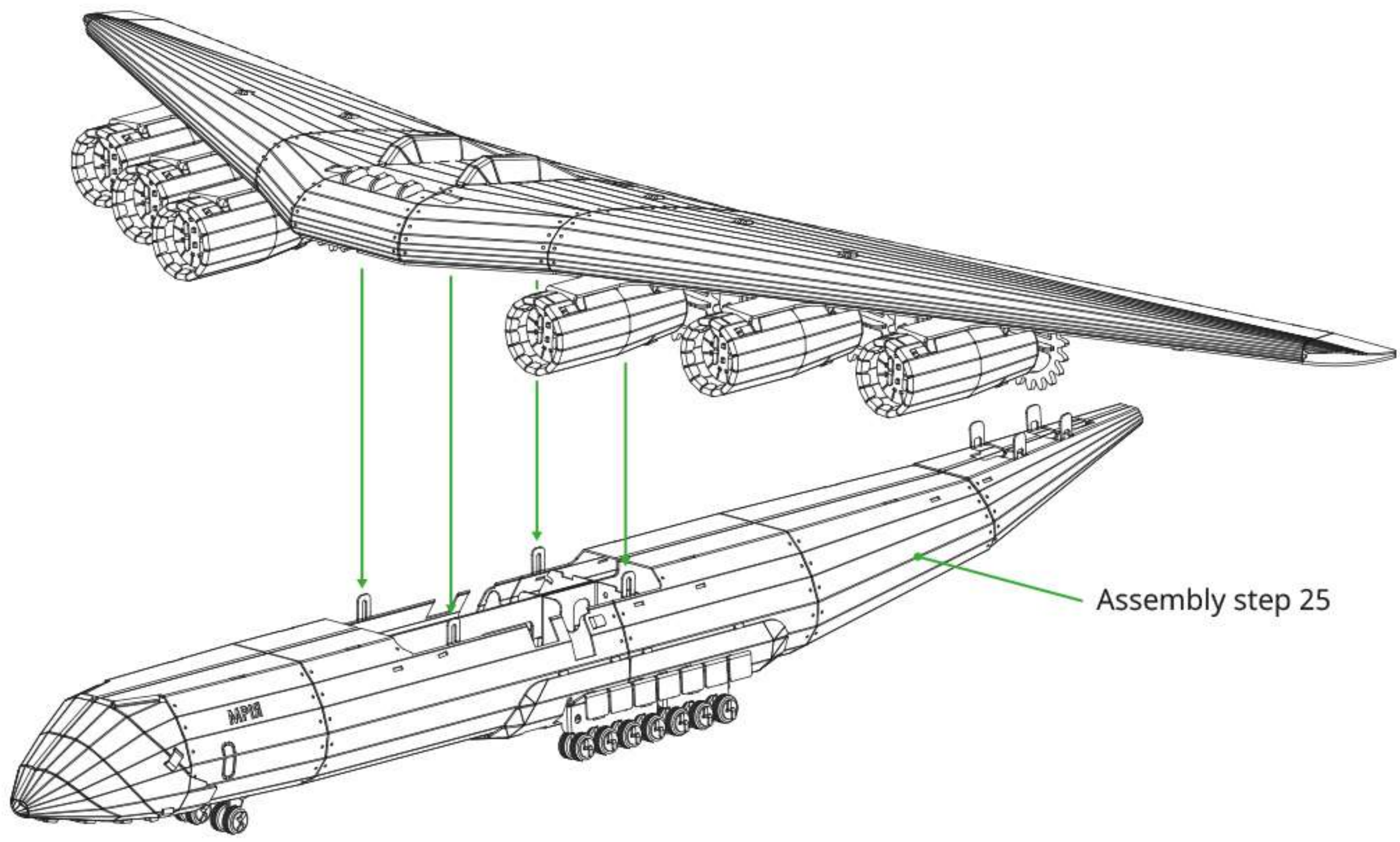

Assembly step 25

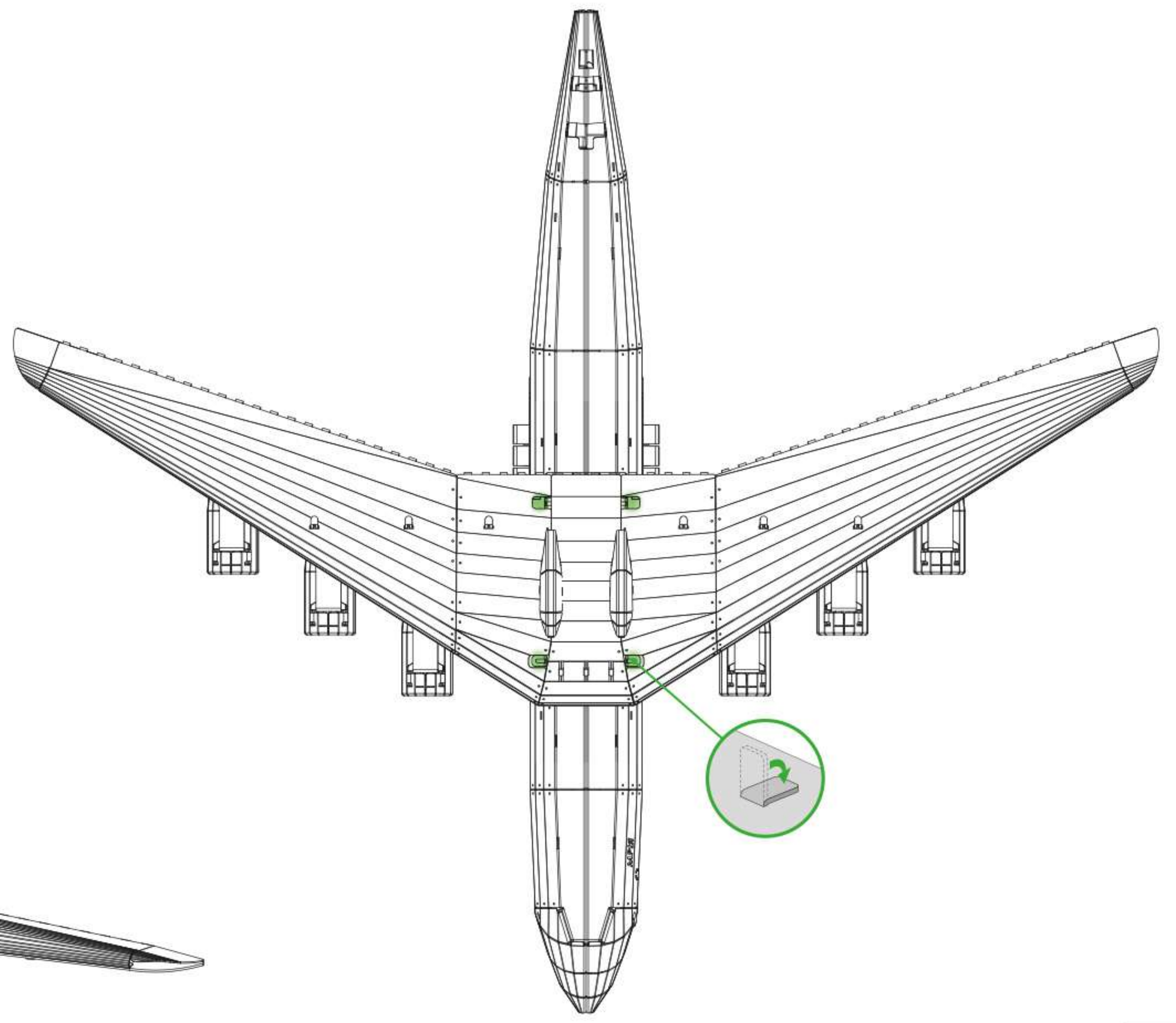
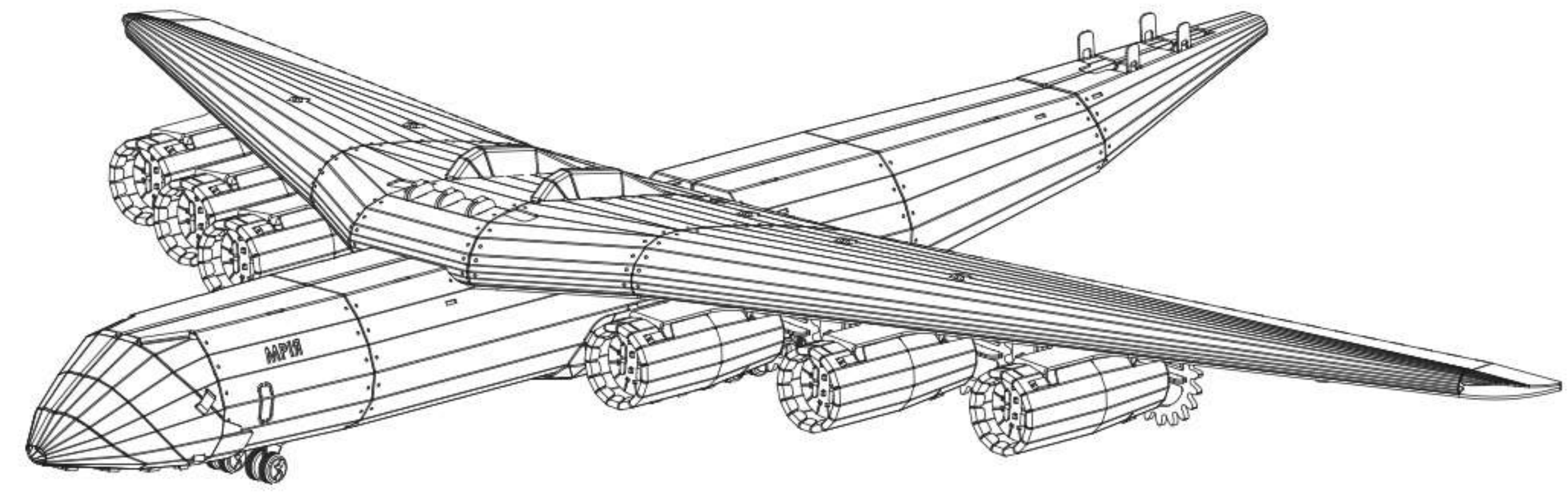

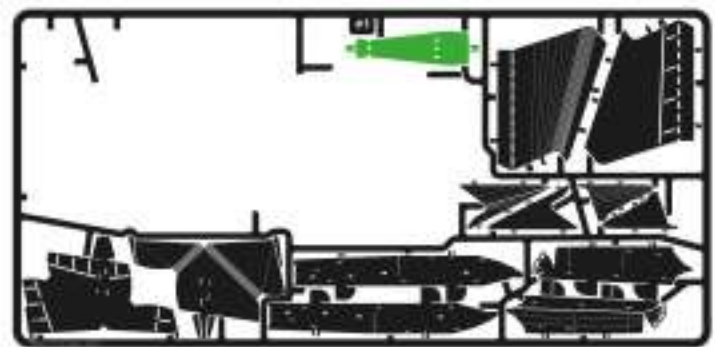

#1

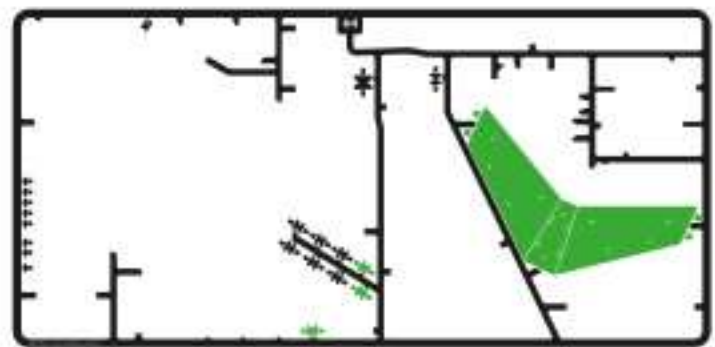

#4

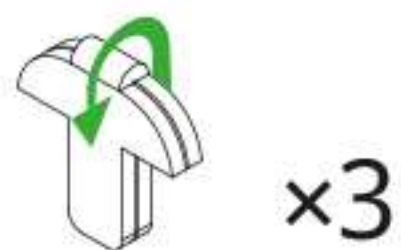
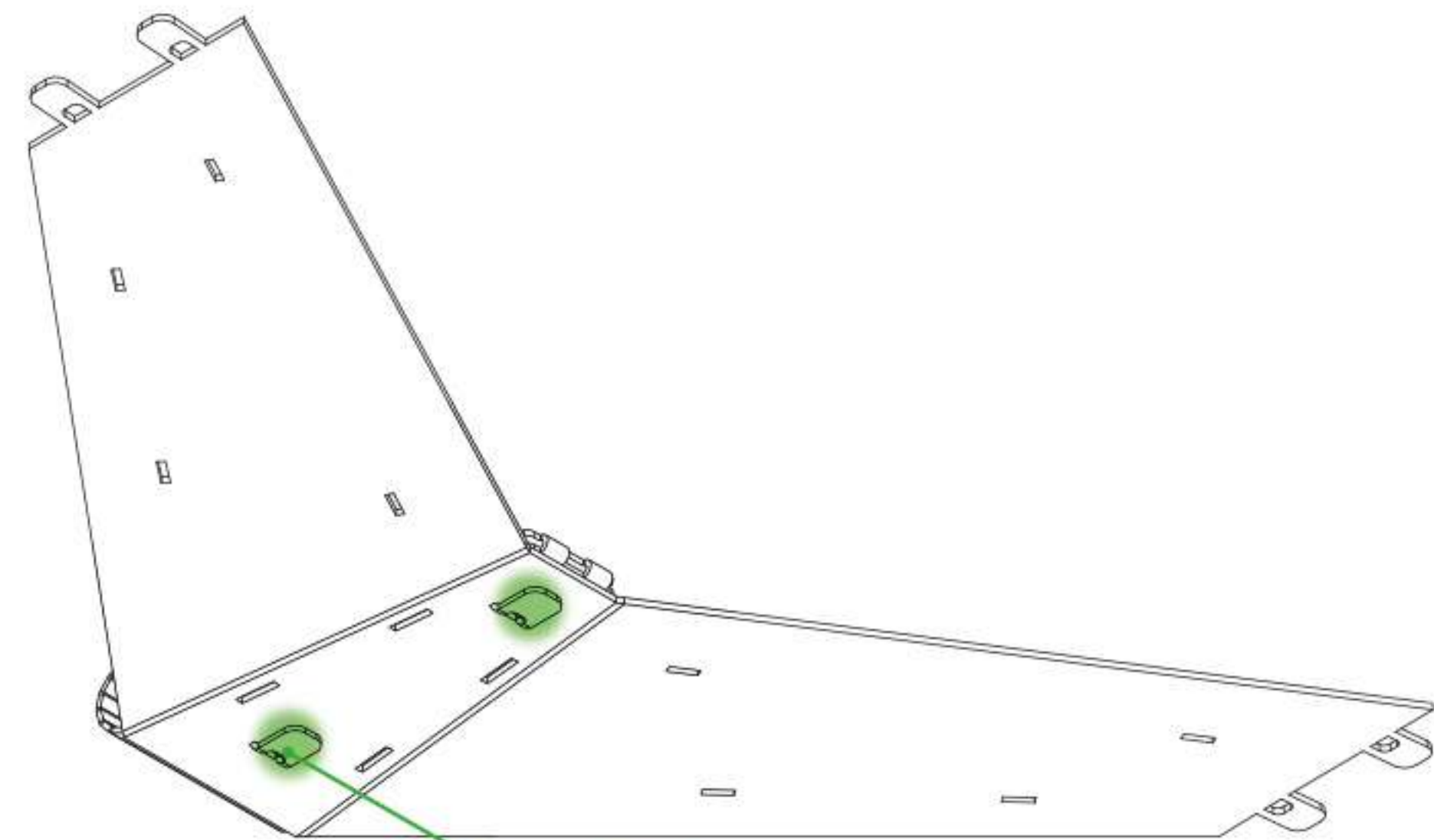
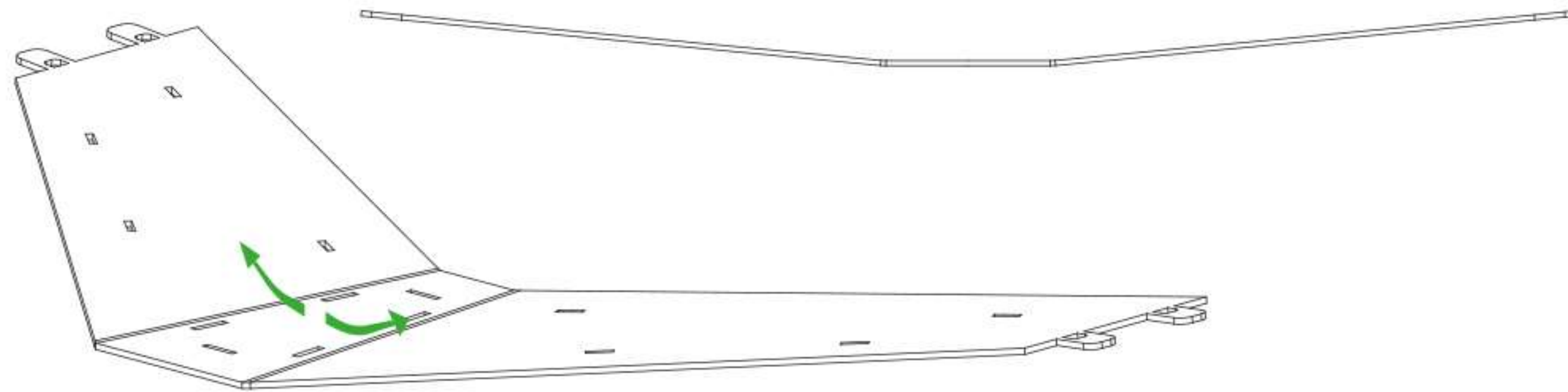

x3

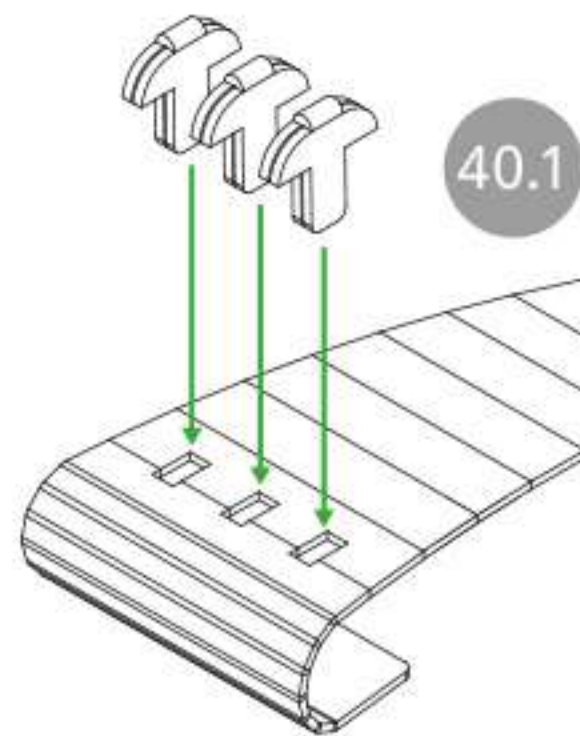
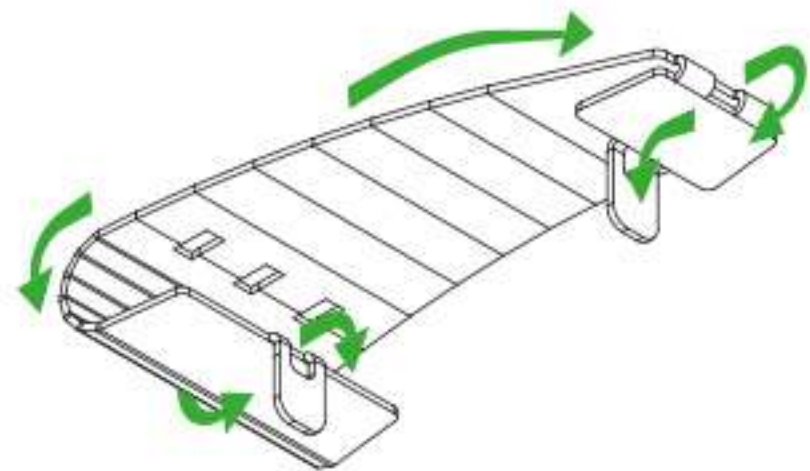

40.1

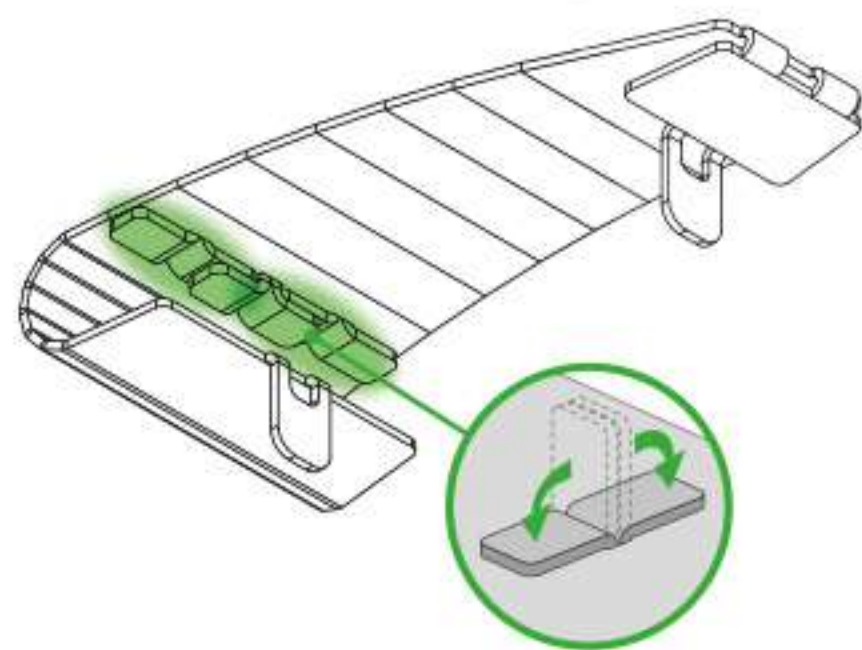

40.2

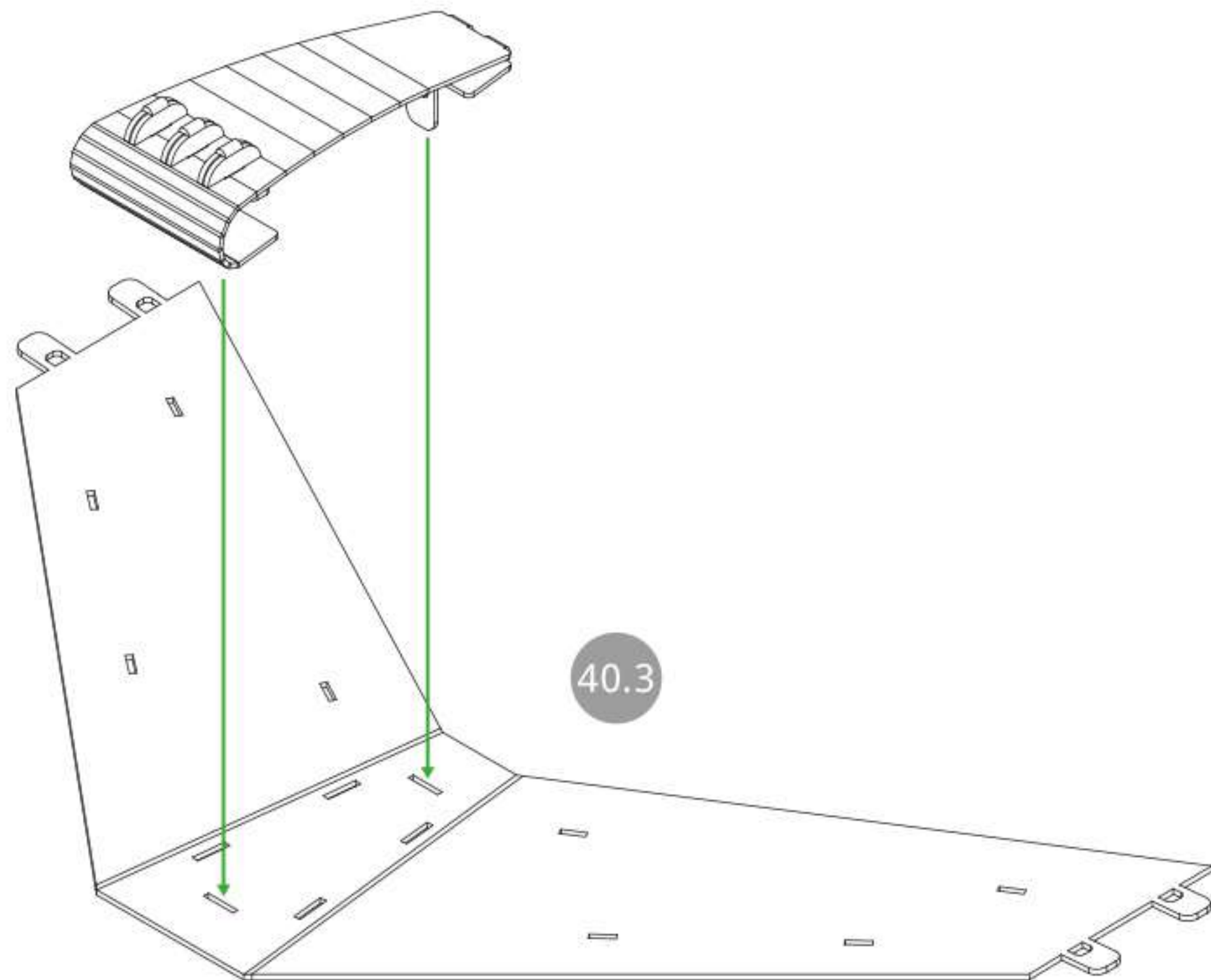

40.3

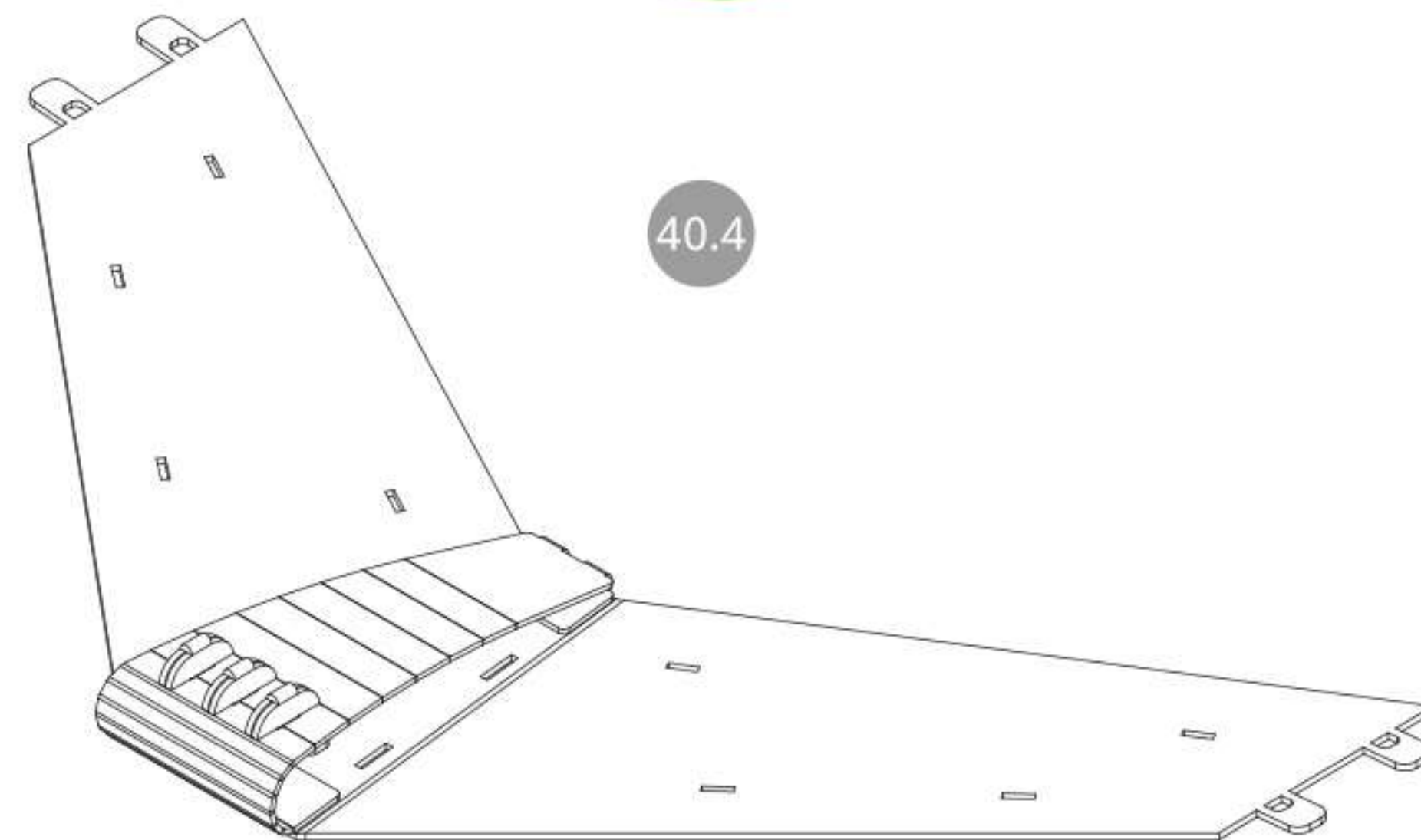

40.4

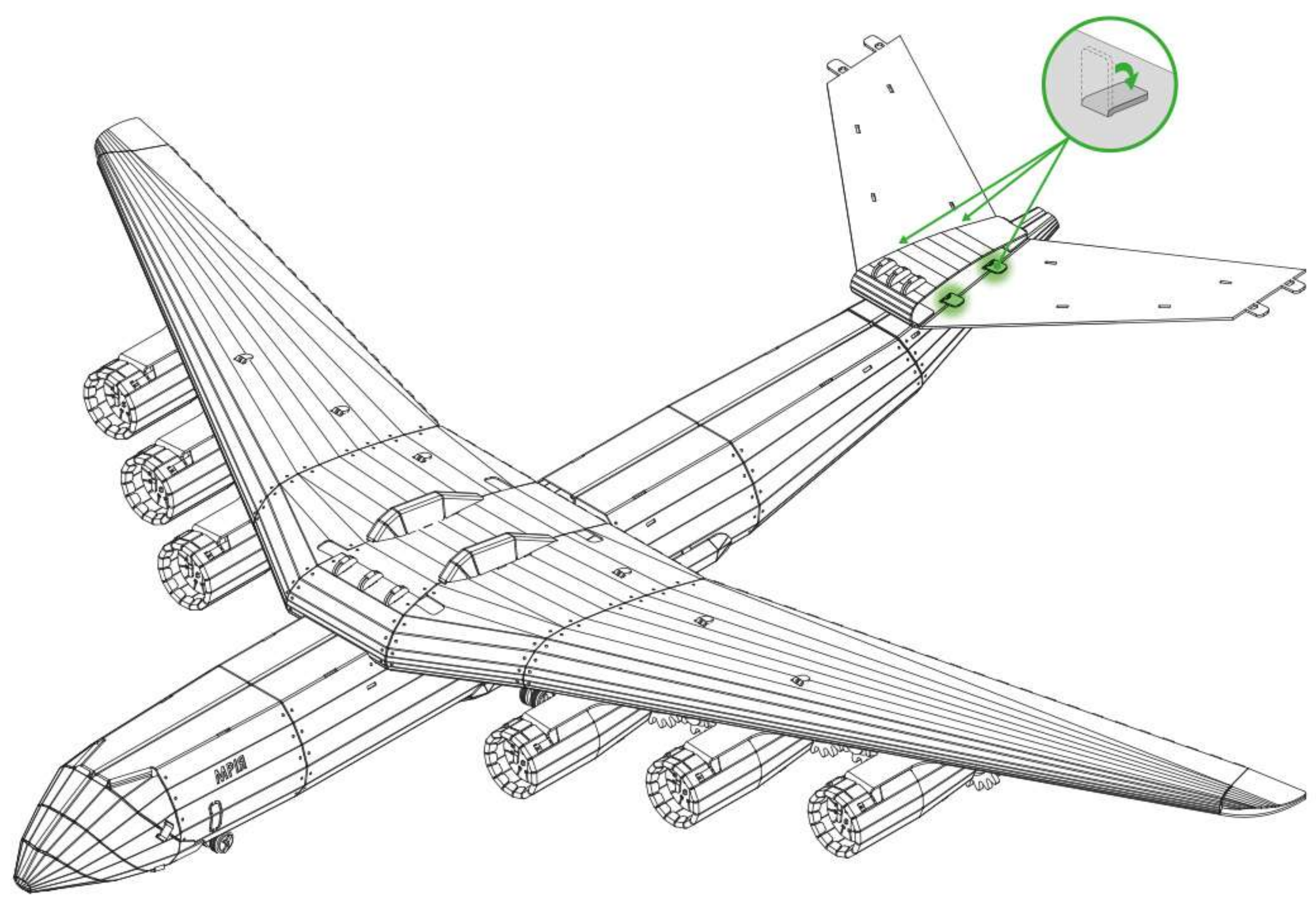
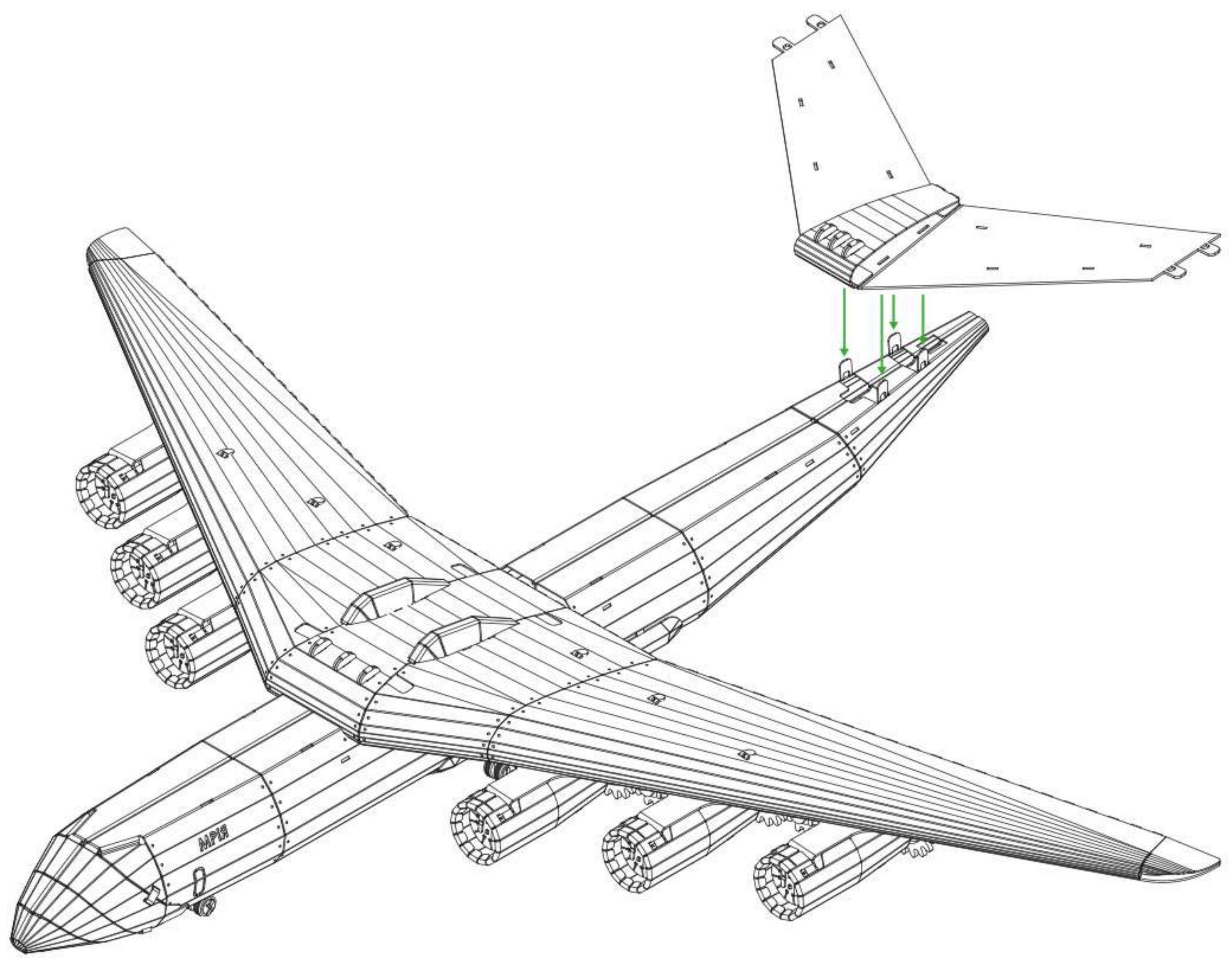

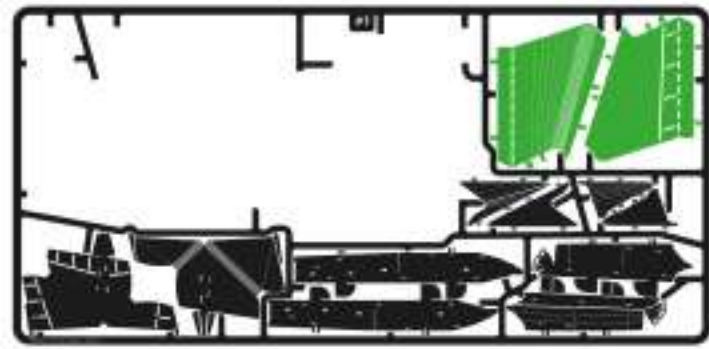

#1

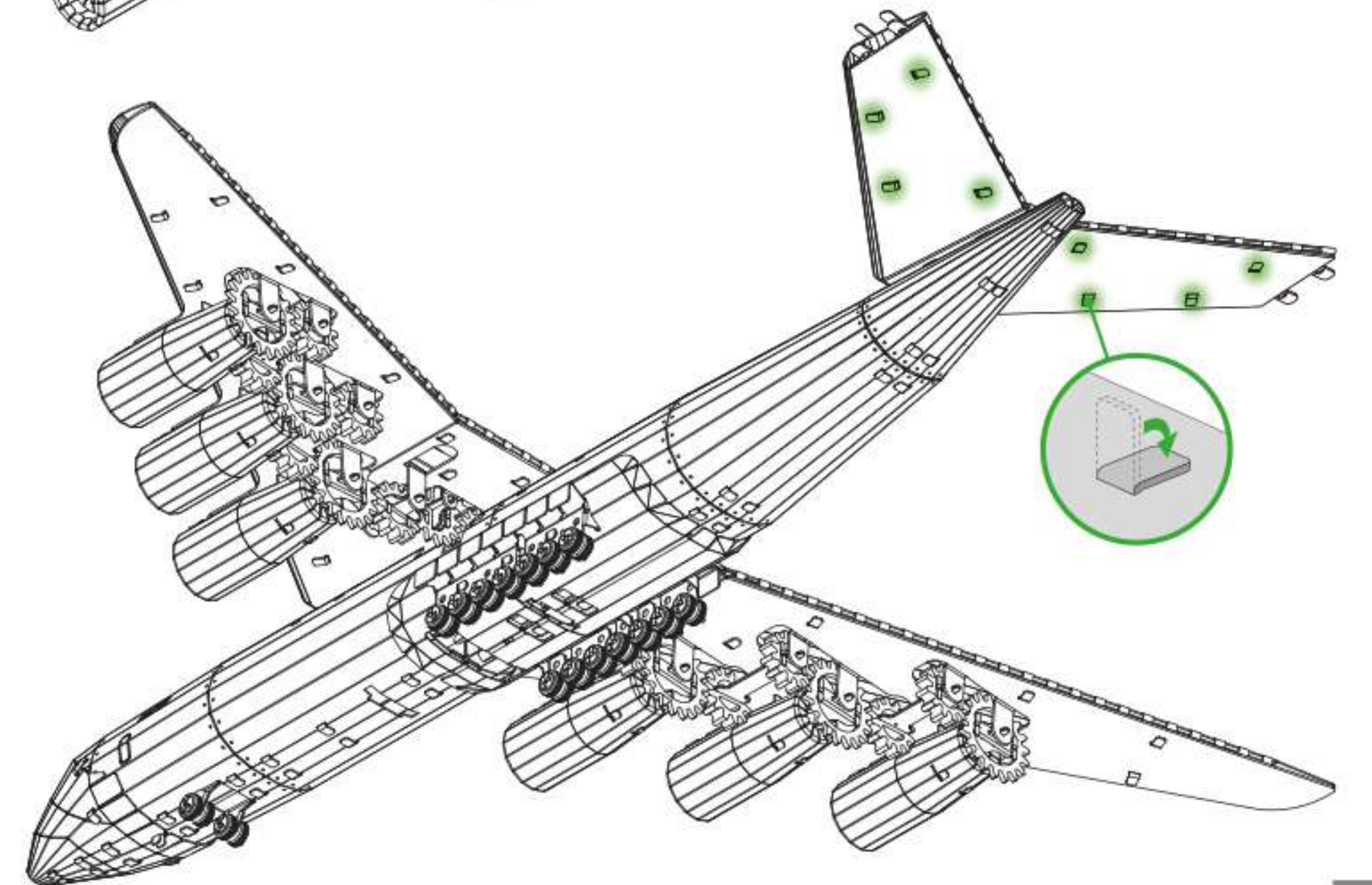
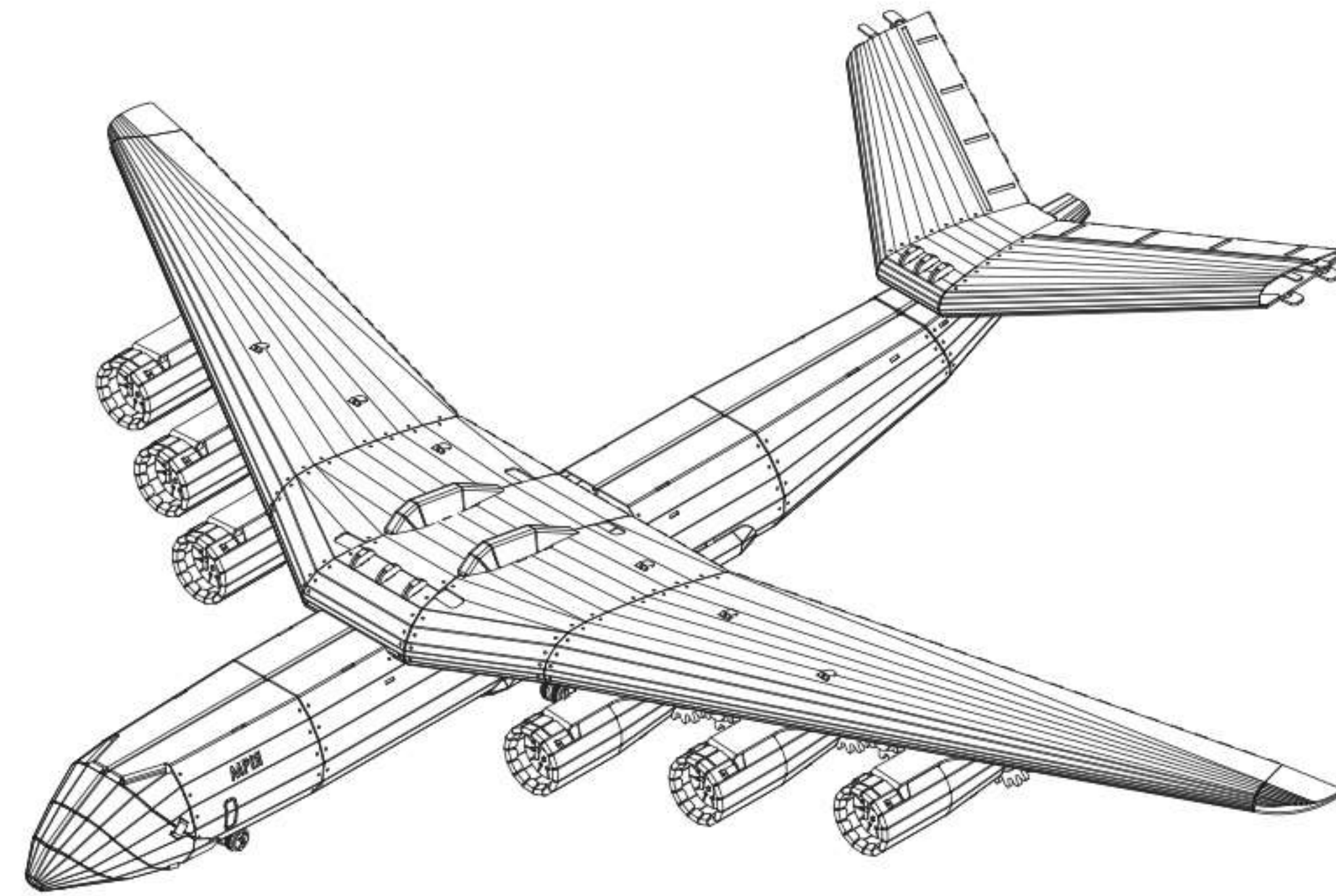
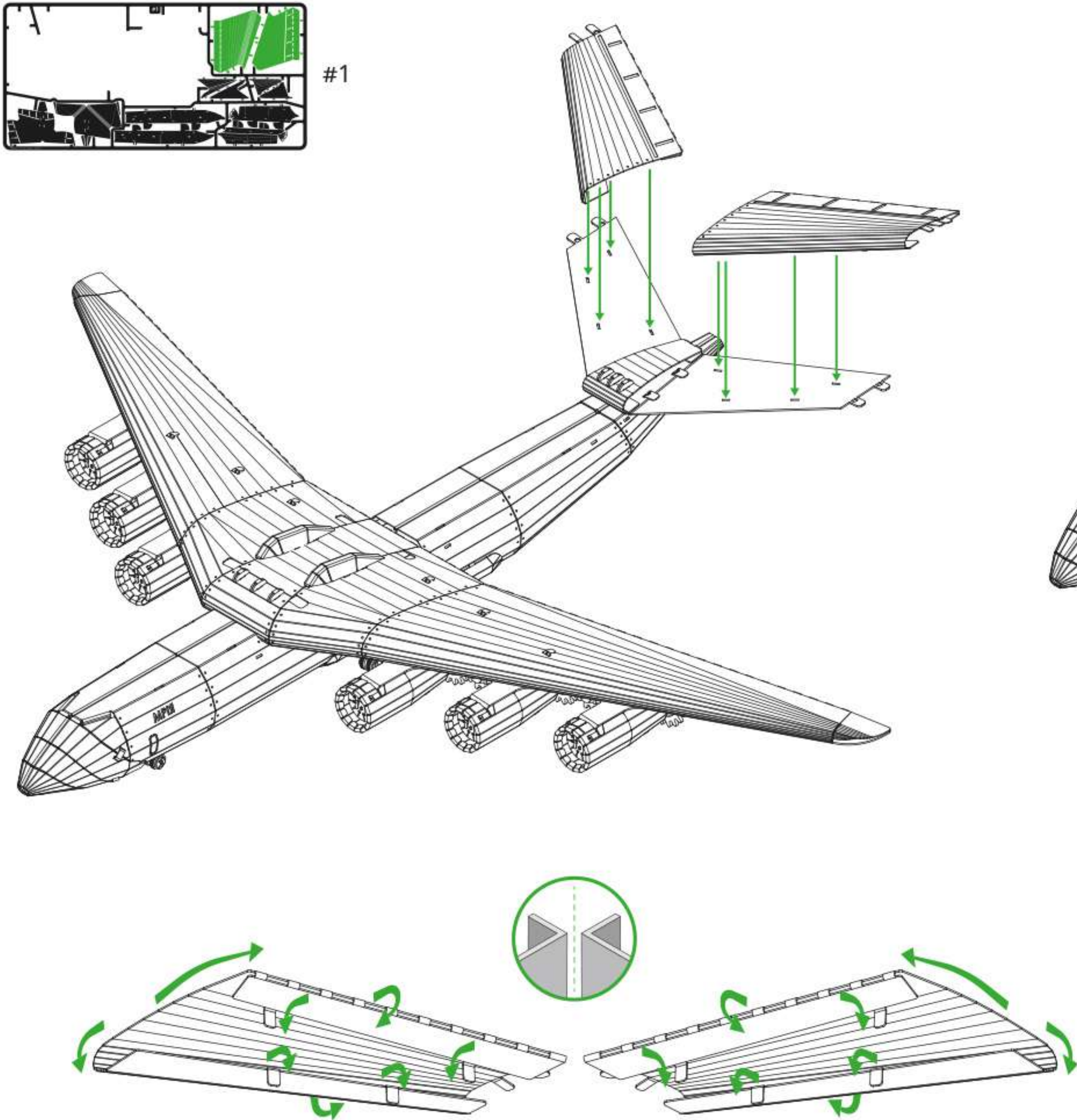

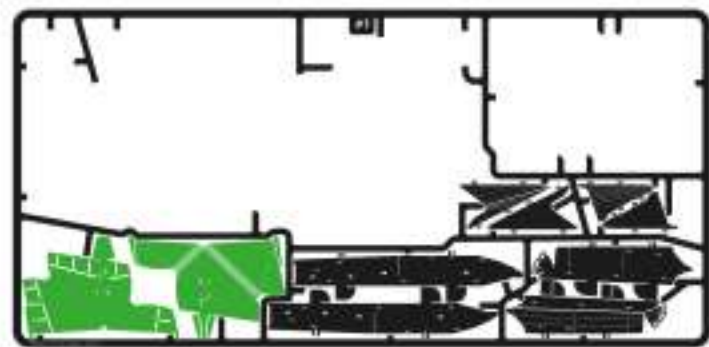

#1

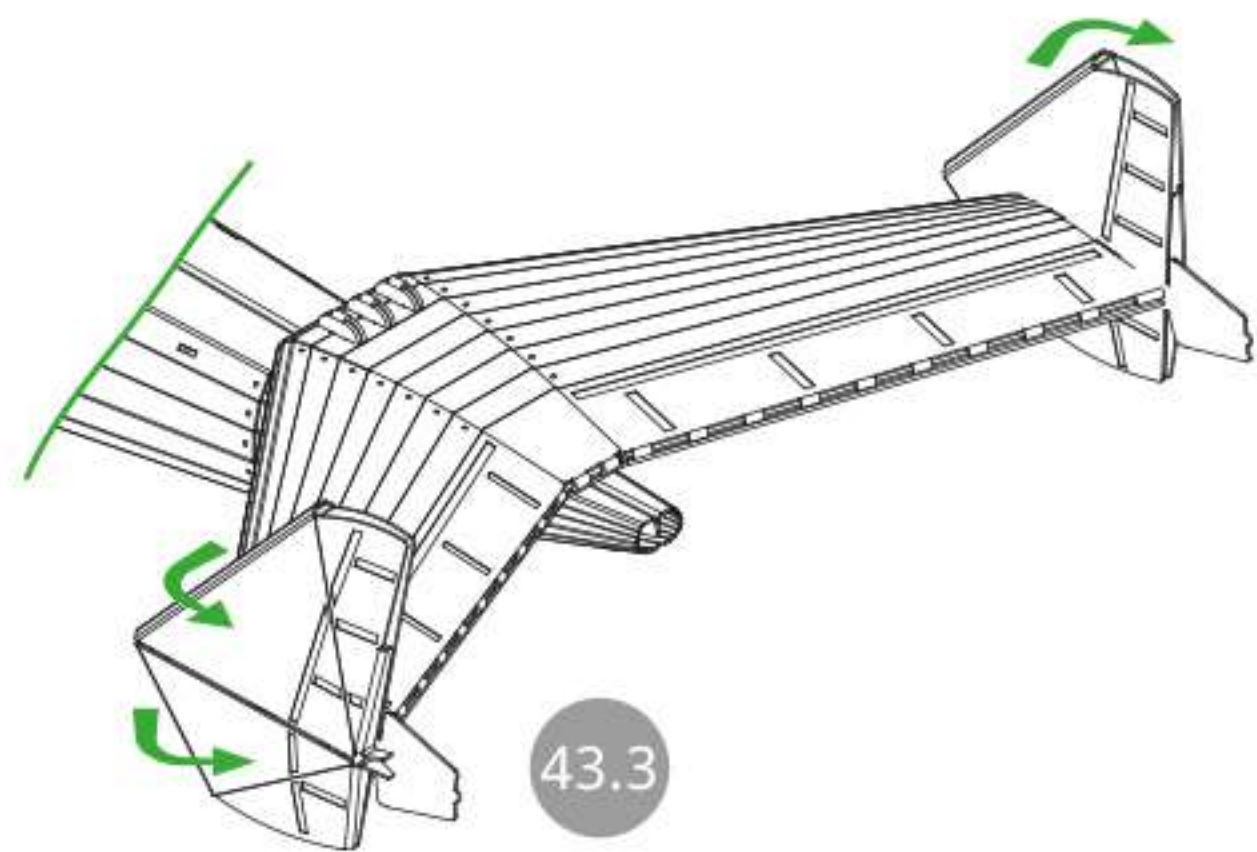
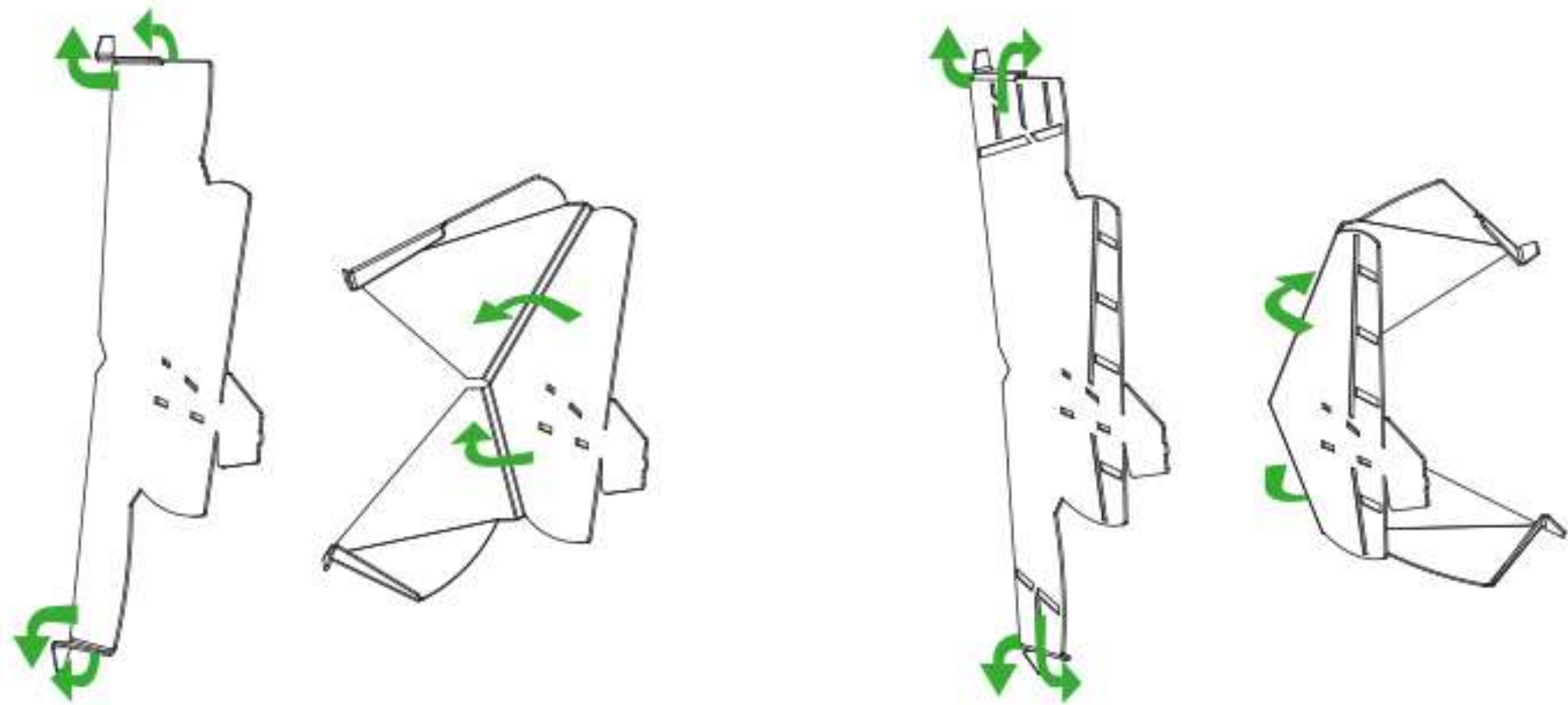

43.3

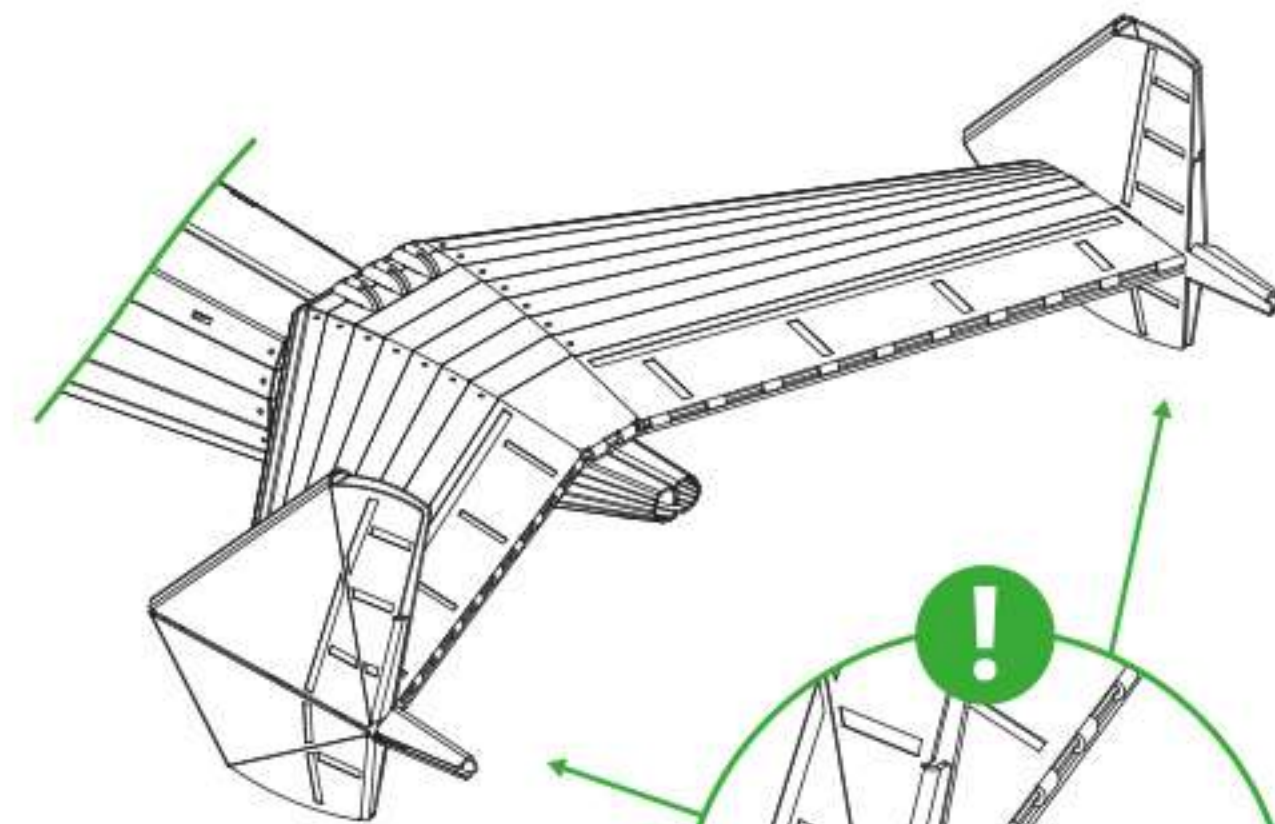

43.4

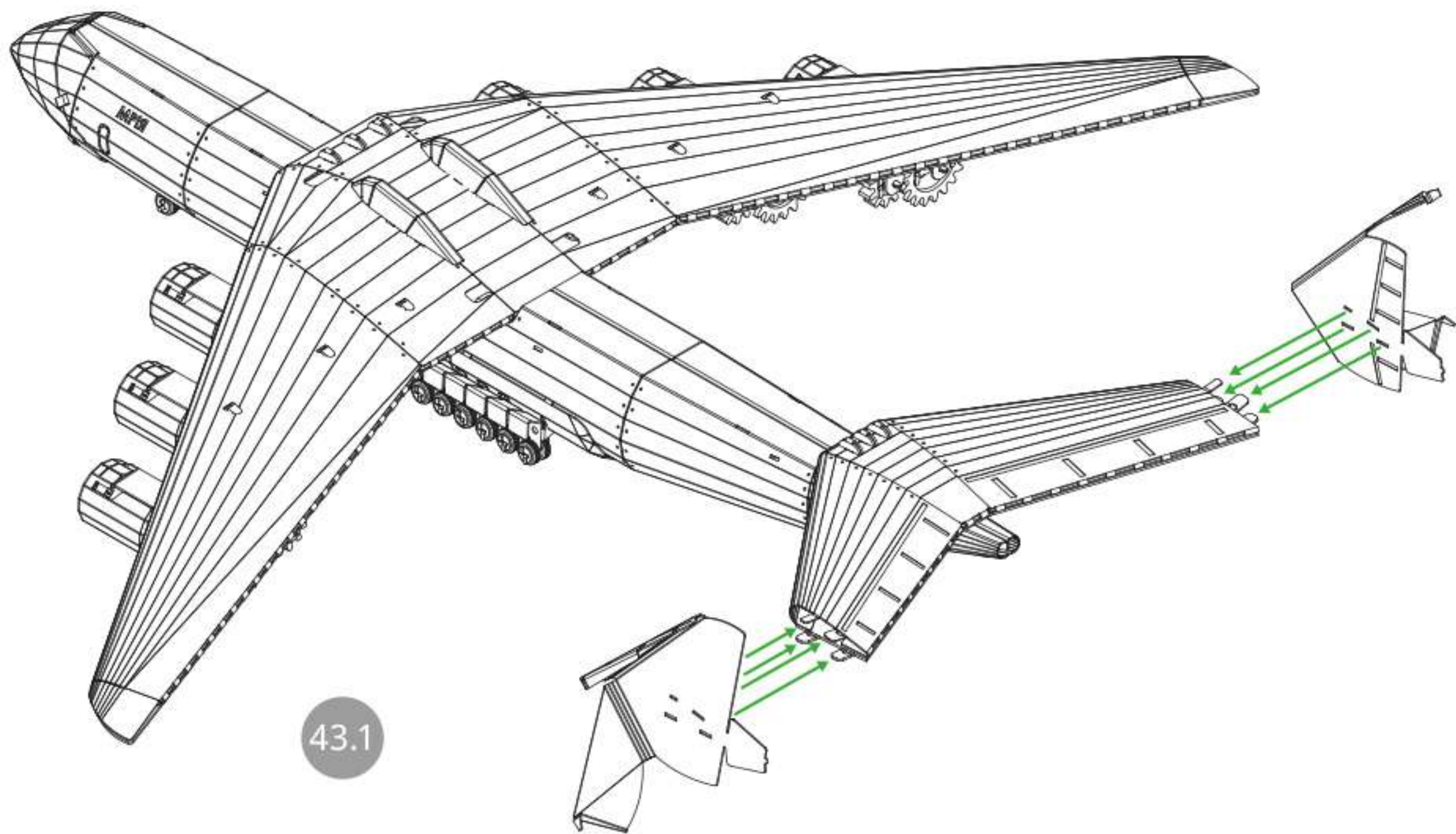

43.1

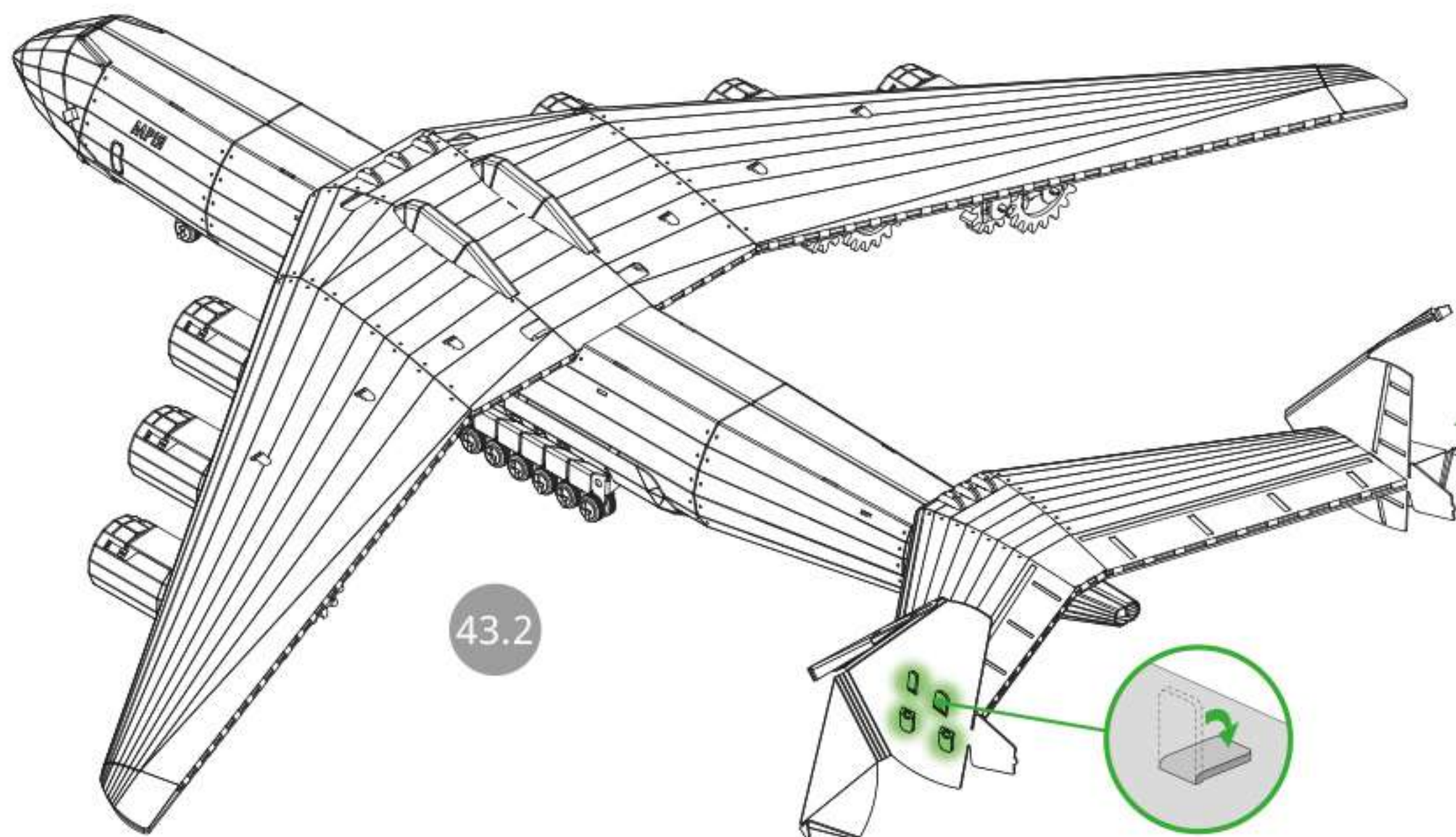

43.2



#1

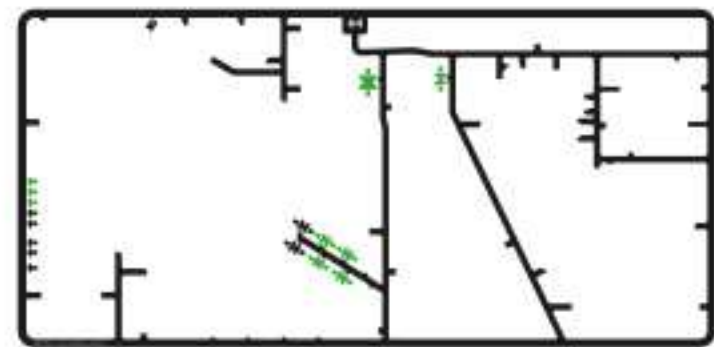

#4



x4

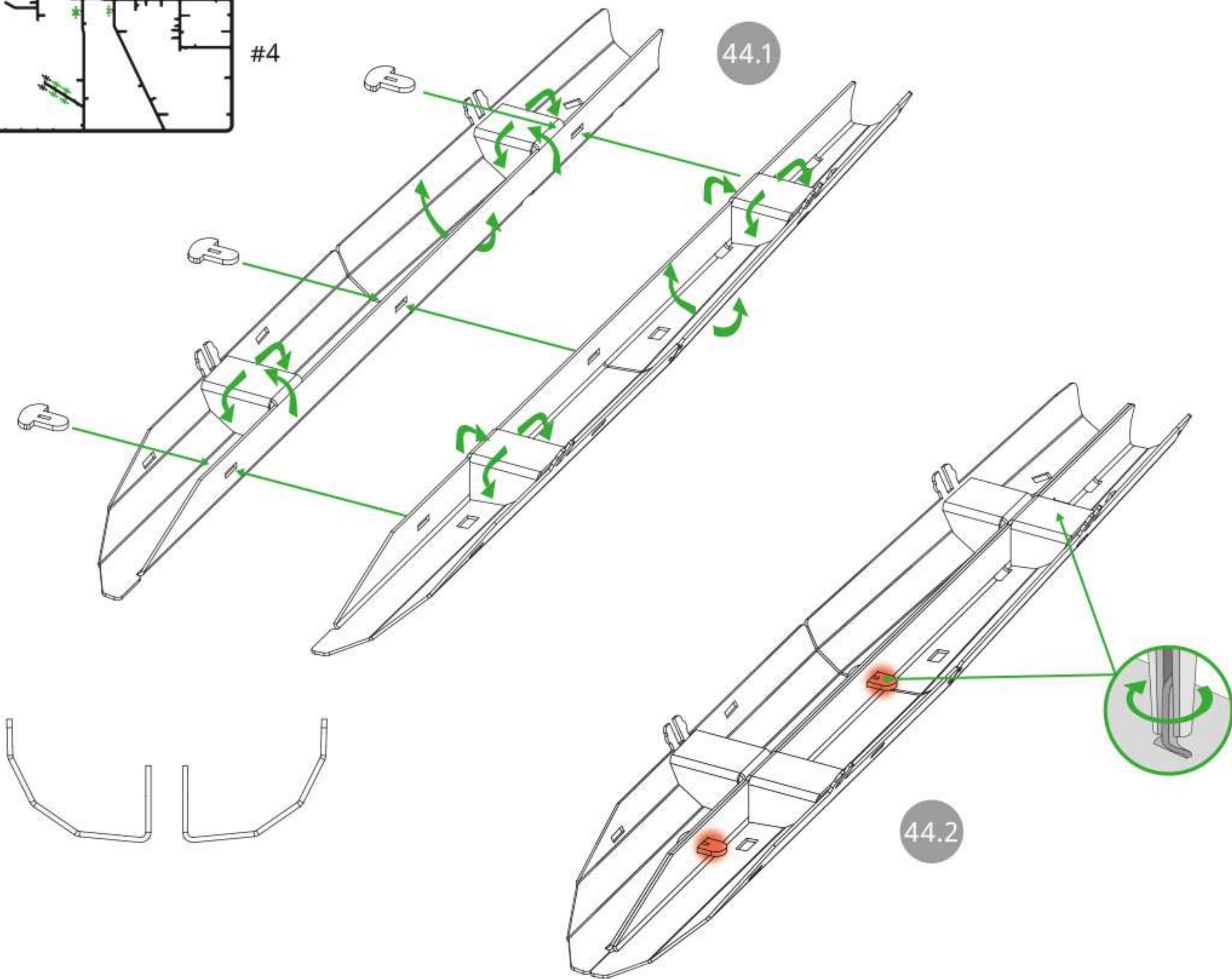

44.1

44.2

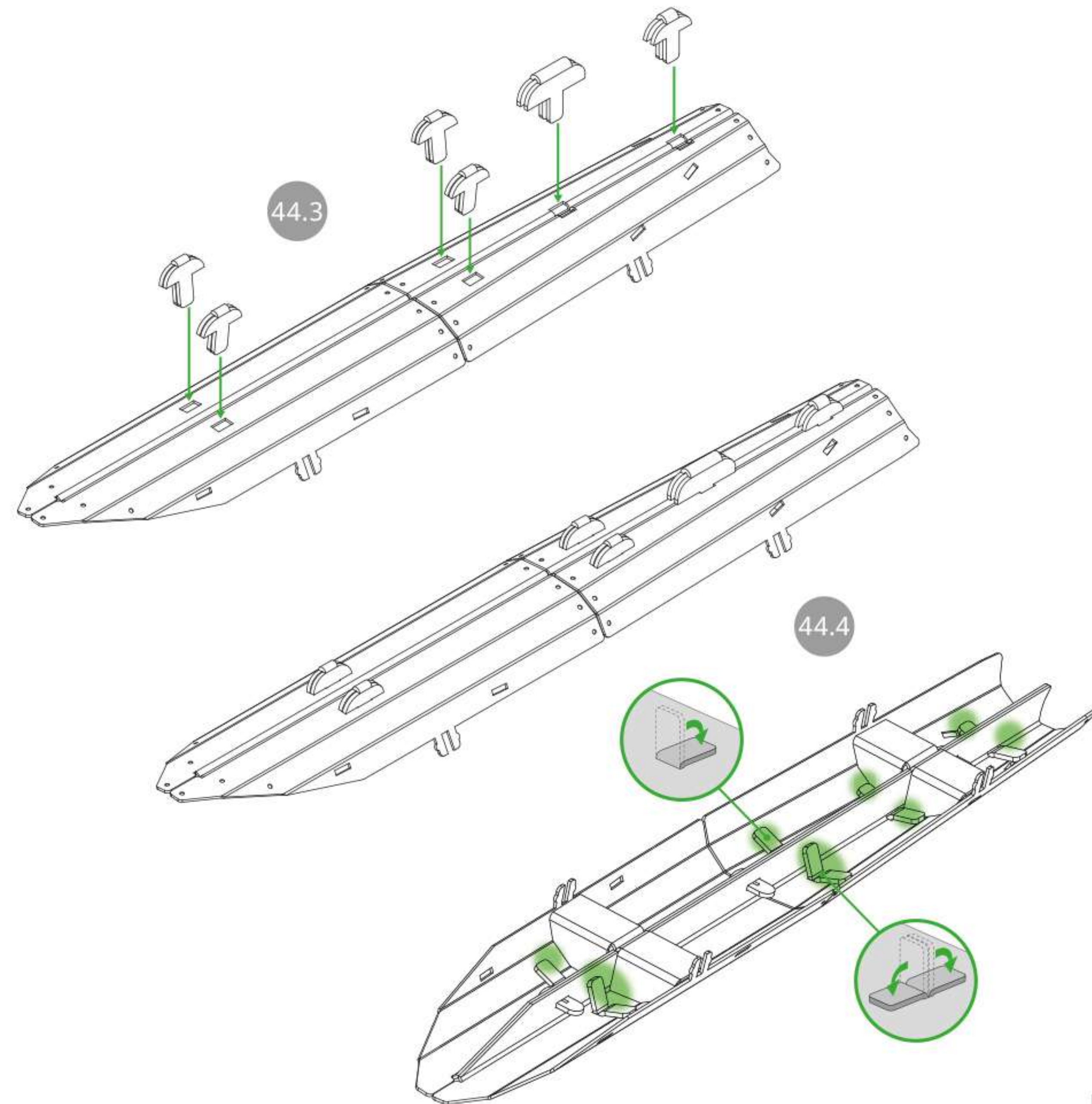

44.3

44.4



This step uses self-locking lugs that do not require additional fixation. For more reliable fastening, it is recommended to slightly open the fasteners before installation.

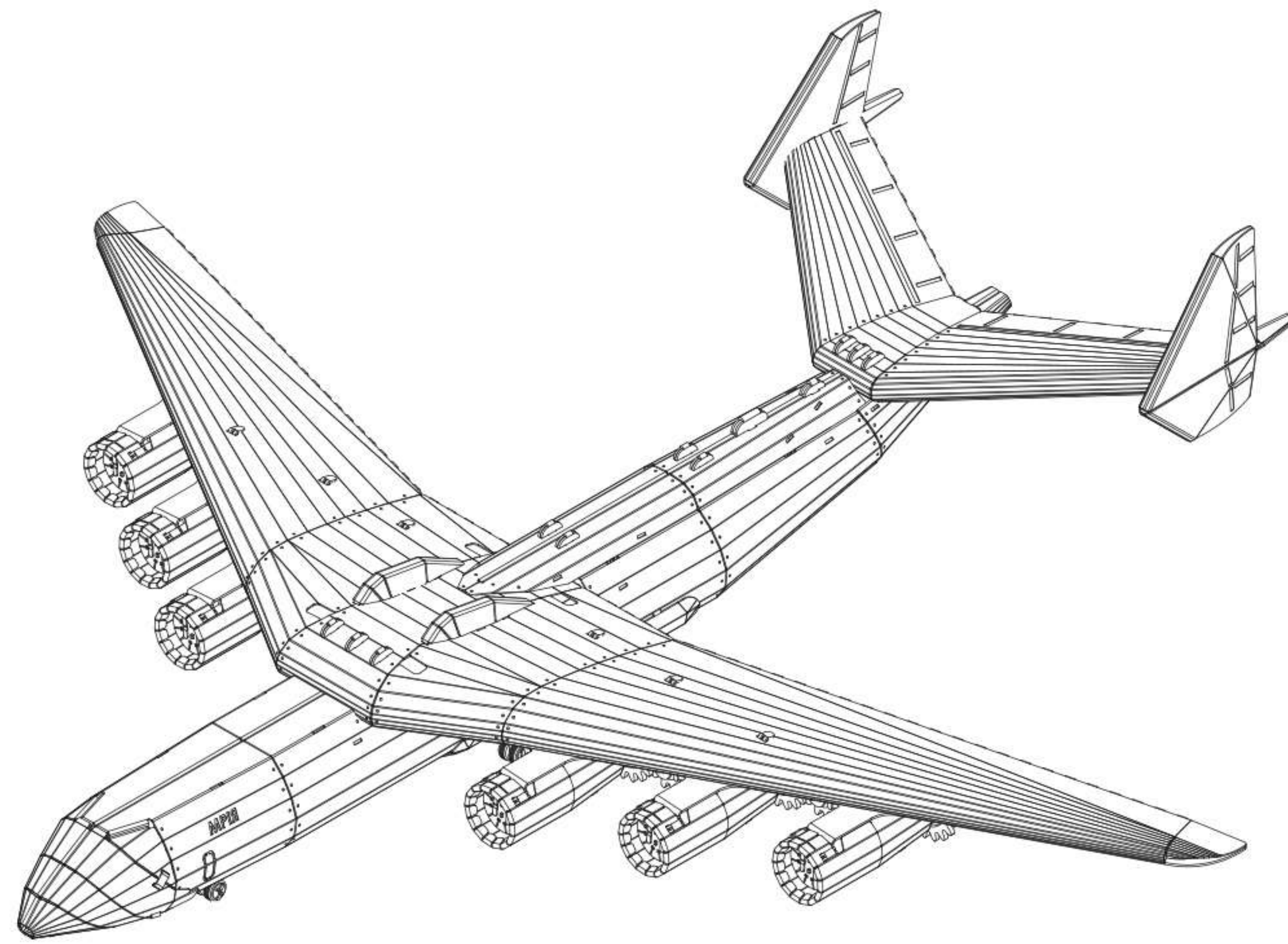
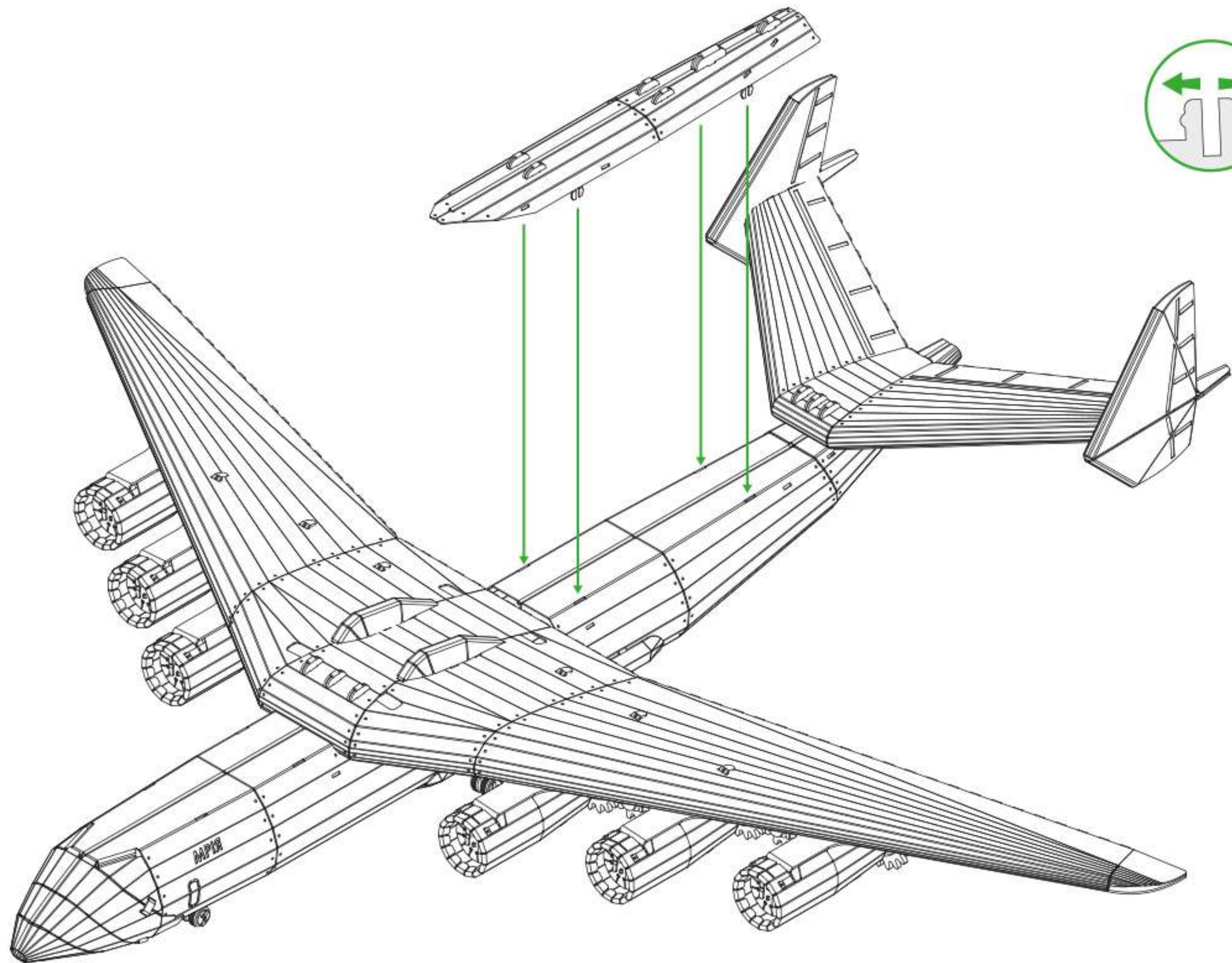



#1

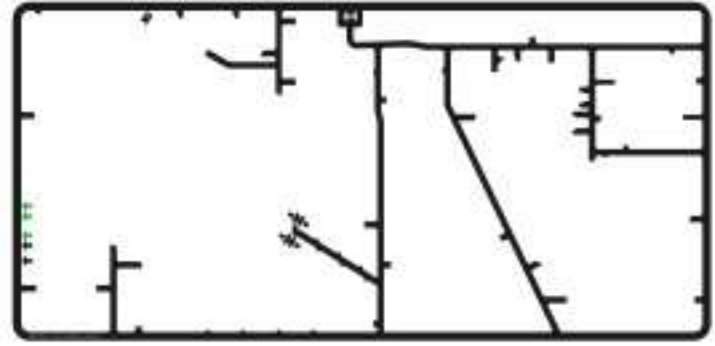

#4

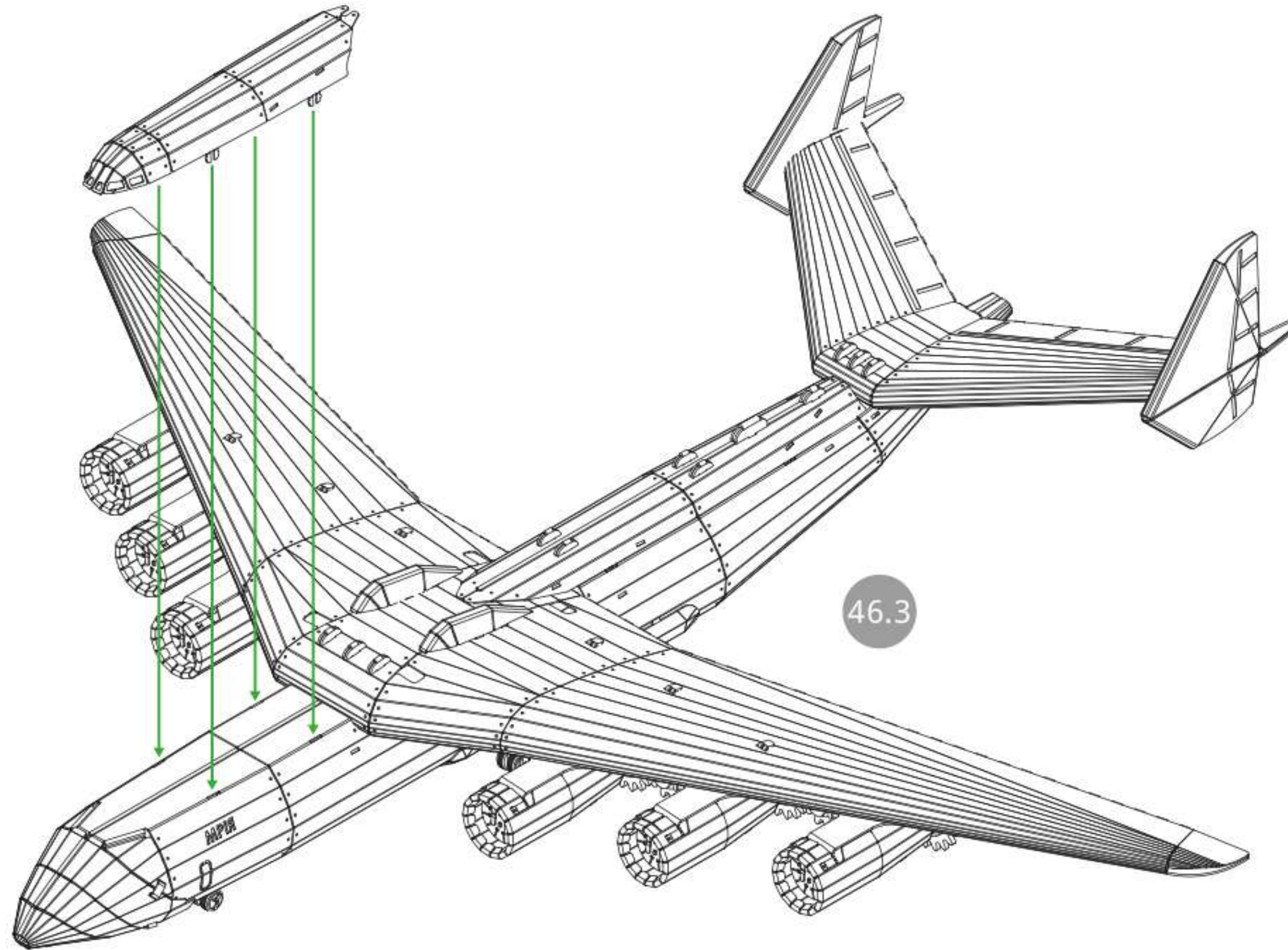

46.3



This step uses self-locking lugs that do not require additional fixation. For more reliable fastening, it is recommended to slightly open the fasteners before installation.

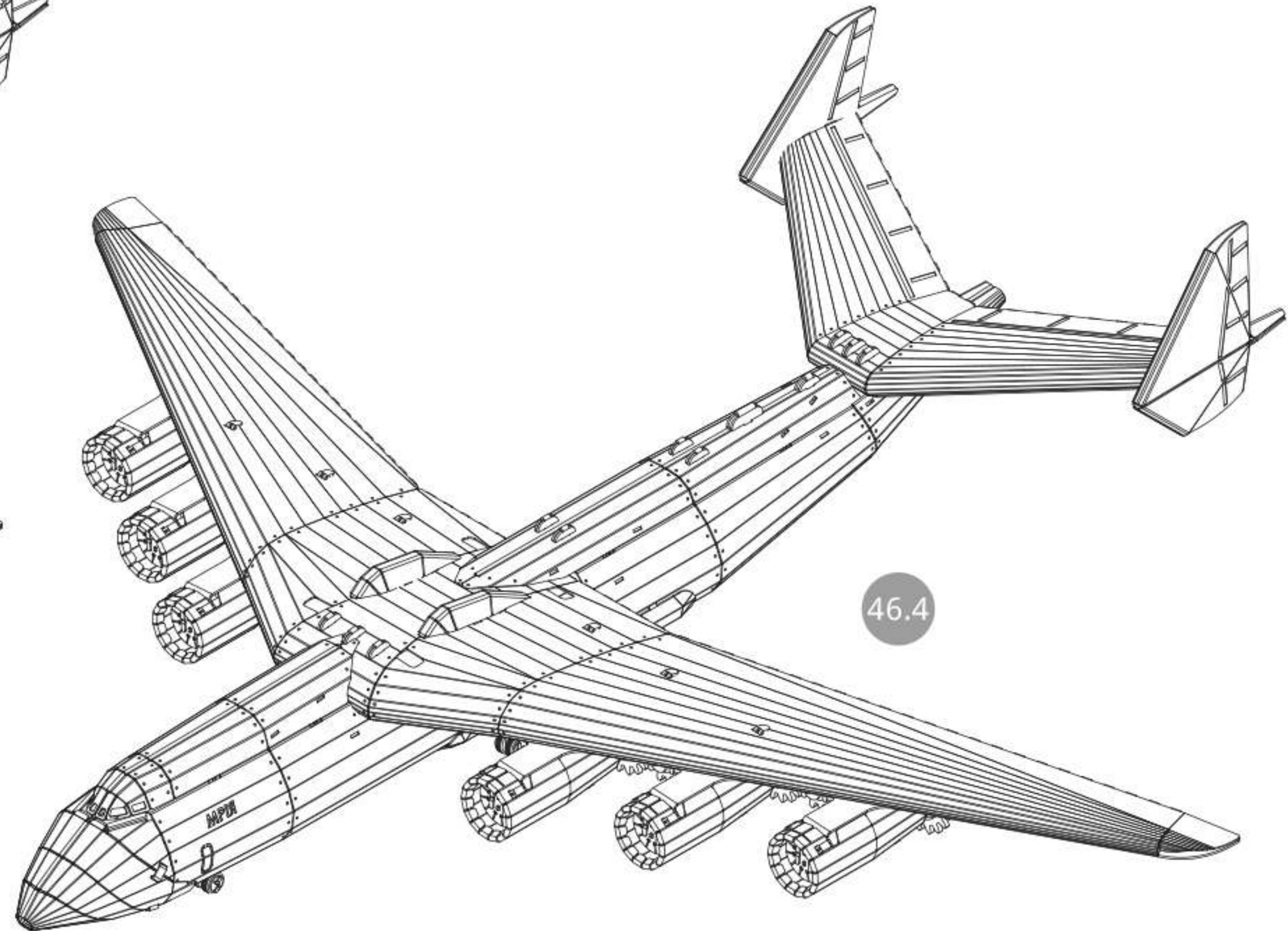

46.4

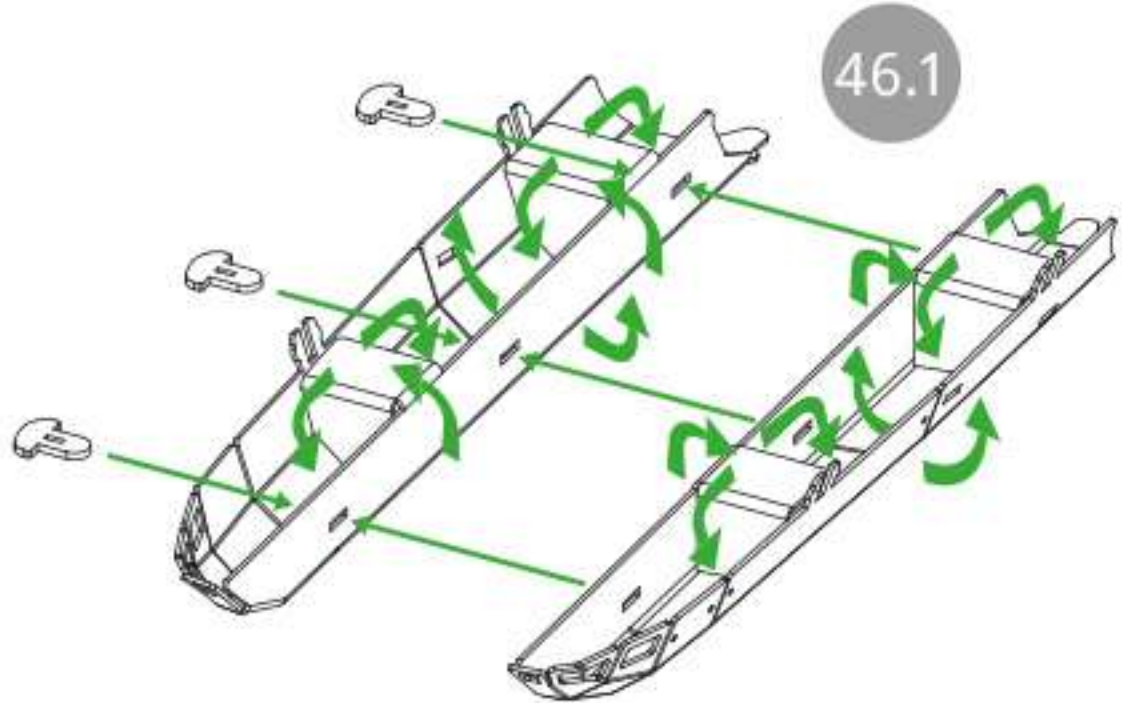
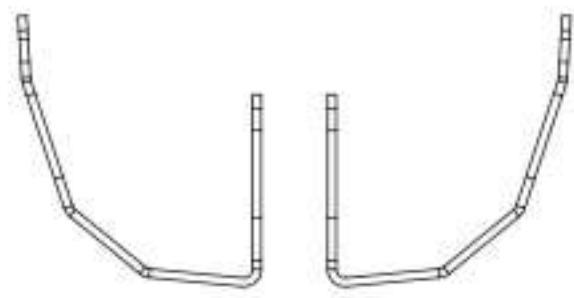

46.1

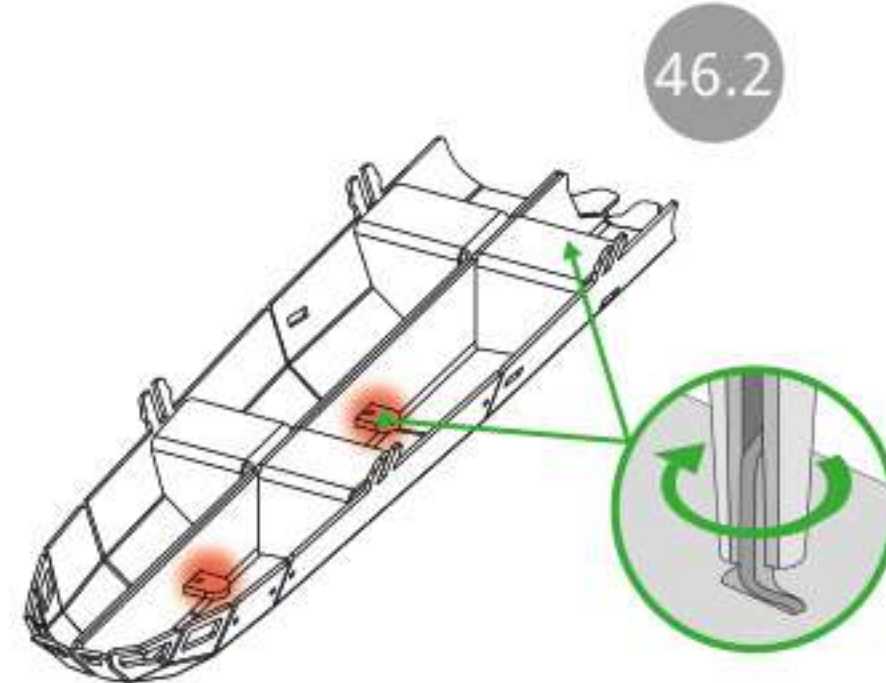

46.2



#3

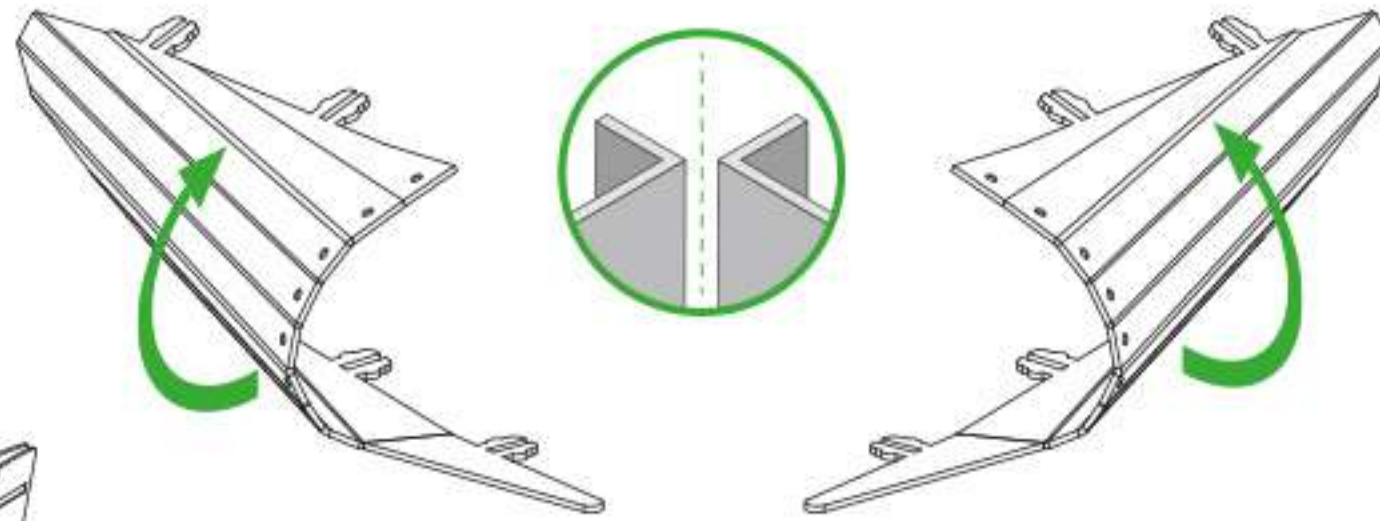

This step uses self-locking lugs that do not require additional fixation. For more reliable fastening, it is recommended to slightly open the fasteners before installation.

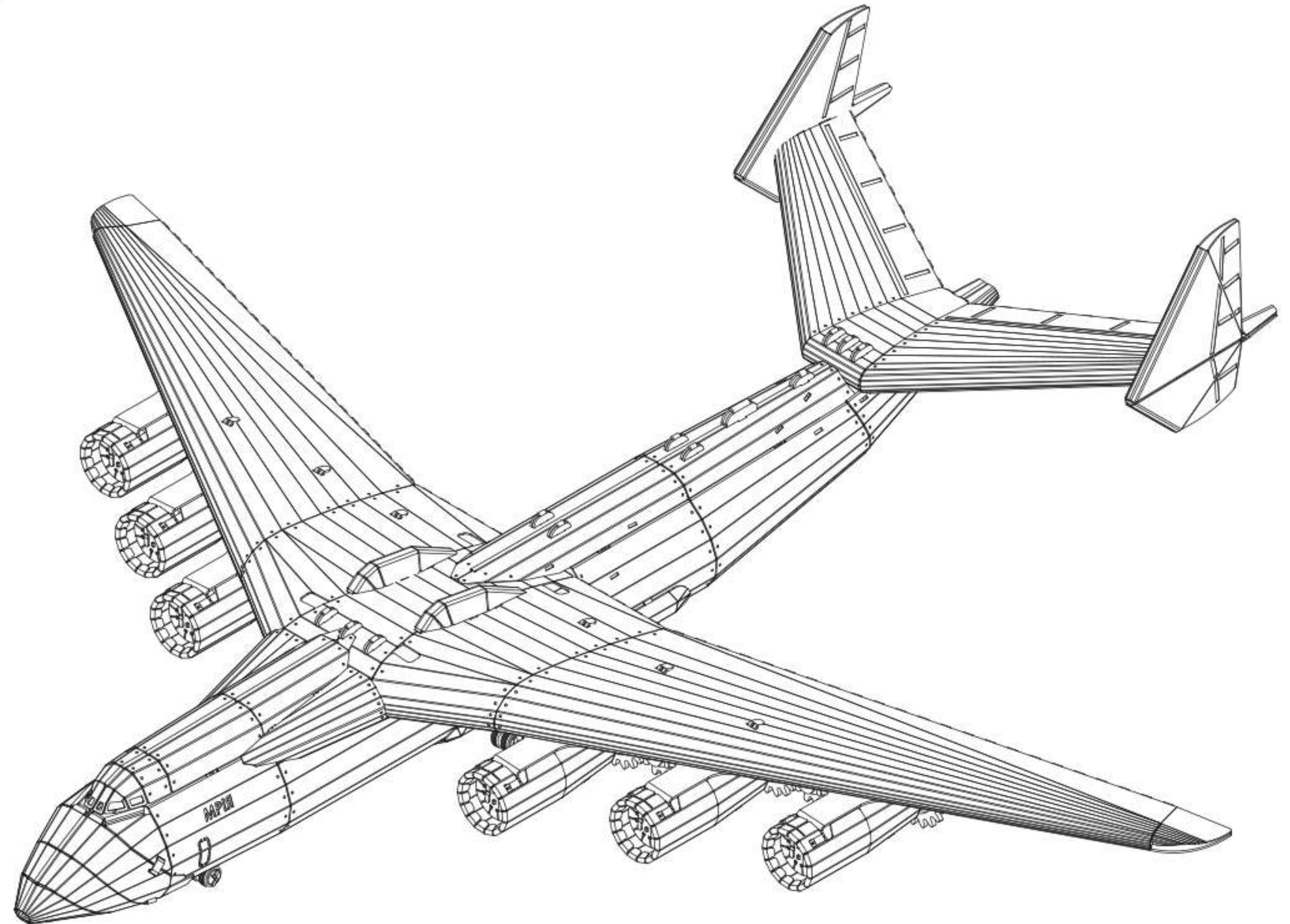
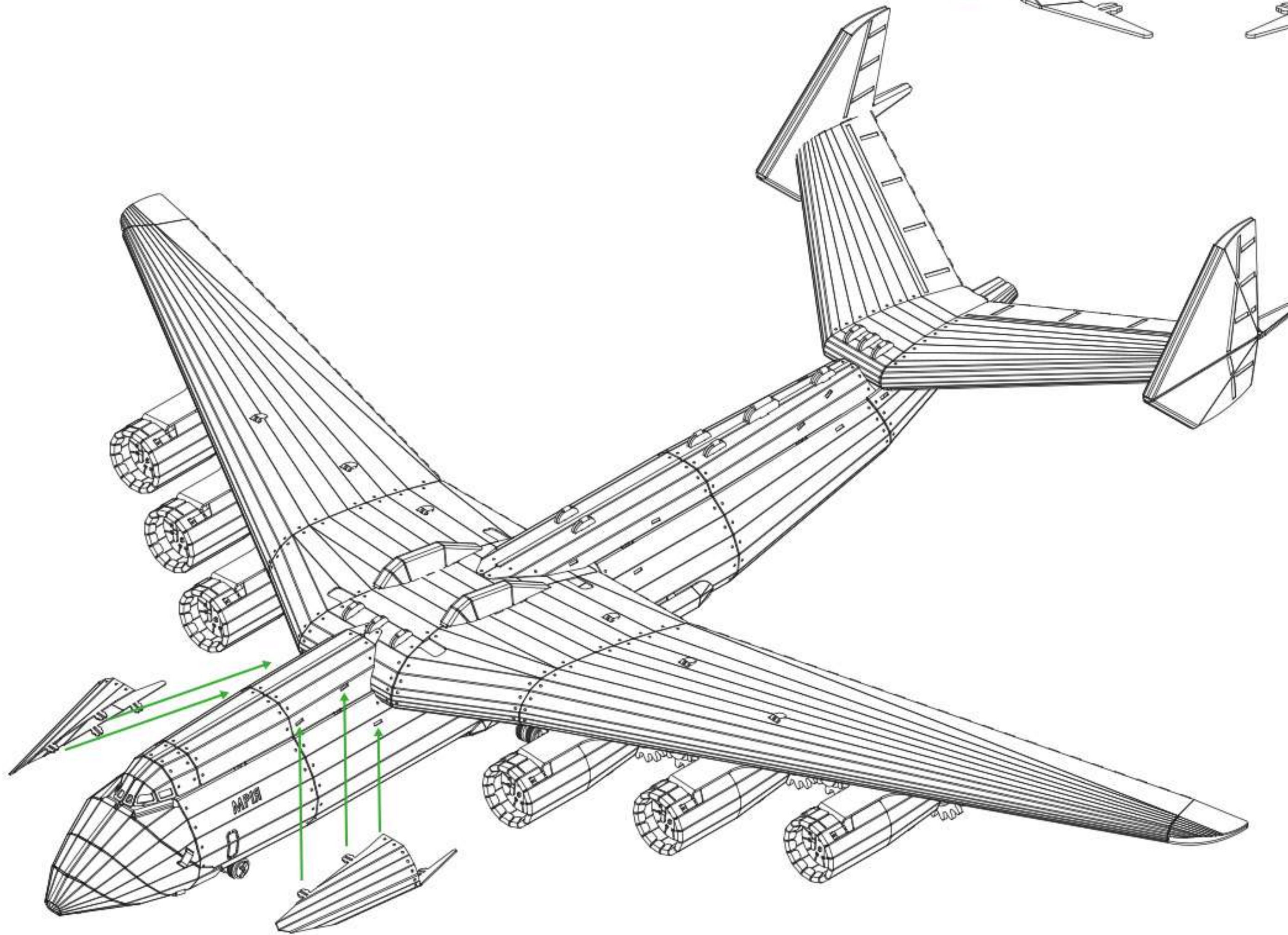

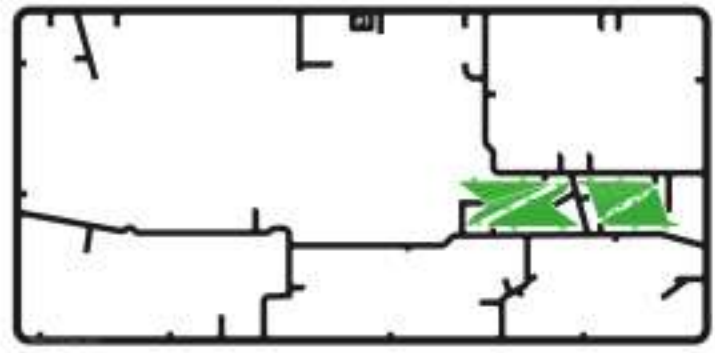

#1

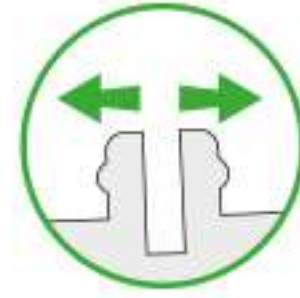
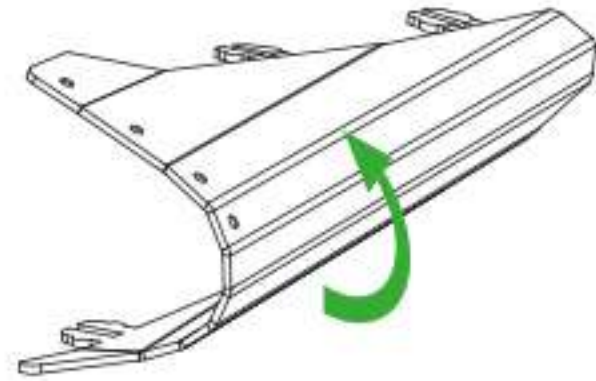
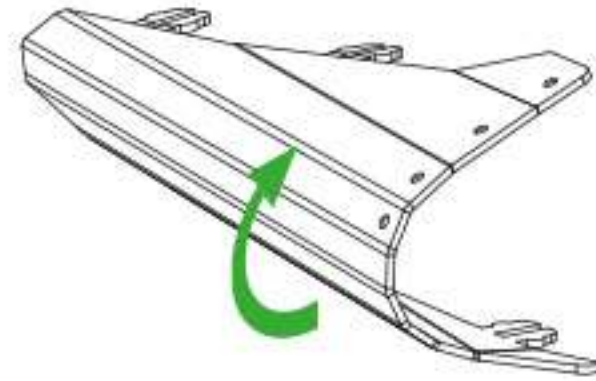
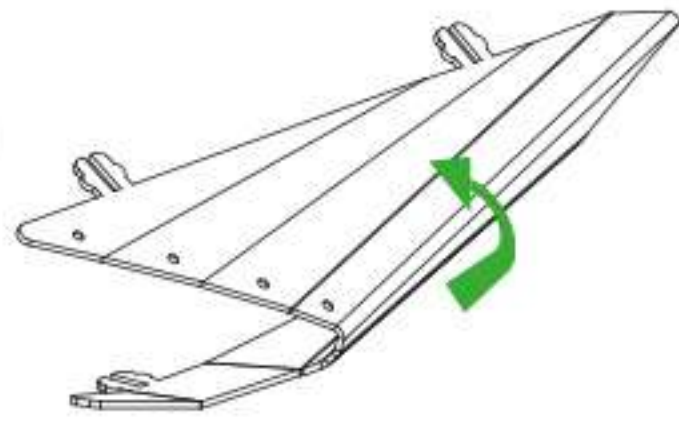
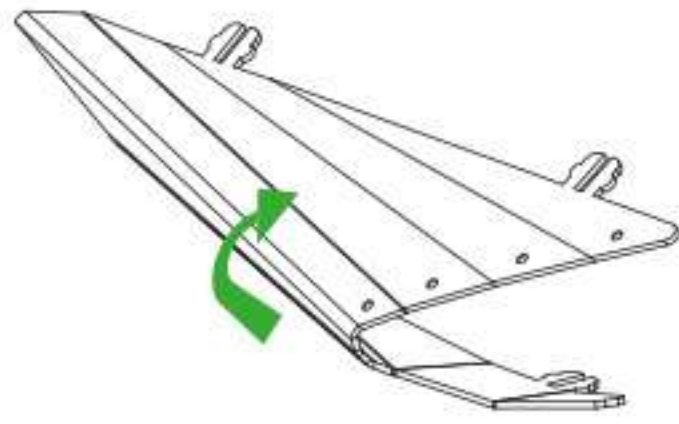

This step uses self-locking lugs that do not require additional fixation. For more reliable fastening, it is recommended to slightly open the fasteners before installation.

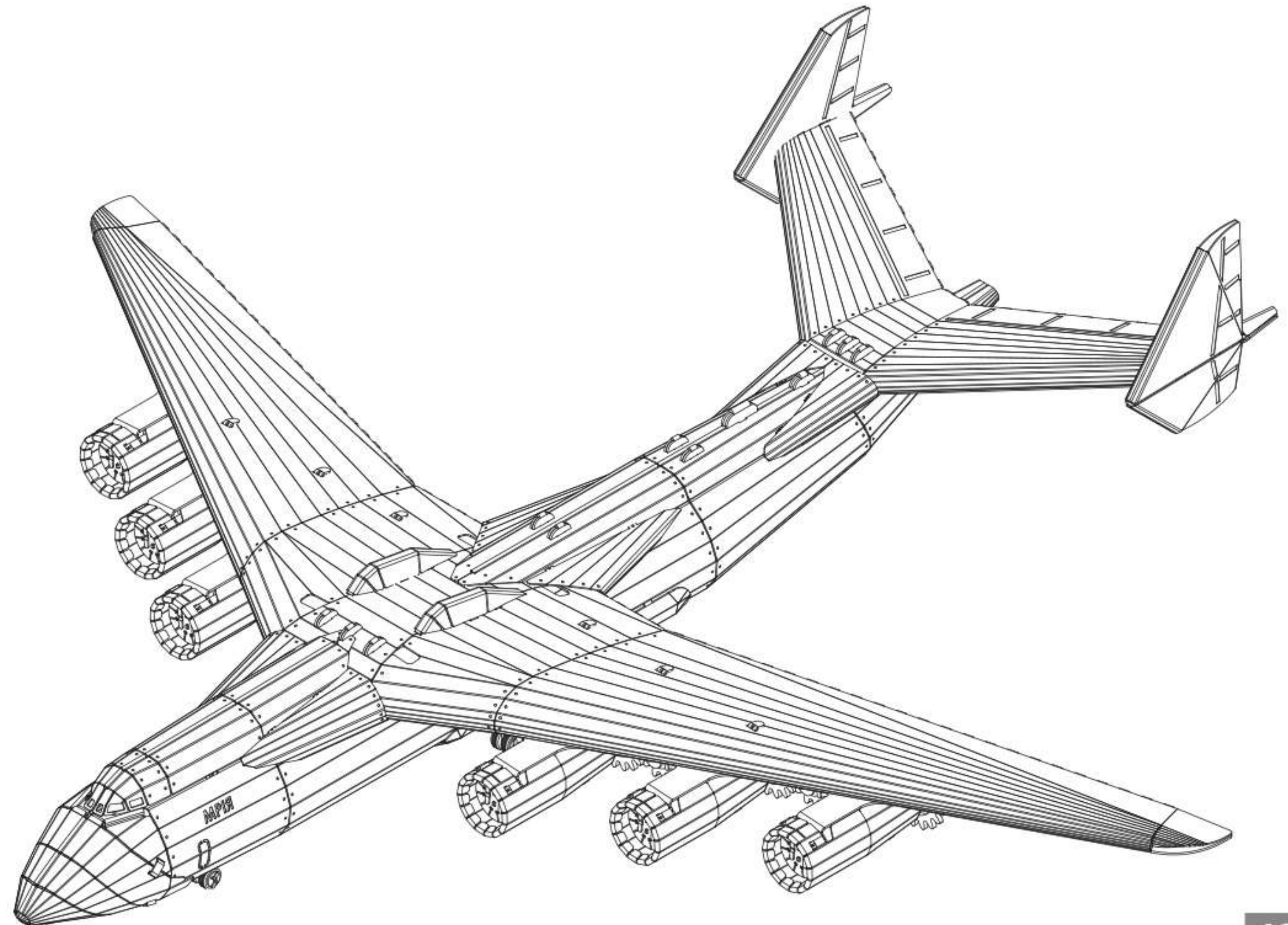
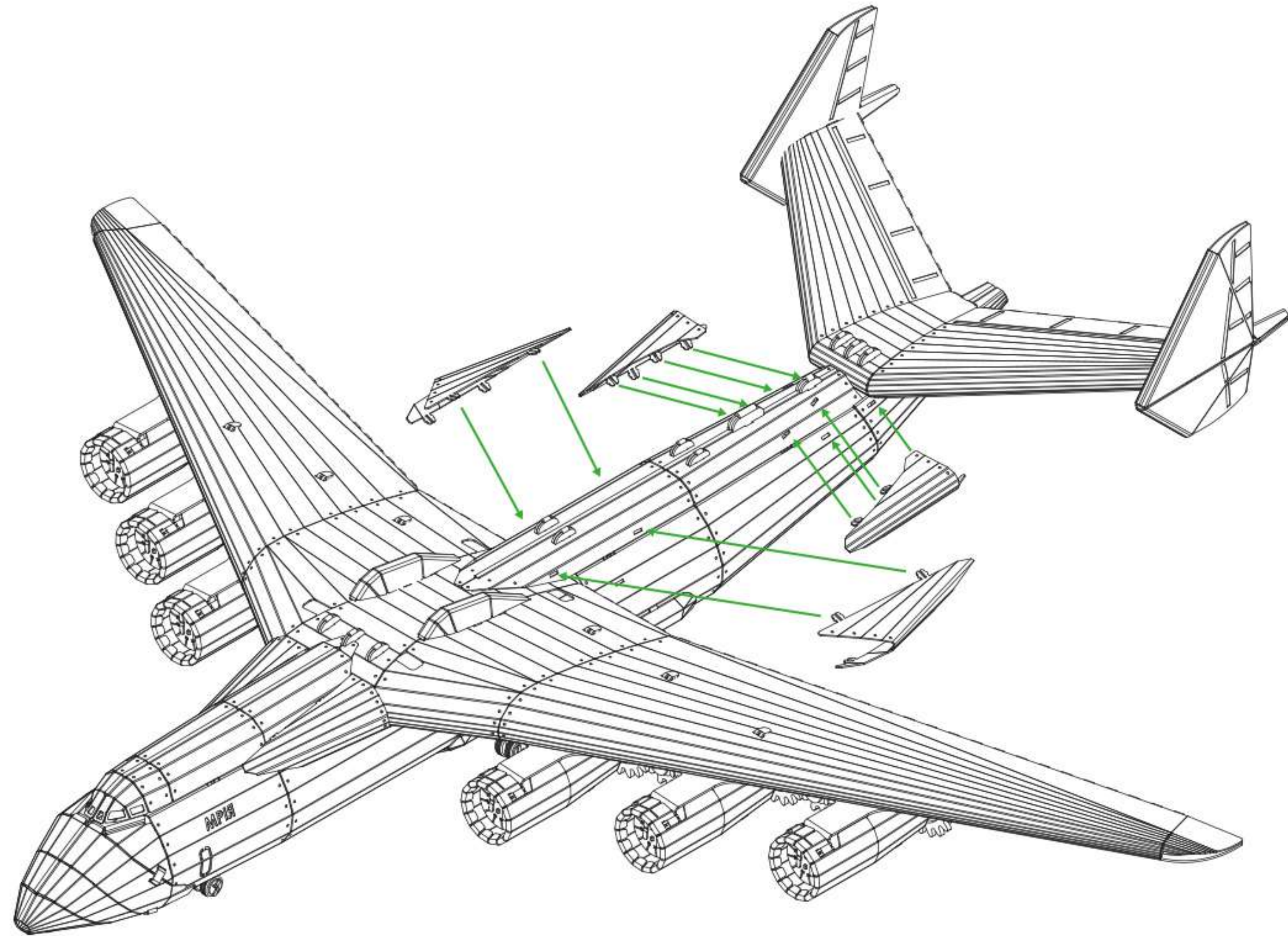

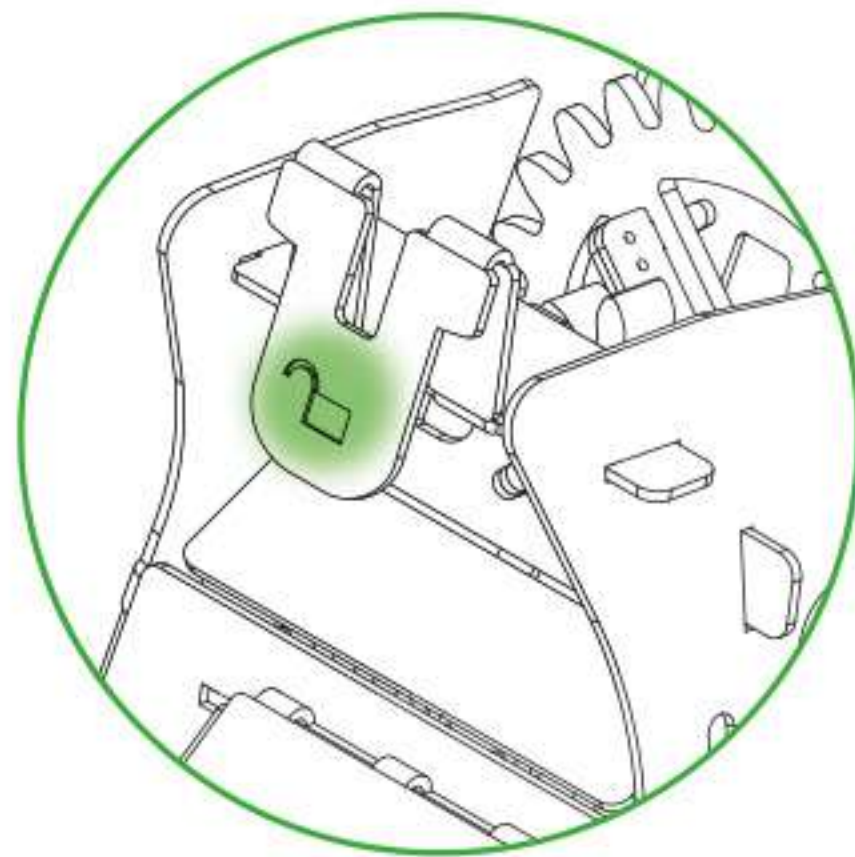
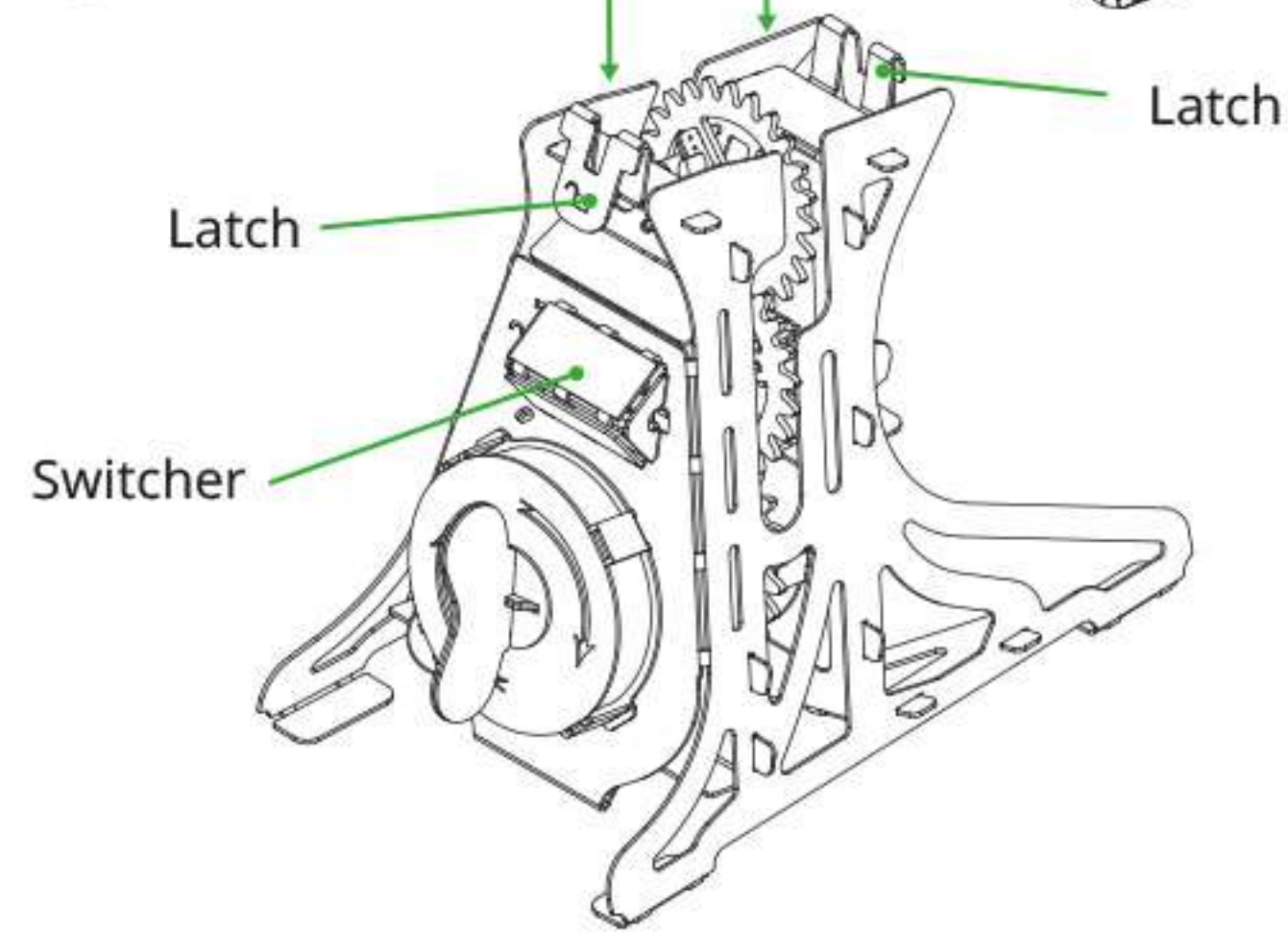
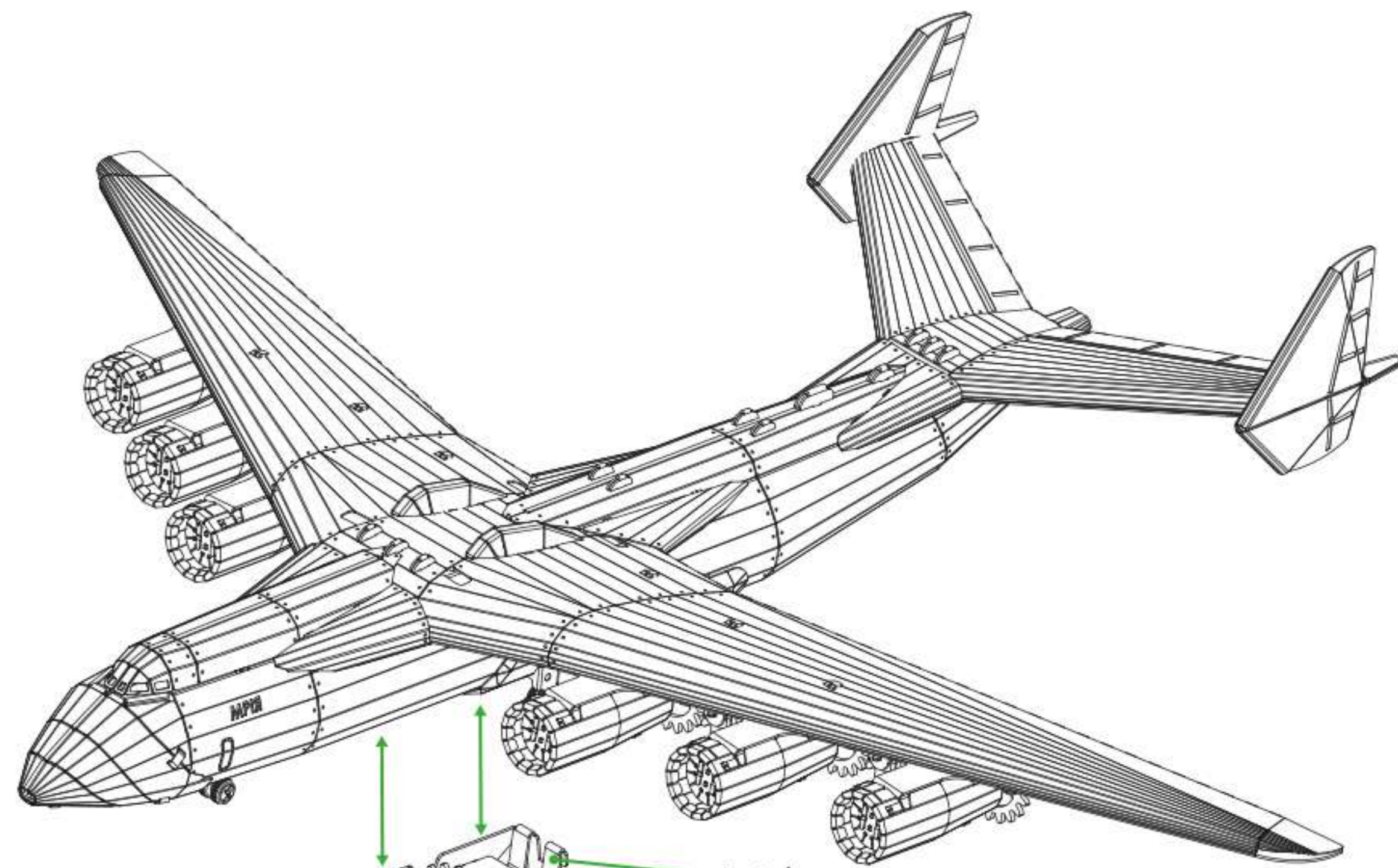

To remove the aircraft from the stand, press the latches on both sides.

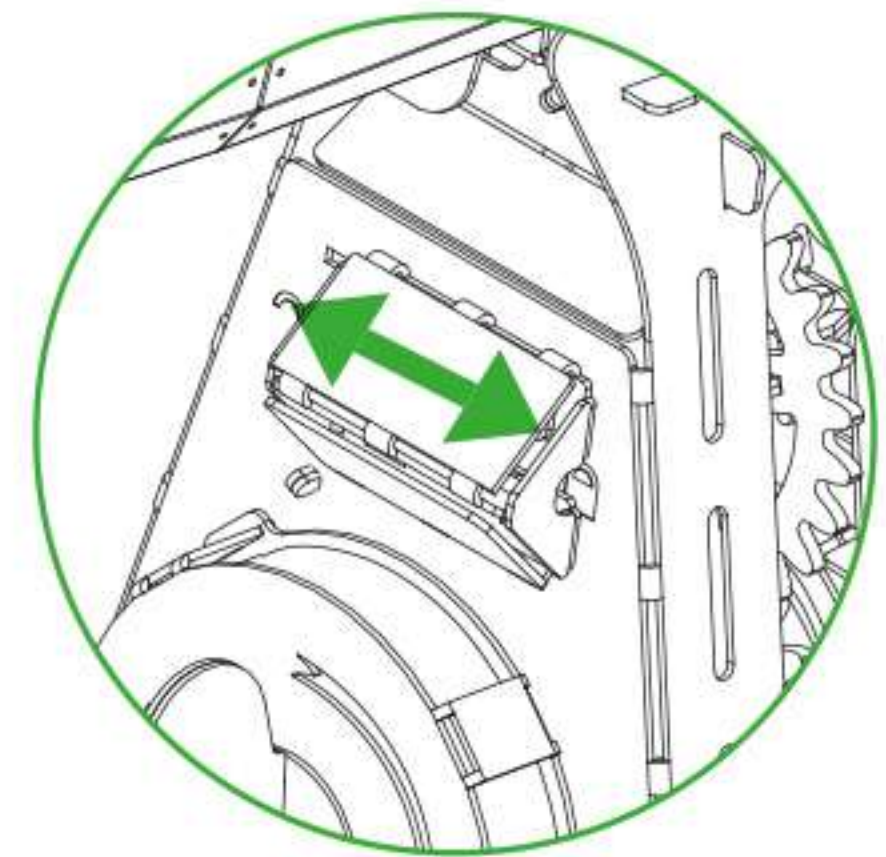
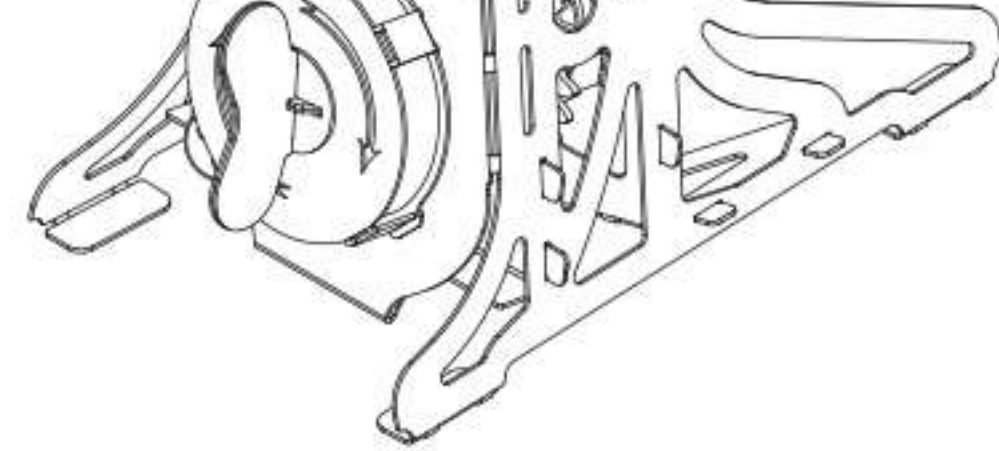
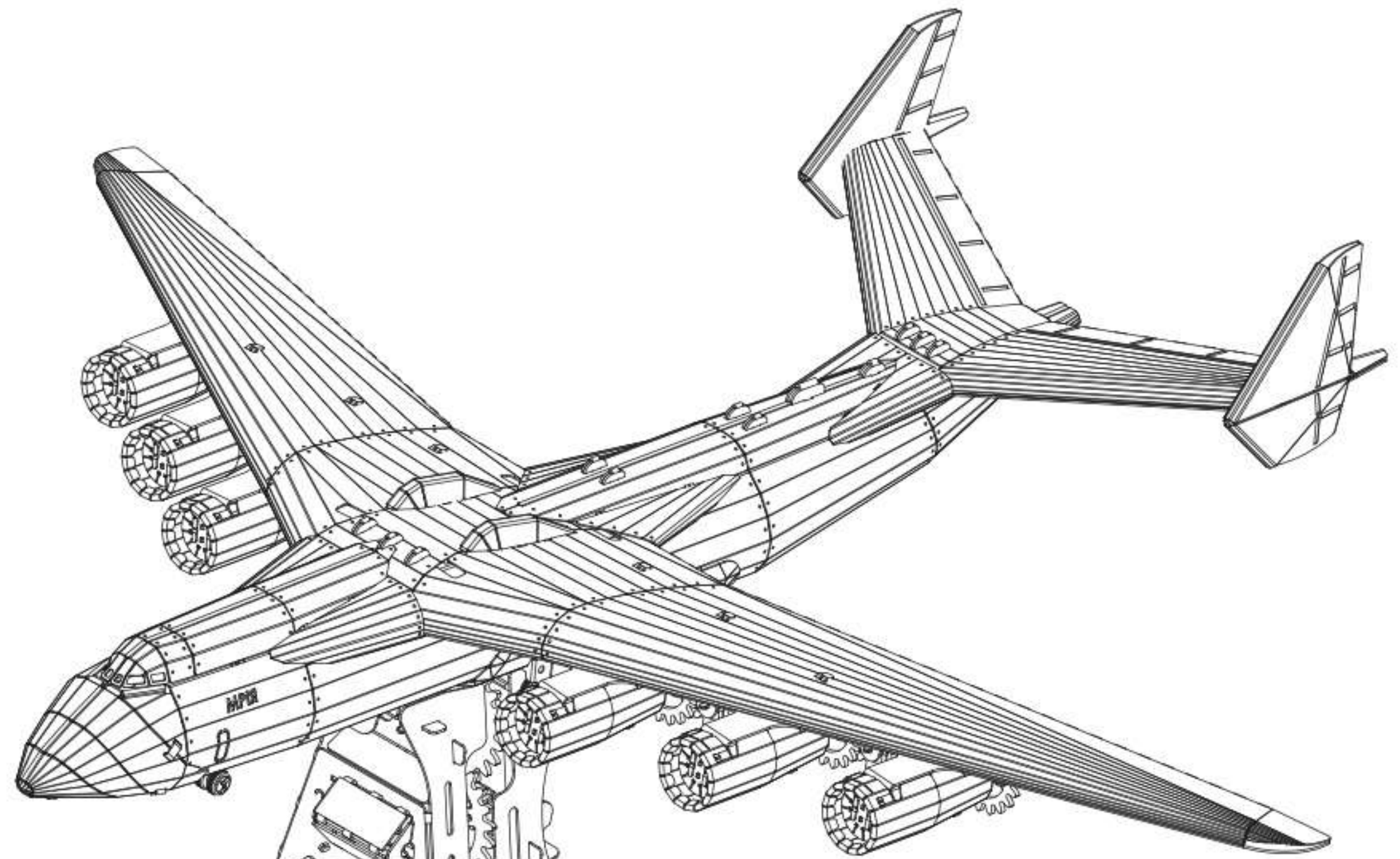

Before start the plane, move the switch to the right, wind the mechanism clockwise, then, to start, move the switch to the left.

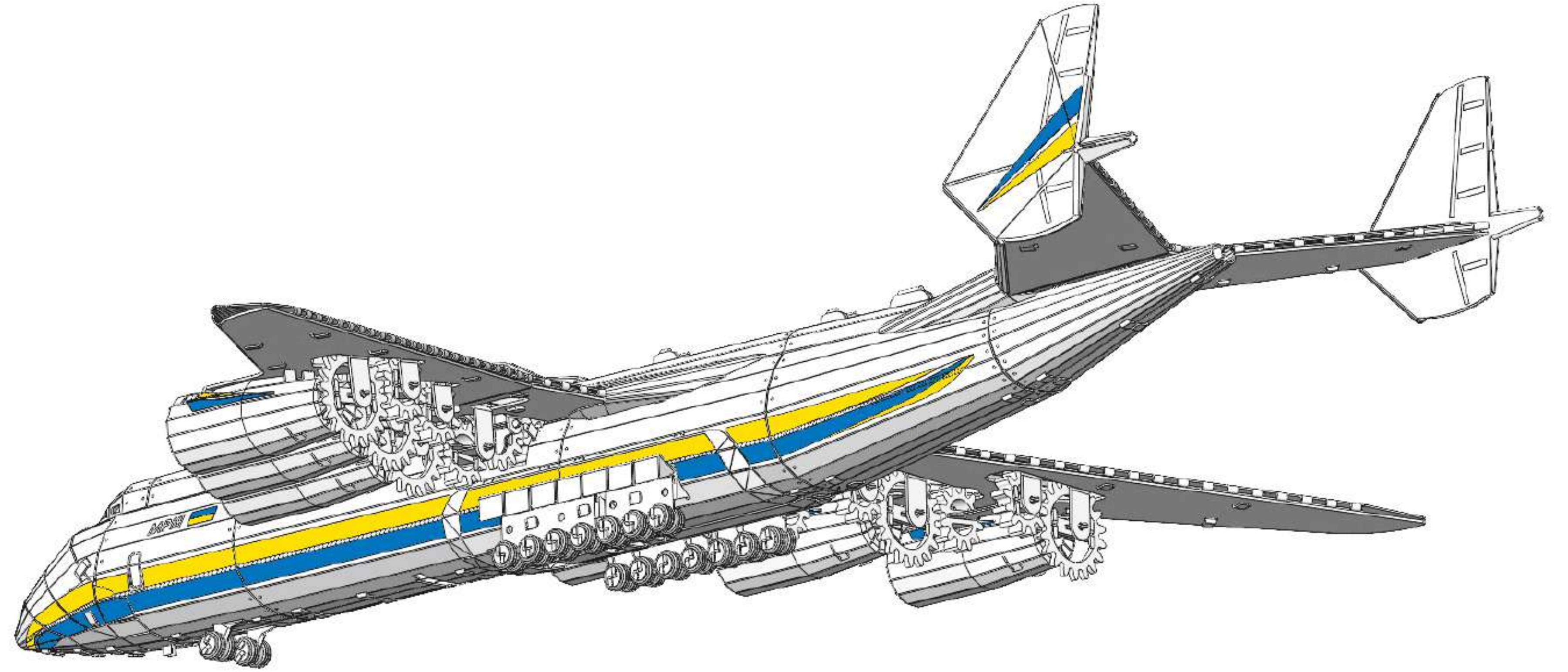
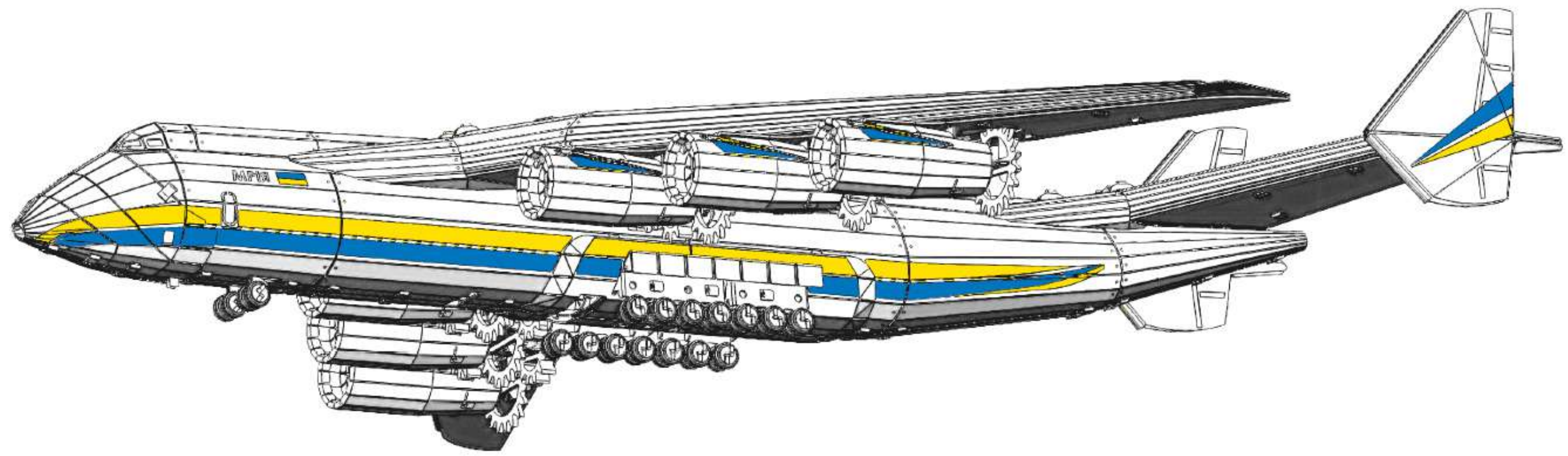



Model name:

UKRAINIAN DREAM

Back in 1988, Ukrainian engineers and aircraft builders created a sensation – the world's largest transport aircraft AN-225. It was called Mriya, translated from Ukrainian – a Dream. This aircraft was the flagship of the world aviation fleet it was designed to carry twice as much as a Boeing 747 freighter. With an overall size that stretched as far as a football field from nose to tail and wingtip to wingtip, and a maximum take-off weight of up to 1.32 million pounds (about 598 tonnes), it dwarfed the 747 in size and lifting capability. Its takeoffs and landings were an attraction for aviation lovers and people from different countries came to see them. At the end of February in 2022, during the Russian attack, the Mriya was destroyed...



Designed in Ukraine

Made in China

Product number: SKU001

Product material: Stainless steel

Number of metal sheets: 5 pcs

Finish product size: L12.09" × W12.6" × H4.88" (L30,7m × W32cm × H12,4cm)

⚠ WARNING!

The product contains small and/or sharp parts. Not suitable for children under 3 years of age. Cut/remove the band that keeps the spring in place ONLY WITHIN the spring chamber/container. DO NOT cut the restraining band outside the assembled spring chamber, as the spring will unwind with force.

In order to avoid possible injury from sharp edges, please carefully discard the metal sheet after parts have been removed. This product is not a toy. Keep out of reach of children.

Conforms to CPSIA and CE standards. The product complies with the requirements of EN 71-1,2,3; ASTM F963, REACH, AS/NZS 8124, GB 6675



Difficulty level

No expiration date

MODEL
BUILDING
KIT

@hobbadd.cn

霍布德



Collect the Best

Includes: steel sheets, gears, power spring, chassis wheels, stickers, pliers, file, gloves, polishing cloth, user's guide, certificate, stamp.

ALL RIGHTS RESERVED
© Metal-Time Inc., USA

www.metal-time.com
info@metal-time.com